

**TS502A**

TS-500KEKD06...../5M/3D/3G

Temperature sensors

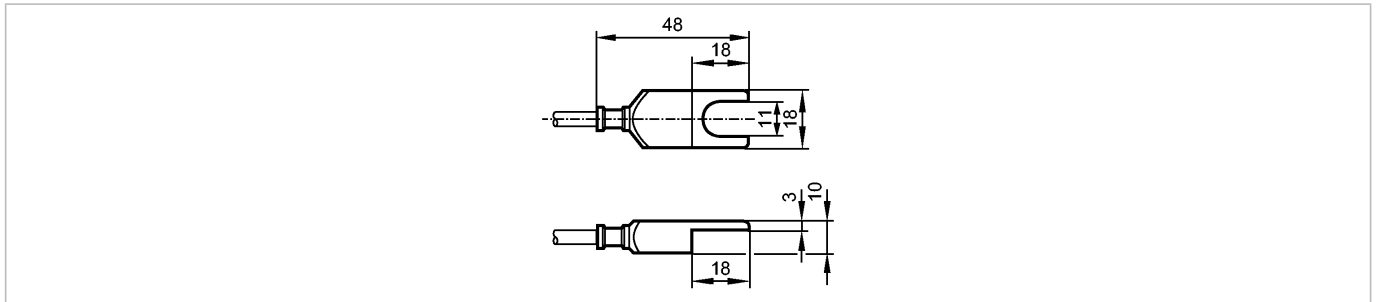

**Product characteristics**

Temperature sensor for connection to evaluation units
Bolt-on sensor 10 x 18 x 48 mm
Cable
Process connection: Bolt-on sensor
ATEX approval
Group II, category 3D/3G
Measuring range: -20...115 °C / -4...239 °F, Measuring range for non-ATEX applications: -20...150 °C / -4...302 °F
Measuring element: 1 x Pt 1000, to DIN EN 60751, class A

**Application**

Application	Contact sensor for solid bodies
-------------	---------------------------------

**Electrical data**

Protection class	III
------------------	-----

**Measuring / setting range**

Measuring range	-20...115 °C	-4...239 °F
Measuring range for non-ATEX applications	-20...150 °C / -4...302 °F	

**Accuracy / deviations**

Accuracy	± (0.15 K + 0.002 x  t )
----------	--------------------------

**Response times**

Dynamic response	T05 / T09 [s]	18 / 42
------------------	---------------	---------

**Environment**

Protection	IP 67
------------	-------

**Tests / approvals**

Marking of the unit	Ex II 3D Ex tc IIIC T135°C Dc X Ex II 3G Ex nA IIC T4 Gc X
---------------------	---

**Mechanical data**

Process connection	Bolt-on sensor
Housing materials	stainless steel 316Ti / 1.4571
Weight [kg]	0.235

**Electrical connection**

Connection	silicone cable / 5 m
------------	----------------------

**Wiring**

## TS502A

TS-500KEKD06...../5M/3D/3G

Temperature sensors

Core colours

RD red

WH white

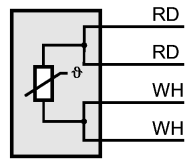

### Remarks

Pack quantity

[piece]

1