



Operating instructions

Absolute encoders RM8x
with SSI interface

UK

706264/02 02/2017

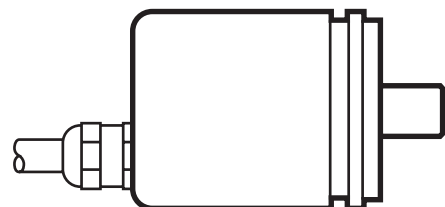

Contents

1 Preliminary note.....	3
1.1 Symbols used	3
2 Safety instructions	3
3 Functions and features	4
4 Installation	4
4.1 Installation solid shaft encoder (synchro flange).....	4
4.2 Installation hollow shaft encoder.....	5
5 Electrical connection.....	5
5.1 Laying the cable.....	5
5.2 Standard wiring.....	6
6 Operation.....	6
6.1 Data signals	6
6.1.2 Triggering of a data word	6
6.1.3 Level of the control inputs	7
7 Maintenance, repair, disposal.....	7

1 Preliminary note

1.1 Symbols used

- An instruction is indicated by "▶".
Example: ▶ Mount the unit as shown.
- A reaction to the action is indicated by ">".
Example: > Yellow LED is lit.



Important note

Non-compliance can result in malfunction or interference.

UK

2 Safety instructions

- Please read the product description prior to set-up of the unit. Ensure that the product is suitable for your application without any restrictions.
- The unit conforms to the relevant regulations and EC directives.
- Improper or non-intended use may lead to malfunctions of the unit or to unwanted effects in your application.
- That is why installation, electrical connection, set-up, operation and maintenance of the unit must only be carried out by qualified personnel authorised by the machine operator.

3 Functions and features

The encoder converts rotary movements into digital numerical values. Each revolution and each angular position of the revolutions is provided as a numerical value.

These values allow angular movements to be measured and positions and number of revolutions to be determined.

- Supply voltage and resolution according to the type label

4 Installation

- ▶ Disconnect power. The drive must not be started during installation.
- ▶ Do not hit the shaft; do not use a file or similar tool on the shaft. Risk of destruction!

Attention: This product corresponds to the standard EN 61000-6-4. The unit may cause radio interference in domestic areas. Where applicable, the user has to take appropriate measures to avoid these.

4.1 Installation solid shaft encoder (synchro flange)

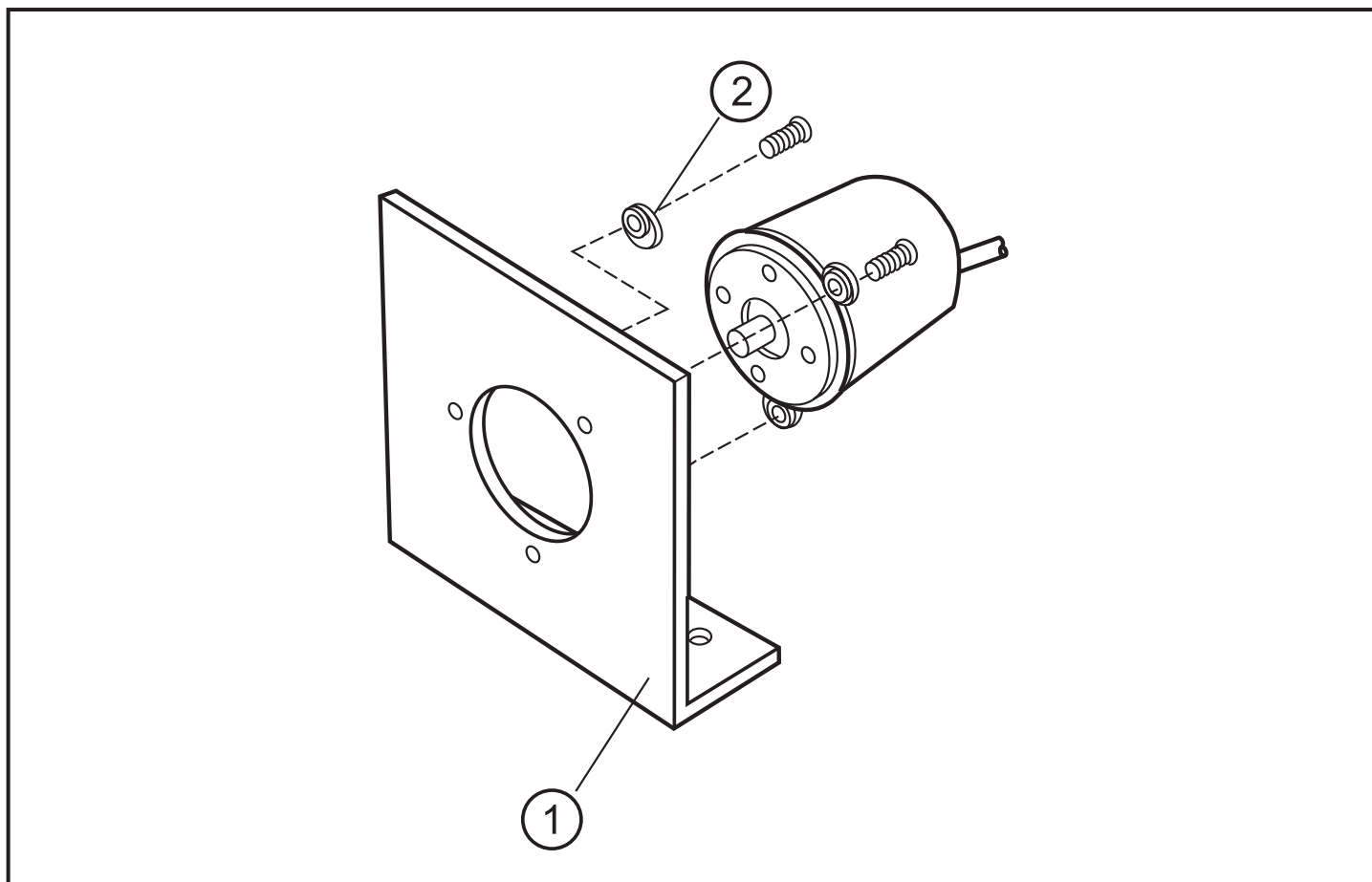

- 1: angle bracket
2: fastening clamp (3 pieces) E60041

4.2 Installation hollow shaft encoder

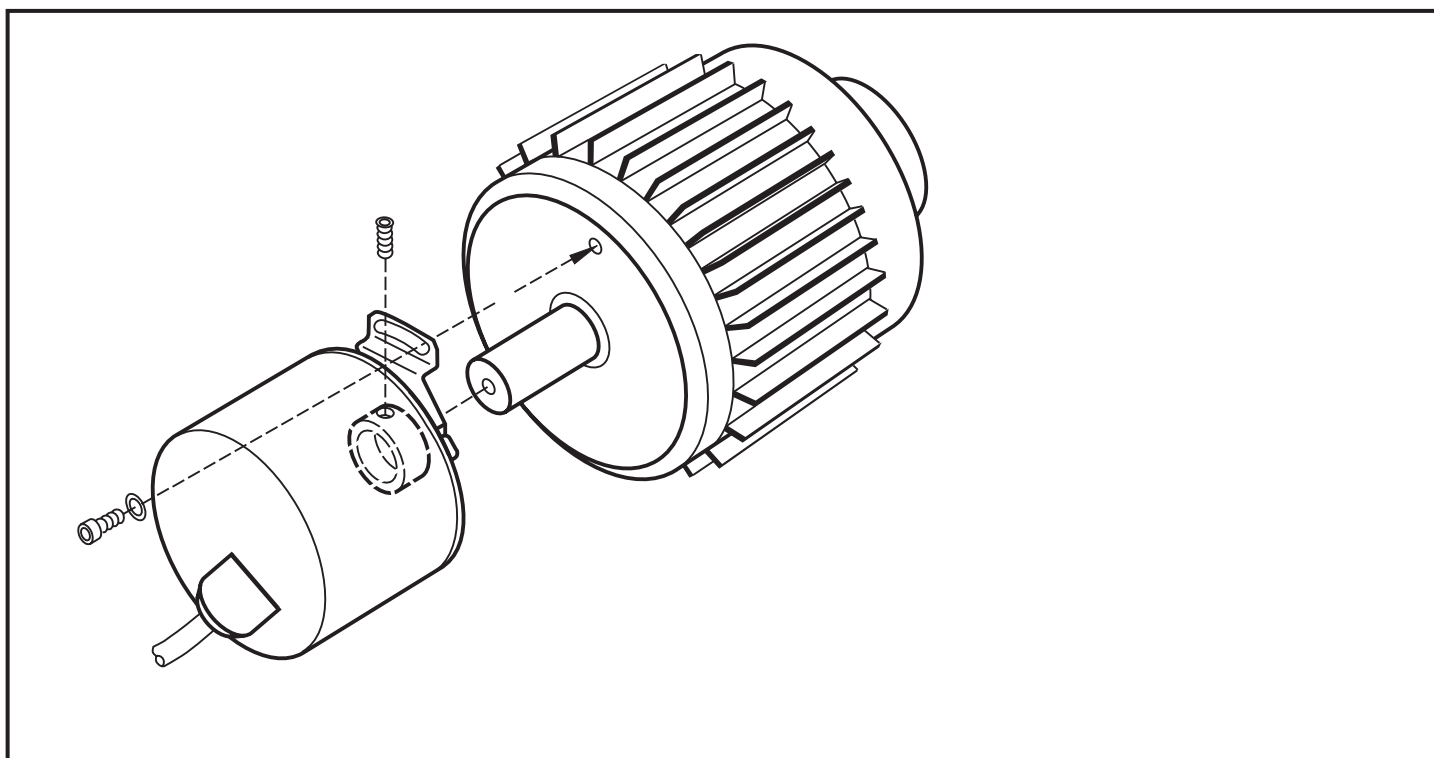

UK

- ▶ Place the clamping nut on the encoder.
- ▶ Slip the encoder onto the shaft (min. 10 mm) and fix the stator coupling by means of one M3 screw.
- ▶ Tighten the screws of the clamping nut.
- ▶ Connect encoder and drive by means of a flexible coupling.
- > Avoid damage to the shaft and the bearing.
- ▶ In case of linear measurement with a measuring wheel, encoder and measuring wheel should be mounted on the end of a flexible arm.

5 Electrical connection



The unit must be connected by a qualified electrician.

The national and international regulations for the installation of electrical equipment must be adhered to.

- ▶ Disconnect power.
- ▶ Connect the device according to the indications on the type label.

5.1 Laying the cable

- Extension by means of a screened extension cable; max. length 100 m.
- ▶ lay separately from sources of interference (minimum spacing 0.2 m).

- ▶ Connect and ground the encoder housing, the connector/ terminal box and the evaluation electronics via the screen.
- ▶ Connect the device according to the indications on the type label.

5.2 Standard wiring

white / pin 3	brown / pin 1	green / pin 2	yellow / pin 4	grey / pin 5	pink / pin 6
0 V sensor	U_b sensor	clock	clock (inv.)	data	data (inv.)

blue / pin 7	red / pin 8	screen
reset to zero	reversal of direction of rotation	housing

6 Operation

6.1 Data signals

Code signal data input:

TTL compatible signals, clock and clock (inv.) from driver to RS 422

Code signal data output:

synchronous serial, TTL compatible signals data and data (inv.)

6.1.2 Triggering of a data word

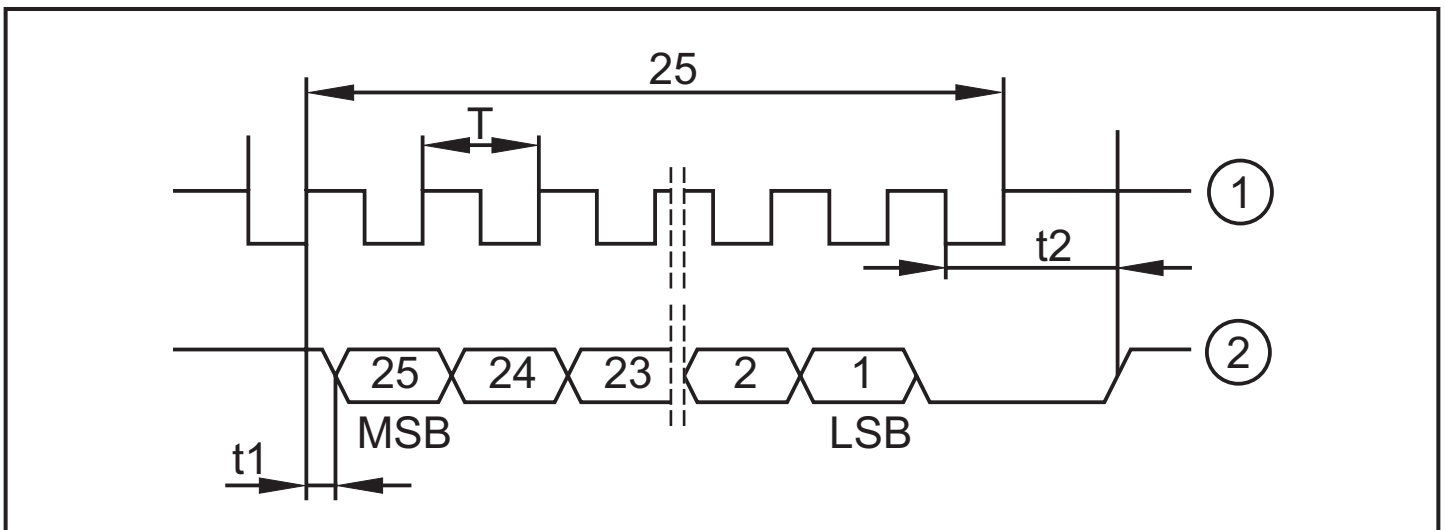

1: clock

2: data

$T = 1...10 \mu s$ / $t_1 \leq 0.4 \mu s$ (without cable) / $t_2 = 17...20 \mu s$ (waiting time)

In quiescent condition the clock and data lines are "high". The current measured value is stored with the first falling clock edge. Data transfer begins with the first rising clock edge.

After transfer of a complete data word the data output remains low during the time t_2 , only then is the encoder ready to transmit the next measured value. If during this time there is a new request for data output (clock), the data which have already been provided are provided again.

In this case the data output is "low" between LSB (Least Significant Bit) of the first transfer and MSB (Most Significant Bit) of the second transfer. UK

If the data output is interrupted ($\leq t_2$), a new measured value is stored with the next clock edge. The external electronics reads the data with the rising clock edge.

6.1.3 Level of the control inputs

When the control inputs Reset to zero and Reversal of the direction of rotation are used, the following requirements for the signal levels have to be adhered to:

not active: $LOW < 0.25 \times U_b$ / active: $HIGH > 0.6 \times U_b$

Switching time: min. $> 1 \text{ ms}$

Reversal of direction of rotation

By permanent application of a high level to the red wire / pin 8, the direction of rotation for increasing position values is reversed.

Reset to zero

To use the function Reset to zero, the shaft has to be stopped. A reset to zero when the shaft is rotating can lead to incorrect position values. The current position value is reset to zero if a positive edge is applied to the blue wire / pin 7 for at least 1 ms.

7 Maintenance, repair, disposal

The operation of the unit is maintenance-free. It is not possible to repair the unit. After use dispose of the unit in an environmentally friendly way in accordance with the applicable national regulations.

Technical data and further information at

www.ifm.com