

Your Global Automation Partner

TURCK

Encoder QR24 with an Incremental Interface

Operating instructions



Contents

1	About these instructions	5
1.1	Target groups	5
1.2	Explanation of symbols	5
1.3	Additional documents	5
1.4	Feedback on these instructions	5
2	Notes on the product	6
2.1	Product identification	6
2.2	Scope of delivery	7
2.3	Legal requirements	7
2.4	Manufacturer and service	7
3	For your safety	7
3.1	Intended use	7
3.2	Obvious misuse	8
3.3	General safety instructions	8
4	Product description	8
4.1	Device overview	8
4.1.1	Display elements	9
4.2	Properties and characteristics	9
4.3	Functional principle	9
4.4	Functions and operating modes	9
4.4.1	Output function	9
4.4.2	Burst output	9
4.5	Encoder – components and accessories	10
4.5.1	Encoder – sensor QR24	10
4.5.2	Encoder – positioning element QR24	10
4.5.3	Encoder – reducing sleeves QR24	12
4.5.4	Encoder – protecting rings and mounting kits for device types QR24/EQF24	13
4.5.5	Encoder – Sensor EQR24	14
4.5.6	Encoder – positioning element EQR24	14
4.5.7	Encoder – reducing sleeves EQR24	14
4.5.8	Encoder – general accessories	15
5	Assembly	16
5.1	Front installation – shaft diameter up to 20 mm	16
5.2	Rear installation – shaft diameter up to 20 mm	17
5.3	Installation on a larger rotating machine part	17
6	Connection	18
7	Commissioning	18
8	Operation	18
8.1	Maximum speed	18
8.2	LED display	19
9	Setting	19
9.1	Set via the Easy-Teach function	20

9.1.1	Set via teach buttons	20
9.2	Set via manual bridging (short-circuit)	21
9.3	Set via PACTware™ (FDT/DTM)	22
10	Eliminate interference	23
11	Maintenance	23
12	Repairs	23
12.1	Returning devices	23
13	Decommissioning	23
14	Disposal	23
15	Specifications	24
15.1	Default settings	25

1 About these instructions

These operating instructions describe the structure, functions and the use of the product, and will help you to operate the product as intended. Read these instructions carefully before using the product, and retain them for future use during the service life of the product. If the product is passed on, pass on these instructions too.

1.1 Target groups

These instructions are aimed at qualified personnel and must be carefully read by anyone mounting, commissioning, operating, maintaining, dismantling or disposing of the device.

1.2 Explanation of symbols

The following symbols are used in these instructions:



WARNING

WARNING indicates a potentially hazardous situation with a medium risk of death or serious injury if it is not prevented.



CAUTION

CAUTION indicates a situation that may result in damage to property if it is not prevented.



NOTE

NOTE indicates tips, recommendations and important information. The notes will make work easier, contain information on specific action steps and help prevent more work due to incorrect processes.



CALL TO ACTION

This symbol identifies action steps that the user has to perform.



ACTION RESULT

This symbol identifies relevant results of actions and action sequences.

1.3 Additional documents

You will find supplementary documents online at www.turck.com:

- Data sheet

1.4 Feedback on these instructions

We are committed to always keeping these instructions as informative and as clear as possible. Should you have any suggestions for a better design or any information is missing from the instructions, please send your suggestions to techdoc@turck.com.

2 Notes on the product

2.1 Product identification

Ri 360 P1 - QR24 M1 - INCR X2 - H1 1 8 1

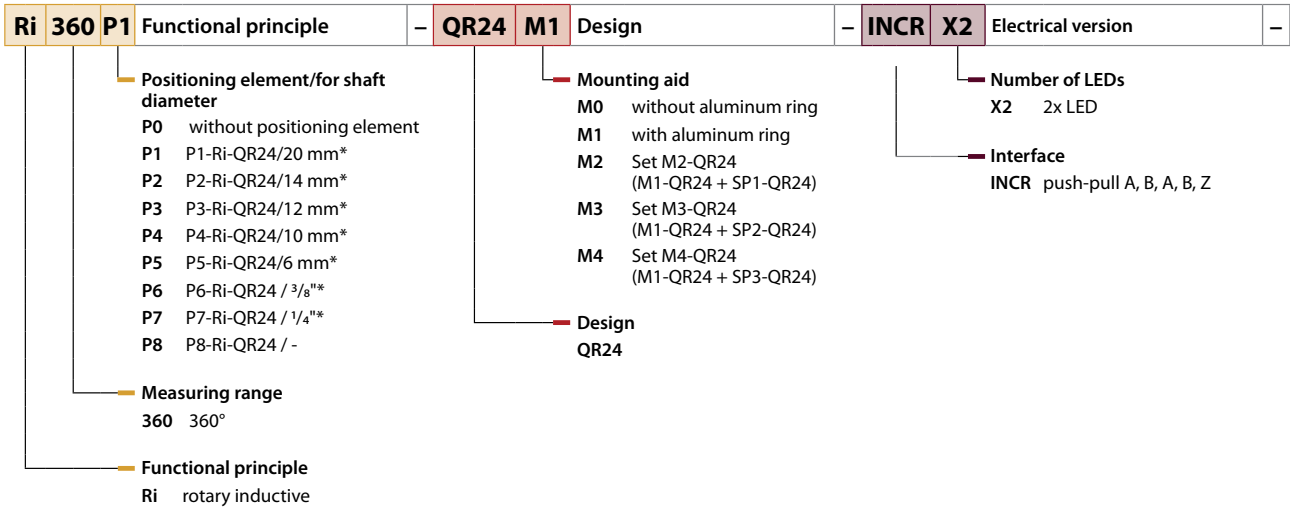

* Positioning element with hollow shaft

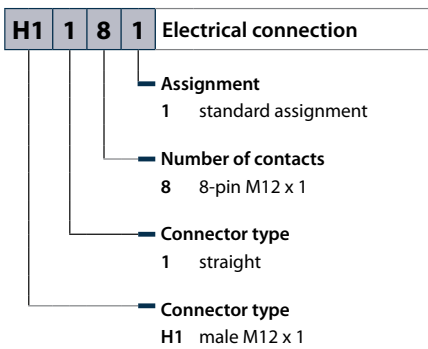

NOTE

Sensor, mounting element and the positioning element of the encoder are available both as single components and in the complete set.

2.2 Scope of delivery

Included in the scope of delivery:

- Encoder – sensor
- Adapter sleeve MT-QR24
- Instruction manual in brief
- Optional: Positioning and mounting element

2.3 Legal requirements

The device falls under the following EU directives:

- 2004/108/EC (electromagnetic compatibility)
- 2012/19/EU (WEEE II)

2.4 Manufacturer and service

Turck supports you with your projects, from initial analysis up to and commissioning of your application. The Turck product database contains software tools for programming, configuration or commissioning, data sheets and CAD data in various export formats. You can access the product database at the following address: www.turck.de/products

Should you have any further questions, please contact the sales and service team in Germany under the following telephone numbers:

Sales: +49 208 4952-380

Technology: +49 208 4952-390

Outside Germany, please contact your Turck representative.

Hans Turck GmbH & Co. KG
 Witzlebenstraße 7
 45472 Mülheim an der Ruhr
 Germany

3 For your safety

The product is designed according to the state of the art technology. However, residual risks still exist. Observe the following warnings and safety regulations to prevent danger to persons and property. Turck accepts no liability for damage caused by failure to observe these warning and safety instructions.

3.1 Intended use

These devices are designed for use in industrial areas. When used in other areas, the devices can cause electromagnetic interference.

The encoders of the Ri360...-QR24 ... INCR series with incremental output are used to measure speeds and angular movements. To do this, the devices absorb mechanical rotary movements and convert them into electrical pulse sequences. Per revolution, a defined number of pulses is emitted.

The devices may only be used as described in this manual. Any other use is not in accordance with the intended use. Turck accepts no liability for any resulting damage.

3.2 Obvious misuse

Any use that exceeds the maximum permissible speed of 10,000 rpm is deemed to be not in accordance with the intended purpose. The devices are not safety components and may not be used for personal or property protection.

3.3 General safety instructions

- The device may only be assembled, installed, operated, set up and maintained by professionally-trained personnel.

4 Product description

The inductive encoders of the RI360-QR24 series measure speeds and angular movements up to 360°. The sensor and positioning element of the encoders are fully encapsulated and are designed as two independent and fully sealed units with protection to IP68/IP69K, which work together without contact. The optional reducing sleeves and mounting elements allow the rotary encoder sensor to be mounted on the front and rear, on shafts with a diameter of up to 20 mm. There is also a mounting element for mounting on larger rotating machine parts in the program.

The devices are available as absolute rotary encoders with various output variants and as incremental encoders. For use in the food industry, a rugged stainless steel variant EQR24 is available.

The QR24 encoder with incremental output has a push-pull/HTL output with A-, \bar{A} -, B-, \bar{B} -, and Z-track. The number of pulses per revolution can be freely parameterized between 1 and 5000 with the Framework Program PACTware™ (FDT/DTM). Alternatively, the nine most common pulse counts can be set from the easy teach-in function of the encoder.

4.1 Device overview

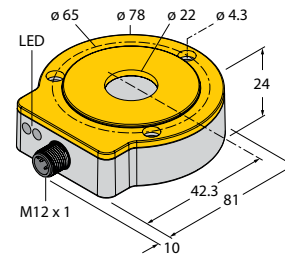
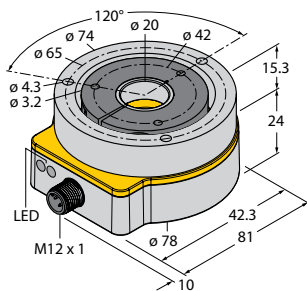

Fig. 1: Encoder QR24 with sensor, positioning element P1 (optional) and protecting ring (optional)

Fig. 2: Encoder – sensor (front side)

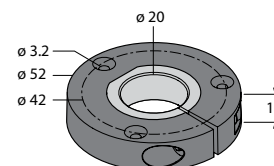
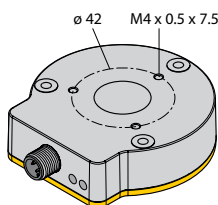

Fig. 3: Encoder – sensor (rear)

Fig. 4: Encoder – positioning element P1

4.1.1 Display elements

The devices have a green power LED and a yellow status LED.

4.2 Properties and characteristics

- The number of pulses per revolution (360, 512, 1000, 1024, 2048, 2500, 3600, 4096, 5000) can be parameterized via EASY-Teach
- Pulse number in the range of 1 to 5000 via PACTware™ (FDT/DTM) can be freely parameterized
- Position of the Z-track free selectable
- Burst output: incremental output of the absolute angular position
- Max. switching frequency 200 kHz
- CW/CCW rotation direction can be set
- Push-pull, track A, B, Z, A (inverse), B (inverse)

4.3 Functional principle

The QR24 encoders work contact-free on the basis of the inductive resonator measurement principle. This measuring principle allows for a design without seals, with fully sealed sensor housing that is separate from the positioning element. The measuring principle is resistant to magnetic fields, because the positioning element is not based on a magnet but on an inductive coil system where the sensor and position sensor (resonator) form an oscillating circuit. The inductive measuring principle of the QR24 encoder is absolute. To achieve an incremental output signal from the absolute angle, the sensor detects the actual angle for each millisecond and calculates the number of output pulses from this.

4.4 Functions and operating modes

4.4.1 Output function

The output signal of the incremental encoder QR24 INCR is based on the HTL interface (High Transistor Logic). In addition to tracks A and B, the inverted signals A (inverse) and B (inverse) are output; a Z-track is also available.

The QR24 is an absolute encoder that calculates the pulses of a clock cycle and emits these pulses according to the clock cycle within 800 µs. The cycle duration is therefore not inversely proportional to the speed of rotation. The angle sensing for positioning is carried out exactly according to the number of output pulses.

The number of output pulses can be freely configured between 1 and 5000.

For the output signal evaluation, we recommend standard input cards or counter blocks that can process a minimum pulse frequency of 80 kHz, otherwise incorrect counts may occur (e.g. Motrona DX-345).

4.4.2 Burst output

By triggering a burst output, it is possible for the position measured as an absolute value by the QR24 encoder to be output uniquely as an incremental pulse sequence with a frequency of 10 kHz. This corresponds to the number of pulses of the angular distance to the zero point (single-turn) in the set effective direction and resolution. The burst output is triggered via the Easy-Teach function (see section "Setting").

4.5 Encoder – components and accessories

4.5.1 Encoder – sensor QR24

Dimension drawing	Type	Description
	Ri360...-QR24	Encoder – sensor, type QR24, zinc die-cast housing

4.5.2 Encoder – positioning element QR24

The positioning elements are connected to the moving part of the machine (shaft), but move freely (without mechanical connection with the sensor) on the active surface of the sensor. For adaptation to the respective shaft diameters, positioning elements with different reducing sleeves are available.

Dimension drawing	Type	Description
	PE1-QR24	Positioning element without reducing sleeve with stainless steel fitting
	P1-Ri-QR24	Positioning element with reducing sleeve for connection on shafts with a diameter of 20 mm
	P2-Ri-QR24	Positioning element with reducing sleeve for connection on shafts with a diameter of 14 mm
	P3-Ri-QR24	Positioning element with reducing sleeve for connection on shafts with a diameter of 12 mm

Dimension drawing	Type	Description
	P4-Ri-QR24	Positioning element with reducing sleeve for connection on shafts with a diameter of 10 mm
	P5-Ri-QR24	Positioning element with reducing sleeve for connection on shafts with a diameter of 6 mm
	P6-Ri-QR24	Positioning element with reducing sleeve for connection on shafts with a diameter of 3/8"
	P7-Ri-QR24	Positioning element with reducing sleeve for connection on shafts with a diameter of 1/4"
	P8-Ri-QR24	Positioning element with blanking plugs, e.g. for mounting on larger rotating machine parts

4.5.3 Encoder – reducing sleeves QR24

Various reducing sleeves are offered for the adjustment of the positioning elements to the respective shaft diameters.

Dimension drawing	Type	Description
	RA1-QR24	Reducing sleeve for connection on shafts with a diameter of 20 mm
	RA2-QR24	Reducing sleeve for connection on shafts with a diameter of 14 mm
	RA3-QR24	Reducing sleeve for connection on shafts with a diameter of 12 mm
	RA4-QR24	Reducing sleeve for connection on shafts with a diameter of 10 mm
	RA5-QR24	Reducing sleeve for connection on shafts with a diameter of 6 mm
	RA6-QR24	Reducing sleeve for connection on shafts with a diameter of 3/8"
	RA7-QR24	Reducing sleeve for connection on shafts with a diameter of 1/4"

RA8-QR24

Blanking plugs for mounting without reducing sleeve (e.g. installation of the position sensor to larger rotating machine parts)



4.5.4 Encoder – protecting rings and mounting kits

For the various mounting types (see section "Mounting"), various mounting kits are required. Each mounting kit contains an aluminum protecting ring and an aluminum screening plate. Depending on the mounting type and application, the screening plate can be used to increase the signal quality between the position sensor and the sensor. The protecting rings are also available individually in aluminum and plastic.

Dimension drawing	Type	Description
	M1-QR24	Aluminum ring
	SP1-QR24	Aluminum screening plate SP1-QR24: diameter 74 mm For front-panel mounting of the sensor on shafts with a diameter of up to 20 mm
	SP2-QR24	Aluminum screening plate SP2-QR24: diameter 74 mm, with 22 mm diameter hole for shaft implementation for rear mounting of the sensor on shafts up to a diameter of 20 mm
	SP3-QR24	Aluminum screening plate SP3-QR24: diameter 52 mm for mounting the positioning element on larger rotating machine parts
	M5-QR24	Plastic protecting ring

4.5.5 Encoder – Sensor EQR24

Dimension drawing	Type	Description
	Ri360P...-EQR24	Encoder – sensor, type QR24, stainless steel housing

4.5.6 Encoder – positioning element EQR24

Dimension drawing	Type	Description
	PE-EQR24	Positioning element without reducing sleeve with stainless steel fitting
	P1-Ri-EQR24	Positioning element with reducing sleeve for connection on shafts with a diameter of 20 mm, stainless steel fitting
	P3-Ri-EQR24	Positioning element for connecting on shafts with a diameter of 12 mm Stainless steel fitting
	P4-Ri-EQR24	Positioning element with reducing sleeve for connection on shafts with a diameter of 10 mm, stainless steel fitting

4.5.7 Encoder – reducing sleeves EQR24

Dimension drawing	Type	Description
	RA1-EQR24	Stainless steel reducing sleeve for connection on shafts with a diameter of 20 mm

Dimension drawing	Type	Description
	RA3-EQR24	Stainless steel reducing sleeve for connection on shafts with a diameter of 12 mm
	RA4-EQR24	Stainless steel reducing sleeve for connection on shafts with a diameter of 10 mm

4.5.8 Encoder – general accessories

Dimension drawing	Type	Description
	MT-QR24	Mounting aid for optimal alignment of the position sensor (included in delivery)
	RKC8.302T-1,5-RSC4T/TX320	Adapter cable to connect the sensor to the USB-IO-Link-Adapter USB-2-IOL-0002 M12 female connector, straight, 8-pin, female M12, straight, 3-pin; cable length 1.5 m; sheath material: PUR; sheath color: black, cULus approved, RoHS conform, protection class IP67
	RKC8T-2/TXL	Connection cable, female M12, straight, 8-pin, cable length 5 m sheath material: PUR, black; suitable for trailing, weld splatter resistant, chemical, UV and oil-resistant, flame-retardant, halogen, silicone, PVC and LABS-free, particularly abrasion-resistant; cULus approved; RoHS compliant; degree of protection IP67; other cable lengths and types available, see www.turck.com
	RKS8T-5/TEL	Connection cable, M12 female, straight, 8-pin, stainless steel coupling nut, cable length 5 m, sheath material: PVC, black; cULus approval; other cable lengths and qualities available, see www.turck.com
	TX2-Q20L60	Teach-adaptor for parameterization
	USB-2-IOL-0002	IO-Link adapter with integrated USB interface

5 Assembly

With the optional reducing sleeves and mounting elements, the encoder sensor can be mounted on the front and back of shafts with a diameter of up to 20 mm. In the case of larger rotating machine parts, the positioning element is screwed directly onto the machine part and is not inserted onto the shaft:



WARNING

Improper mounting

Possible danger to life from swinging components!

- Installation instructions must be observed.
- Check the fixed seat position, tightening torque:
M = 0.6...0.8 Nm.



CAUTION

Metallic conversion on the positioning element is too narrow

Loss of function due to weakening of the oscillating circuit!

- Check there is sufficient distance between conversion and positioning element.
- Before commissioning, carry out a function test.



NOTE

Before switching on the supply voltage, the positioning element must be located centrally in the detection range of the sensor.

5.1 Front installation – shaft diameter up to 20 mm

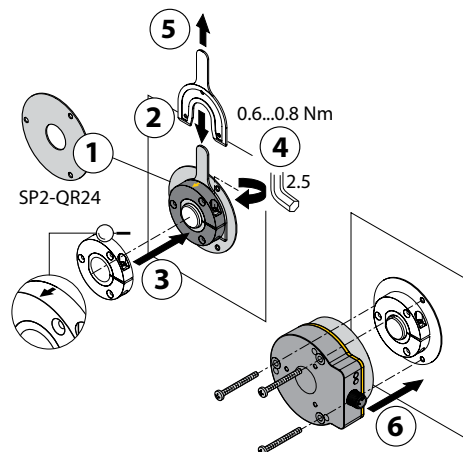

Fig. 5: Front installation-
shaft diameter up to 20 mm

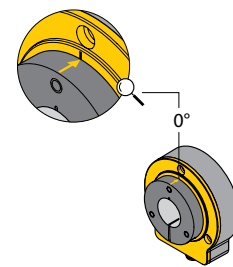

Fig. 6: Zero point default value

- ① Optional: Install shield plate SP2-QR24.
 - ② Mounting aid for optimal alignment of the positioning element.
 - ③ Slide the positioning element—with front side (active area) facing the shaft—onto the shaft.
 - ④ Secure the clamping fitting of the positioning element with an Allen key.
 - ⑤ Remove the mounting aid.
 - ⑥ Lay the encoder sensor incl. protecting ring with the front side facing the shaft via the positioning element and align it to the desired position of the zero point. (Factory setting for 0°: yellow arrow on the position sensor points to black marks on the sensor, see figure "zero point default value").
- Secure the rotary encoder with three screws to form a closed and protected unit.

5.2 Rear installation – shaft diameter up to 20 mm

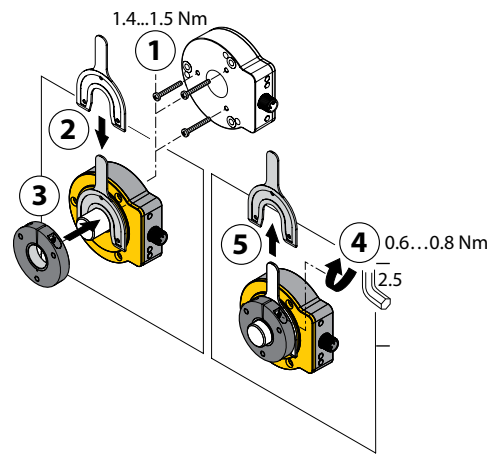

Fig. 7: Rear installation - shaft diameter up to 20 mm

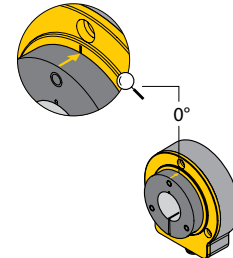

Fig. 8: Zero point default value

- ① Slide the encoder sensor—with the rear side to the shaft—onto the shaft and secure with the three screws.
 - ② Mounting aid for optimal alignment of the positioning element.
 - ③ Slide the positioning element onto the shaft and arrange it to the desired position of the zero point. (Factory setting for 0°: yellow arrow on the position sensor points to black marks on the sensor, see figure "zero point default value").
 - ④ Secure the clamping fitting of the positioning element with an Allen key.
 - ⑤ Remove the mounting aid.
- Optional: Protection ring and screening plate SP1-QR24.

5.3 Installation on a larger rotating machine part

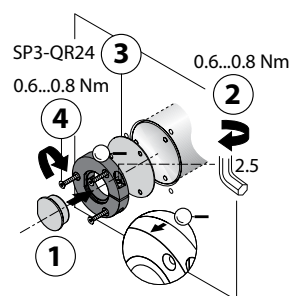

Fig. 9: Install on a larger rotating machine parts

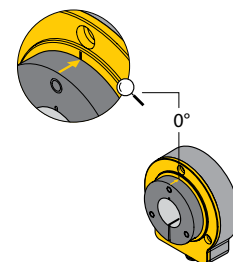

Fig. 10: Zero point default value

- ① If it does not yet exist: Fit the blind plug RA8-QR24 in the positioning element.
 - ② Secure the clamping fitting of the positioning element with an Allen key.
 - ③ Optional: Abschirmplatte SP3-QR24 einsetzen.
 - ④ Mount the positioning element on three M3 countersunk head screws (recommendation: stainless steel screws).
- Then mount the rotary encoder depending on the application and arrange to the desired position of the zero point (factory setting for 0°: yellow arrow shows the positioning element points to the black mark on the sensor, see figure "zero point default value").

6 Connection

The rotary encoder has an 8-pin M12 × 1 male connector with incremental output.

Connection image	Pin	Signal	Assignment
	1	GND	GND/0 V/V-
	2	24 VDC	Power supply (+24 VDC)
	3	O	Track A
	4	\bar{O}	Track A inverted
	5	B	Track B
	6	\bar{B}	Track B inverted
	7	Z	Track Z
	8	Teach/prog.	Parameterization/Easy-Teach input



NOTE

To avoid unintended teaching, keep pin 8 potential-free.

7 Commissioning

After connecting and switching on the power supply, the device is automatically ready for operation.

8 Operation

8.1 Maximum speed



WARNING

Improper mounting

Possible danger to life from loose components!

- Maximum speed of 10,000 rpm must not be exceeded.
- Installation instructions must be observed.
- Check the positioning element has a secure fit at regular intervals, tightening torque: $M = 0.6 \dots 0.8 \text{ Nm}$.

The maximum usable speed of the rotary encoder is 10,000 rpm. However, at high resolutions it is limited by the maximum output frequency of 200 kHz. The dependence of the max. speed of the resolution is illustrated in the following diagram:

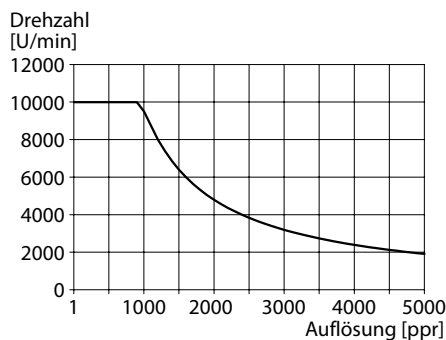

Fig. 11: Maximum usable speed depending on the resolution

8.2 LED display

In normal operation, the green power LEDs and the yellow status LEDs have the following display functions:

Color/status	Meaning
green	Sensor is being supplied properly.
yellow	Positioning element is in the measuring range with limited signal quality (e.g. distance too great).
yellow flashing	Positioning element is outside the detection range.
off	The position sensor is located in the entry area.

9 Setting

The rotary encoder can be parameterized as follows:

- Set via Easy-Teach function
- Set via manual bridging (short-circuit)
- Set via PACTware™ (FDT/DTM)



NOTE

When connecting and disconnecting the IO-Link USB minimal device, an accidental teach process may be triggered. Check the settings before commissioning in the application.

The following parameters can be set:

Parameters	Description
Zero point	Zero point: Position of the Z-signal.
Effective mode	CW/CCW: Feed A-track or B-track.
Pulse number	Resolution: 1 ... 5000 pulses per revolution (can only be adjusted via Easy-Teach and PACTware™)
Burst trigger output	The position measured by QR24 rotary encoder as an absolute value is output once as an incremental pulse sequence. This corresponds to the number of pulses of the angular distance to the zero point (single-turn) in the set effective direction and resolution.

The factory settings can be found in the section "Technical data".

9.1 Set via the Easy-Teach function

The devices can be taught via the Easy-Teach function as follows:

	teach-in against GND	teach-in against U _B
Teach adapter	Press button against GND	Press button against U _B
manual bridging (short-circuit)	Short-circuit pin 1 with pin 8	Short-circuit pin 2 with pin 8

Using a relay, the device can be set automatically via the Easy-Teach function.

9.1.1 Set via teach buttons

The teach-in adapter TX2-Q20L60 is not included in delivery and must be ordered separately. The adapter is connected between the sensor and connection cable for teaching-in.

Set the position of the Z-signal (zero point)

Prerequisites: Positioning element is mounted (yellow status LED is off)

- Specify the selected zero point with the yellow arrow marking on the positioning element (factory setting for 0°: yellow arrow on the positioning element points to black marking on the sensor)
- Press and hold the button on the adapter for 2 seconds against GND.
- If the status LED is permanently lit after 2 seconds, the position of the Z-signal has been successfully taught.

Burst trigger output

Prerequisites: Position encoder is mounted (yellow status LED is off).

- Press and hold the button on the adapter for 2 seconds against U_B.
- If the status LED is permanently lit after 2 seconds, the burst output is successfully triggered.

Set the effective direction of the encoder CW

Prerequisites: Positioning element is mounted (yellow status LED is off)

- Press and hold the button on the adapter for 10 seconds against U_B.
- If the status LED flashes rapidly for 2 seconds, the effective direction is set successfully in the clockwise direction.

Set the effective direction of the encoder CCW

Prerequisites: Positioning element is mounted (yellow status LED is off)

- Press and hold the button on the adapter for 10 seconds against GND.
- If the status LED flashes rapidly for 2 seconds, the effective direction is successful in the counterclockwise direction.

Reset the device to factory settings

Prerequisites: Positioning element is mounted (yellow status LED is off)

- Press and hold the button on the adapter for 15 seconds against U_B.
- If the power LED and the status LED flash alternately, the device has successfully been reset to the factory setting.

Set the pulses per revolution in the preset mode (360...2048 pulses per revolution)

- Remove the position sensor (yellow status LED flashes).
- Press and hold the button on the adapter for 2 seconds against GND.
- The pulse selection is enabled for 10 seconds.
- Select the desired pulse number in accordance with the following table:

Pulses per revolution	Briefly press the button to GND	Teach successful
360	Start value (do not press)	Status LED flashes 1 x
512	1 x	Status LED flashes 2 x
1000	2 x	Status LED flashes 3 x
1024	3 x	Status LED flashes 4 x
2048	4 x	Status LED flashes 5 x

Set the pulses per revolution in the preset mode (2500...5000 pulses per revolution)

- Remove the position sensor (yellow status LED flashes).
- Press and hold the button on the adapter for 2 seconds against U_B .
- The pulse selection is enabled for 10 seconds.
- Select the desired pulse number in accordance with the following table:

Pulses per revolution	Briefly press the button against U_B	Teach successful
2500	Start value (do not press)	Status LED flashes 1 x
3600	1 x	Status LED flashes 2 x
4096	2 x	Status LED flashes 3 x
5000	3 x	Status LED flashes 4 x

9.2 Set via manual bridging (short-circuit)

Set the position of the Z-signal (zero point)

Prerequisites: Positioning element is mounted (yellow status LED is off)

- Specify the selected zero point with the yellow arrow marking on the positioning element (factory setting for 0°: yellow arrow on the positioning element points to black marking on the sensor)
- Bridge pin 1 (GND) and pin 8 for 2 seconds.
- If the status LED is permanently lit after 2 seconds, the position of the Z-signal has been successfully taught.

Burst trigger output

Prerequisites: Position encoder is mounted (yellow status LED is off).

- Bridge pin 2 (U_B) and pin 8 for 2 seconds.
- If the status LED is permanently lit after 2 seconds, the burst output has been successfully initiated.

Set the effective direction of the encoder CW

Prerequisites: Positioning element is mounted (yellow status LED is off)

- Bridge pin 2 (U_B) and pin 8 for 10 seconds.
- If the status LED flashes for 2 seconds, the effective direction is successful in a clockwise direction.

Set the effective direction of the encoder CCW

Prerequisites: Positioning element is mounted (yellow status LED is off)

- Bridge pin 1 (GND) and pin 8 for 10 seconds.
- If the status LED flashes for 2 seconds, the effective direction is successful in the counterclockwise direction.

Reset the device to factory settings

Prerequisites: Positioning element is mounted (yellow status LED is off)

- Bridge pin 2 (U_B) and pin 8 for 15 seconds.
- If the power LED and the status LED flash alternately, the device has successfully been reset to the factory setting.

Set the pulses per revolution in the preset mode (360...2048 pulses per revolution)

- Remove the position sensor (yellow status LED flashes).
- Bridge pin 1 (GND) and pin 8 for 2 seconds.
- The pulse selection is enabled for 10 seconds.
- Select the desired pulse number in accordance with the following table:

Pulses per revolution	Briefly bridge pin 1 with pin 8	Teach successful
360	Start value (do not bridge)	Status LED flashes 1 x
512	1 x	Status LED flashes 2 x
1000	2 x	Status LED flashes 3 x
1024	3 x	Status LED flashes 4 x
2048	4 x	Status LED flashes 5 x

Set the pulses per revolution in the preset mode (2500...5000 pulses per revolution)

- Remove the position sensor (yellow status LED flashes).
- Bridge pin 2 (U_B) and pin 8 for 2 seconds.
- The pulse selection is enabled for 10 seconds.
- Select the desired pulse number in accordance with the following table:

Pulses per revolution	Briefly bridge pin 2 with pin 8	Teach successful
2500	Start value (not bridged)	Status LED flashes 1 x
3600	1 x	Status LED flashes 2 x
4096	2 x	Status LED flashes 3 x
5000	3 x	Status LED flashes 4 x

9.3 Set via PACTware™ (FDT/DTM)

The devices can use a PC with an FDT frame application (e.g. PACTware™). All the necessary Turck software components can be downloaded via the Turck software manager:

- PACTware™
- IODD
- DTM for IO link adapter/USB-2-IOL-002

The Turck software manager can be downloaded free of charge at www.turck.com.

The IO-Link adapter USB 2-IOL-002 (ID no. 6825482) is needed to connect to a PC.

The cable RKC8.3 02T-1,5-RSC4T/TX320 (ID no. 6625003) is needed to connect the sensor to the IO-Link adapter USB 2-IOL-002.

For more information on how to adjust the devices via IODD using a configuration tool, refer to the commissioning manual for IO-Link (D900063).

10 Eliminate interference

The strength of the oscillating circuit coupling is displayed via an LED. Any faults are signaled by the LED.

If the device does not work as expected, first check whether ambient interference is present. If there is no ambient interference, check the connections of the device for faults.

If there are no faults, there is a device malfunction. In this case decommission the device and replace it with a new device of the same type.

11 Maintenance

Ensure that the plug connections and cables are always in good condition. The device is maintenance-free; if necessary clean dry.

12 Repairs

The device is not intended for repair by the user. If the device is faulty, please take it out of operation. If you are returning the device to Turck, please note our return terms and conditions.

12.1 Returning devices

If a device has to be returned, bear in mind that only devices with a decontamination declaration will be accepted.

This is available for download at http://www.turck.de/static/media/downloads/01_Declaration_of_decontamination_EN.pdf and must be completely filled in, and affixed securely and weather-proof to the outside of the packaging.

13 Decommissioning

- Remove the connection cable from the power supply and/or processing units.
- Remove the connection cable from the device.
- Undo the connections of the device or if necessary the mounting aid for the mounting area.
- If necessary, undo the connection of the device to the mounting aid.

14 Disposal



The device must be properly disposed of, not in general household waste.

15 Specifications

Measuring function – information	
Angular range	0...360°
max. rotational speed	10,000 U/min Determined with standardized construction, with a steel shaft diameter 20 mm, L = 50 mm and reducer ring diameter 20 mm
Resolution, incremental	1...5000 pulses per revolution (factory settings: 1024)
Effective mode	CW/CCW (factory setting: CW)
Z-track (zero point setting)	Factory setting: 0° (yellow arrow on the position sensor points to the black mark on the sensor)
Starting torque, shaft load	not applicable, because of contactless measuring principle
System	
Repeatability	≤ 0.01% full scale
Linearity deviation	≤ 0.05 % full scale
Temperature drift	≤ ± 0.003%/K
Ambient temperature	-25...+85 °C
Electrical data	
Operating voltage	10...30 VDC
Residual ripple	≤ 10 % U _{ss}
Rated insulation voltage	≤ 0.5 kV
Short-circuit protection	yes/cyclic
Wire breakage/reverse polarity protection	yes/yes (power supply)
Output function	8-pole, push-pull/HTL
Output type	incremental
Maximum pulse frequency	200 kHz
signal level high	min. U _B - 2 V
Signal level low	max. 2 V
rise time	max. 750 ns
fall time	max. 750 ns
Sampling rate	1000 Hz
Current consumption	< 100 mA
Housing	
Dimensions	81 × 78 × 24 mm
Connector	M12 × 1 male, 8-pin
Vibration resistance	55 Hz (1 mm)
Vibration resistance (EN 60068-2-6)	20 g; 10...3000 Hz; 50 cycles; 3 axes
Shock resistance (EN 60068-2-27)	100 g; 11 ms ½ sinus; each 3 x, 3 axes
Continuous shock resistance (EN 60068-2-29)	40 g; 6 ms ½ sinus; each 4000 x; 3 axes
IP Rating	IP68 / IP69K
MTTF	138 years according to SN 29500 (Ed. 99) 40 °C
LED display	
Operating voltage display	LED green
Status Indication	LED, yellow, yellow flashing

15.1 Default settings

Adjustment	
Resolution, incremental	1024 (default)
Effective mode	CW
Z-track (zero point setting)	Factory setting: 0° (yellow arrow on the position sensor points to the black mark on the sensor)

TURCK

28 subsidiaries and over
60 representations worldwide!

D102198 | 2016/05



www.turck.com