

ifm electronic



Installation instructions
Electronic pressure sensor
for mobile applications

UK

efectorsoo®

PT56xx/PU56xx

PT57xx/PU57xx

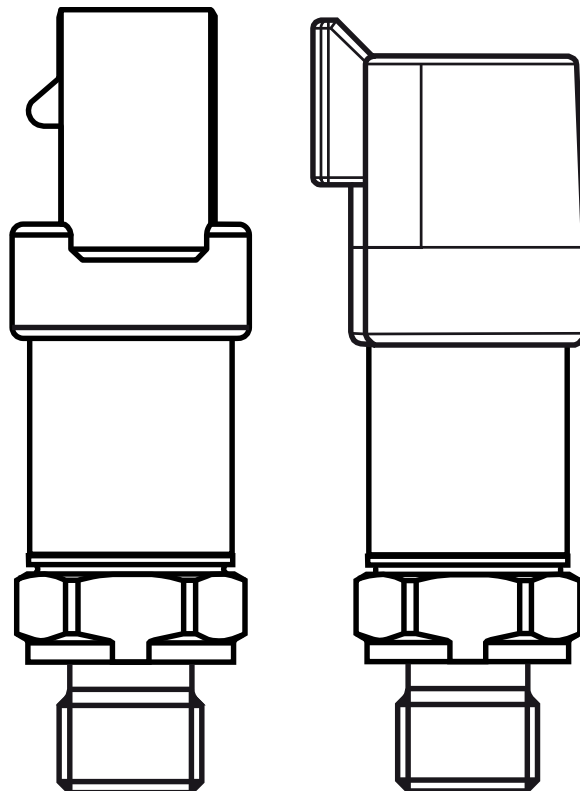

06 / 2015

80229960 / 00

Contents

1 Preliminary note.....	2
2 Safety instructions	2
3 Functions and features	3
3.1 Applications	3
3.2 Use in hydraulic systems of mobile machines.....	4
4 Functions	5
5 Installation.....	5
6 Electrical connection.....	6
7 Technical data and scale drawing.....	7

1 Preliminary note

Symbols used

▶ Instructions

→ Cross-reference



Important note

Non-compliance can result in malfunction or interference.



Information

Supplementary note.

2 Safety instructions

- Please read this document prior to set-up of the unit. Ensure that the product is suitable for your application without any restrictions.
- If the operating instructions or the technical data are not adhered to, personal injury and/or damage to property can occur.
- Improper or non-intended use may lead to malfunctions of the unit or to unwanted effects in your application. That is why installation, electrical connection, set-up, operation and maintenance of the unit must only be carried out by qualified personnel authorised by the machine operator.

- In order to guarantee the correct condition of the device for the operating time it is necessary to use the device only for media to which the wetted materials are sufficiently resistant (→ 7).
- The responsibility whether the measurement devices are suitable for the respective application lies with the operator. The manufacturer assumes no liability for consequences of misuse by the operator. Improper installation and use of the devices results in a loss of the warranty claims.

3 Functions and features

The pressure sensor detects the system pressure and converts it into an analogue output signal. UK

3.1 Applications

- Type of pressure: relative pressure

Order number	Final value of the measuring range (nominal pressure)		Static pressure resistance (max. permissible pressure)		Bursting pressure	
	bar	psi	bar	psi	bar	psi
AMP Superseal						
PT5604 / PU5604	10	145	25	360	300	4350
PT5603 / PU5603	25	360	65	940	600	8700
PT5602 / PU5602	100	1450	250	3625	1000	14500
PT5601 / PU5601	250	3625	625	9060	1200	17400
PT5600 / PU5600	400	5800	1000	14500	1700	24655
PT5660 / PU5660	600	8700	1500	21755	2500	36255
Deutsch DT04 3P						
PT5704 / PU5704	10	145	25	360	300	4350
PT5703 / PU5703	25	360	65	940	600	8700
PT5702 / PU5702	100	1450	250	3625	1000	14500
PT5701 / PU5701	250	3625	625	9060	1200	17400
PT5700 / PU5700	400	5800	1000	14500	1700	24655
PT5760 / PU5760	600	8700	1500	21755	2500	36255

$$\text{MPa} = \text{bar} \div 10 / \text{kPa} = \text{bar} \times 100$$



Avoid overload pressure exceeding the specified maximum permissible pressure by taking appropriate measures.

The indicated bursting pressure must not be exceeded.

Even if the bursting pressure is exceeded only for a short time, the unit may be destroyed. ATTENTION: Risk of injury!



For units with a final value of the measuring range of 600 bar the limits of the pressure cycles across the lifetime apply (→ 7).



Surge resistance

In order to achieve CE conformity, it must be ensured that the cable length used is restricted to max. 30 m!



Pressure Equipment Directive (PED):

- Units with a final value of the measuring range of 10...400 bar comply with the Pressure Equipment Directive and are designed and manufactured for group 2 fluids in accordance with the sound engineering practice.

Use of group 1 fluids on request!



Pressure Equipment Directive (PED):

The units with a final value of the measuring range of 600 bar comply with the Pressure Equipment Directive. They are designed for group 2 fluids and manufactured and tested according to Module A.

Use of group 1 fluids on request!

3.2 Use in hydraulic systems of mobile machines

Restrictor in the process connection:

In hydraulic systems of mobile machines, highly dynamic effects such as pressure peaks, cavitation etc. may arise depending on the operating conditions. To reduce these effects on the measuring element of the sensor, a diaphragm attachment is integrated into the process connection.

The specific thread pitch of the diaphragm attachment has the effect of a hole of 0.3 mm.



Please note:

High viscosity may reduce the response time by some milliseconds. Heavy soiling may affect the functionality.

4 Functions

Current output 4..20 mA (PT5xxx)	Voltage output 0 ... 10 V (PU5xxx)
<p>P = system pressure, MEW = final value of the measuring range</p>	
<p>In the measuring range the output signal is between 4 and 20 mA. If the system pressure is above or below the measuring range, the analogue output behaves, without achieving the accuracy, as follows:</p> <ul style="list-style-type: none"> • System pressure above the measuring range: 20...25 mA. • System pressure below the measuring range: 4...3 mA. 	<p>In the measuring range the output signal is between 0 and 10 V. If the system pressure is above the measuring range, the analogue output behaves, without achieving the accuracy, as follows:</p> <ul style="list-style-type: none"> • System pressure above the measuring range: 10...11.5 V.

5 Installation



Before installing and removing the unit: Make sure that no pressure is applied to the system.

- ▶ Insert the unit in a G $\frac{1}{4}$ process connection.
- ▶ Tighten firmly. Recommended tightening torque:

Final value of the measuring range in bar	Tightening torque in Nm
10...400	25...35
600	30...50
Depends on lubrication, seal and pressure rating!	

6 Electrical connection



The unit must be connected by a qualified electrician.

The national and international regulations for the installation of electrical equipment must be adhered to.

Voltage supply to EN 50178, SELV, PELV.

- ▶ Disconnect power.
- ▶ Connect the unit as follows:

PT56xx (4...20 mA analogue)

AMP Superseal	
OUT: Analogue output 4...20 mA.	

PT57xx (4...20 mA analogue)

Deutsch DT04 3P	
OUT: Analogue output 4...20 mA	

PU56xx (0...10 V analogue)

AMP Superseal	
OUT: Analogue output 0...10 V	

PU57xx (0...10 V analogue)

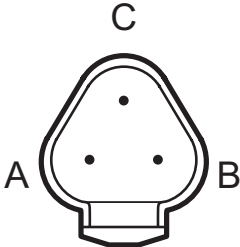
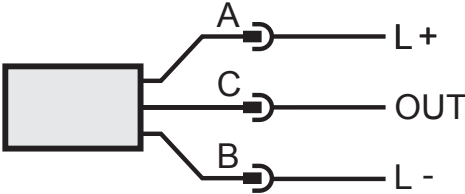
Deutsch DT04 3P	
	
OUT: Analogue output 0...10 V	

7 Technical data and scale drawing

UK

 Pressure Equipment Directive (PED) stipulates that the following technical data must be provided for units with a final value of the measuring range of 600 bar.

PT5660 / PT5760	
Operating voltage [V]	8...32 DC
Analogue output	4...20 mA
PU5660 / PU5760	
Operating voltage [V]	16...32 DC
Analogue output	0...10 V
Medium temperature [°C]	-40...125
Ambient temperature [°C]	-40...100
Storage temperature [°C]	-40...100
Pressure cycles (min.) across lifetime	60 million for 1.2 x nominal pressure
Shock resistance [g]	500 (DIN EN 60068-2-27, 1 ms)
Vibration resistance [g]	20 (DIN EN 60068-2-6, 10...2000 Hz)

Further technical data and scale drawing at www.ifm.com → New search → Enter the article number.

More information at www.ifm.com