

PRK 25B

Retro-reflective photoelectric sensors with polarisation filter

en 07-2016/05 50108917-02



0.05 ... 10m



- Polarised retro-reflective photoelectric sensor with visible red light
- High performance reserve
- Small and compact construction with robust plastic housing, protection class IP 66/IP 67 for industrial application
- Fast alignment through *brightVision*®
- A²LS - Active Ambient Light Suppression
- Push-pull switching outputs
- High switching frequency for detection of fast events
- Parallel connection of switching outputs
- Warning output for increased availability
- Operating range adjustment



Accessories:

(available separately)

- Mounting systems (BT 25, UMS 25...)
- Cable with M8 or M12 connector (K-D ...)
- Reflectors
- Reflective tapes

Dimensioned drawing

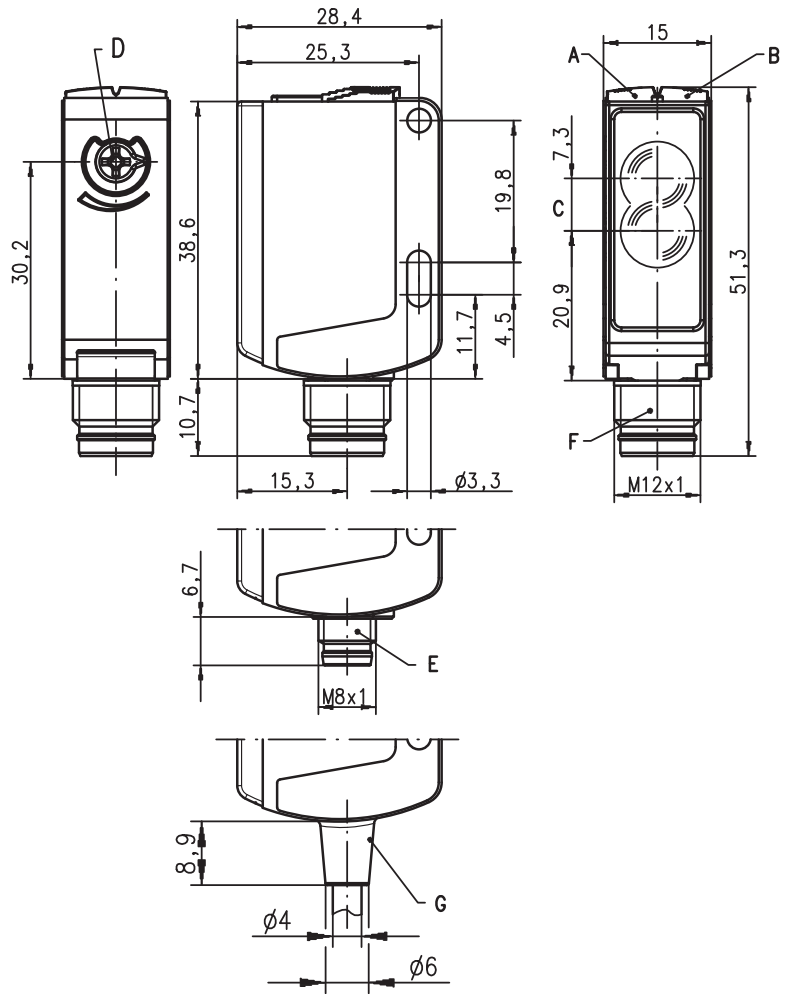

- A Green indicator diode
- B Yellow indicator diode
- C Optical axis
- D Operating range adjustment
- E Connector M8x1
- F Connector M12x1
- G Cable

Electrical connection

PRK 25B/66-S8
PRK 25B/66-S12
PRK 25B/66, 200-S12
PRK 25B/66.1-S12

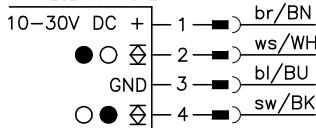

PRK 25B/66
PRK 25B/66,5000

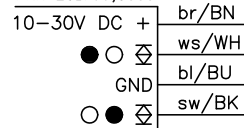

PRK 25B/4.8-S12

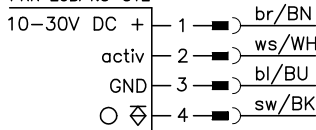

IPRK 25B/4-S12
IPRK 25B/4, 200-S12

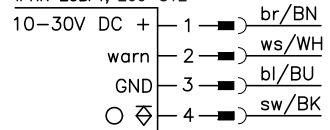

PRK 25B/44-S12

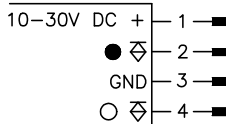

PRK 25B/4, 200-S8.1

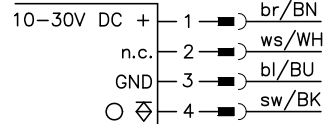

We reserve the right to make changes • DS_PRK25B4466_en_50108917_02.fm

Specifications

Optical data

Typ. op. range limit (TK(S) 100x100) ¹⁾ 0.05 ... 10m
 Operating range ²⁾ see tables
 Light source ³⁾ LED (modulated light)
 Wavelength 620nm (visible red light, polarised)

Timing

Switching frequency 500Hz
 Response time 1ms
 Delay before start-up ≤ 300ms

Electrical data

Operating voltage U_B ⁴⁾ 10 ... 30VDC (incl. residual ripple)
 Residual ripple ≤ 15% of U_B
 Open-circuit current ≤ 20mA
 Switching output ⁵⁾ .../66 2 push-pull switching outputs
 .../66.1 pin 2: PNP dark switching, NPN light switching
 .../44 pin 4: PNP light switching, NPN dark switching
 Pin 2: PNP dark switching
 pin 4: PNP light switching
 IPRK.../4 1 PNP switching output light switching, 1 warning output
 PRK.../4 1 PNP switching output light switching, pin 2: not connected
 .../4.8 1 PNP switching output light switching, 1 activation input
 light/dark switching
 Signal voltage high/low ≥ ($U_B - 2V$) ≤ 2V
 Output current max. 100mA
 Operating range fixed setting, adjustable with potentiometer for ".1 types"

Function characteristics
 Signal voltage high/low
 Output current
 Operating range

Indicators

Green LED ready
 Yellow LED light path free
 Yellow LED, flashing light path free, no performance reserve

Mechanical data

Housing plastic (PC-ABS)
 Optics cover plastic (PMMA)
 Weight with connector: 15g
 with 200mm cable and connector: 30g
 with 2m cable: 55g
 cable 2m/5m (cross section 4x0.21 mm²),
 connector M8 or M12,
 cable 0.2m with connector M8 or M12

Connection type

Environmental data

Ambient temp. (operation/storage) ⁶⁾ -30°C ... +55°C/-30°C ... +60°C
 Protective circuit ⁷⁾ 2, 3
 VDE safety class ⁸⁾ II
 Protection class IP 66, IP 67
 Light source free group (in accordance with EN 62471)
 Standards applied IEC 60947-5-2
 Certifications UL 508, C22.2 No.14-13 ⁴⁾ ⁶⁾ ⁹⁾

Options

Warning output autoControl warn PNP transistor, counting principle
 Signal voltage high/low ≥ ($U_B - 2V$) ≤ 2V
 Output current max. 100mA
Activation input activ
 Transmitter active/not active ≥ 8V/≤ 2V
 Activation/disable delay ≤ 1ms
 Input resistance 10KΩ ± 10%

- 1) Typ. operating range limit: max. attainable range without performance reserve
- 2) Operating range: recommended range with performance reserve
- 3) Average life expectancy 100,000h at an ambient temperature of 25°C
- 4) For UL applications: for use in class 2 circuits according to NEC only
- 5) The push-pull switching outputs must not be connected in parallel
- 6) UL certified in the temperature range -30°C to 60°C
- 7) 2=polarity reversal protection, 3=short-circuit protection for all transistor outputs
- 8) Rating voltage 50V
- 9) These proximity switches shall be used with UL Listed Cable assemblies rated 30V, 0.5A min, in the field installation, or equivalent (categories: CYJV/CYJV7 or PVVA/PVVA7)

Tables

Reflectors		Operating range	
1	TK(S) 100x100	0.05 ... 8.0m	
2	TK(S) 40x60	0.05 ... 4.0m	
3	TK(S) 20x40	0.05 ... 2.5m	
1	0,05	8	10
2	0,05	4	5
3	0,05	2,5	3

□ Operating range [m]
 □ Typ. operating range limit [m]

TK ... = adhesive
 TKS ... = screw type

Diagrams

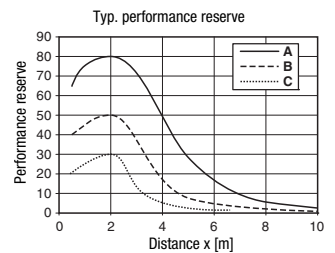
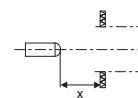
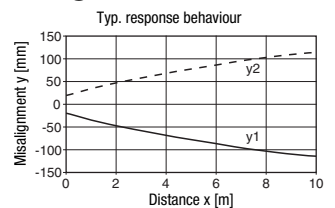

- A TK(S) 100x100
- B TK(S) 40x60
- C TK(S) 20x40

Remarks

Operate in accordance with intended use!

- ⚠ This product is not a safety sensor and is not intended as personnel protection.
- ⚠ The product may only be put into operation by competent persons.
- ⚠ Only use the product in accordance with the intended use.

UL REQUIREMENTS

Enclosure Type Rating: Type 1

For Use in NFPA 79 Applications only.

Adapters providing field wiring means are available from the manufacturer. Refer to manufacturers information.

CAUTION – the use of controls or adjustments or performance of procedures other than those specified herein may result in hazardous radiation exposure.

ATTENTION ! Si d'autres dispositifs d'alignement que ceux préconisés ici sont utilisés ou s'il est procédé autrement qu'indiqué, cela peut entraîner une exposition à des rayonnements et un danger pour les personnes.

PRK 25B
Retro-reflective photoelectric sensors with polarisation filter
Order guide

Selection table		PRK 25B/66-S12 Part No. 50104223	PRK 25B/66-S8 Part No. 50104224	PRK 25B/66 Part No. 50104225	PRK 25B/66,5000 Part No. 50133395	PRK 25B/66, 200-S12 Part No. 50104226	PRK 25B/4,8-S12 Part No. 50104227	IPRK 25B/4-S12 Part No. 50104228	IPRK 25B/4, 200-S12 Part No. 50104229	PRK 25B/66,1-S12 Part No. 50104230	PRK 25B/44-S12 Part No. 50109432	PRK 25B/4, 200-S8,1 Part No. 50113771
Equipment ↓		Order code →										
Switching output	2 x Push-pull switching output	●	●	●	●	●				●		
	1 x PNP output						●					●
	2 x PNP output							●	●		●	
Switching function	1 PNP light switching and NPN dark switching output	●	●	●	●	●				●		
	1 PNP dark switching and NPN light switching output	●	●	●	●	●				●		
	1 x PNP dark switching output										●	
	1 x PNP light switching output						●	●	●		●	●
	1 warning output							●	●			
Connection	M8 connector, 4-pin		●									
	M12 connector, 4-pin	●					●	●		●	●	
	cable 2.000mm			●								
	cable 5.000mm				●							
	cable 200mm with M12 connector, 4-pin					●			●			
	cable 200mm with M8 snap-in connector, 4-pin											●
Indicators	green LED: ready	●	●	●	●	●	●	●	●	●	●	●
	yellow LED: light path free	●	●	●	●	●	●	●	●	●	●	●
Options	operating range adjustment via potentiometer									●		
	activation input						●					
	high performance reserve	●	●	●	●	●	●	●	●	●	●	●

