

ifm electronic



Operating instructions  
Optical distance sensor

**efector200<sup>®</sup>**

**O1D102**

**UK**

706142 / 00 08 / 2012

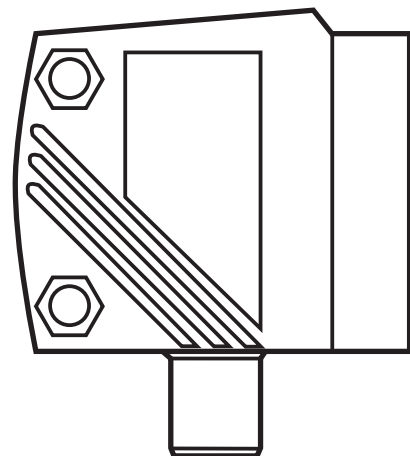

# Contents

1 Preliminary note.....	4
1.1 Symbols used.....	4
1.2 Warning signs used.....	4
2 Safety instructions.....	4
3 Functions and features.....	6
3.1 Applications.....	6
4 Functions.....	6
4.1 Output function hysteresis.....	6
4.2 Output function window.....	6
4.3 Analogue output function.....	6
5 Installation.....	7
5.1 Installation conditions.....	7
5.2 Mounting accessories.....	7
6 Electrical connection.....	8
7 Operating and display elements.....	9
8 Menu.....	10
8.1 Menu structure.....	10
8.2 Explanation of the menu.....	11
9 Operating modes.....	13
9.1 Run mode.....	13
9.2 Display mode.....	13
9.3 Align mode.....	13
9.4 Programming mode.....	13
10.Parameter setting.....	14
10.1 Parameter setting in general.....	14
10.1.1 Setting of the parameter value.....	14
10.1.2 Change from menu level 1 to menu level 2.....	15
10.1.3 Electronic lock.....	15
10.2 Configuration of the basic settings.....	16
10.2.1 Selection of the display unit.....	16
10.2.2 Setting of the display.....	16
10.2.3 Configuration of OUT1.....	16

10.2.4 Hysteresis function .....	17
10.2.5 Setting of the switch point for hysteresis function OUT1 .....	18
10.2.6 Window function .....	18
10.2.7 Setting of the switch points for window function OUT1 .....	19
10.2.8 Configuration of OUT2 .....	20
10.2.9 Setting of the switch point for hysteresis function OUT2 .....	20
10.2.10 Setting of the switch points for window function OUT2 .....	20
10.2.11 Scaling of the measuring range (analogue output).....	20
10.3 Teach mode .....	22
10.3.1 Setting of the sampling rate.....	22
10.3.2 Setting of the repeatability .....	22
10.3.3 Table repeatability and accuracy .....	22
10.4 Extended functions .....	23
10.4.1 Setting of the time delay for switching outputs .....	23
10.4.2 Setting of the damping of the measured signal .....	23
10.4.3 Reset of all parameters to factory setting .....	24
10.4.4 Display of the software version number .....	24
11 Set-up / operation .....	24
11.1 Fault indication.....	24
12 Maintenance, repair and disposal.....	25
13 Scale drawing .....	26
14 Factory setting .....	27

# 1 Preliminary note

## 1.1 Symbols used

▶ Instruction

> Reaction, result

[...] Designation of pushbuttons, buttons or indications

→ Cross-reference



Important note

Non-compliance can result in malfunctions or interference.



Information

Supplementary note.

## 1.2 Warning signs used



### **WARNING**

Warning of serious personal injury.

Death or serious irreversible injuries may result.

## 2 Safety instructions

- Please read this document prior to set-up of the unit. Ensure that the product is suitable for your application without any restrictions.
- Improper or non-intended use may lead to malfunctions of the unit or to unwanted effects in your application. That is why installation, electrical connection, set-up, operation and maintenance of the unit must only be carried out by qualified personnel authorised by the machine operator.
- In case of malfunction of the unit please contact the manufacturer. If the unit is tampered with and/or modified, any liability and warranty is excluded.

## **WARNING**

Visible laser light; laser protection class 2.

Use of controls or adjustments other than those specified herein may result in hazardous radiation exposure. Damage to the retina is possible.

- ▶ Do not stare into the laser beam!
- ▶ Apply the enclosed labels (laser warning) in the immediate vicinity of the unit.
- ▶ Adhere to the caution and warning notes on the product label.
- ▶ Use the enclosed label for the power supply cable.

## Label for supply cable

**ATTACH TO CABLE**



**WARNING:**

**CLASS 2 LASER PRODUCT**  
**DO NOT STARE INTO BEAM**  
- AVOID EXPOSURE  
- UNPLUG CONNECTOR TO  
EXTINGUISH LASER BEAM

ifm electronic gmbh D-45127 ESSEN

## Product label



AVOID EXPOSURE  
LASER LIGHT EMITTED  
FROM THIS APERTURE



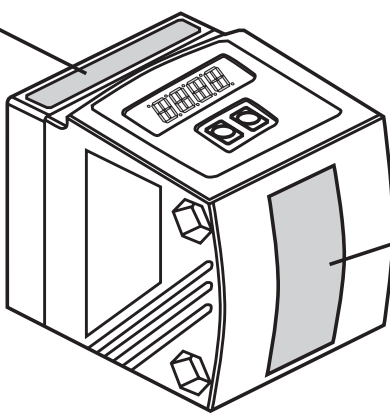



**CAUTION**  
LASER LIGHT  
DO NOT STARE INTO  
BEAM  
CLASS 2 LASER  
PRODUCT

max POWER 4.1 mW  
WAVELENGTH 650 nm  
PULSE 1.3 ns

21 CFR PART 1040  
EN60825-1:2003-10

UK

## 3 Functions and features

The unit is used as an optical distance sensor.

### 3.1 Applications

- The optical distance sensor measures distances between 0.2 and 3.5 m.
- It has a background suppression at > 3.5...4 m.
- The measured value is shown in a 10-segment display.
- According to the set output functions 2 output signals can be generated.



The distance between the sensor and the background must be limited to max. 4 m by the customer. Otherwise the measured value may be ambiguous. → 5.1 Installation conditions

## 4 Functions

### 4.1 Output function hysteresis

The hysteresis keeps the switching state of the output stable if the measured value varies about the sensing range. Both outputs (OUT1 and OUT2) can be set as hysteresis function. → 10.2.4 Hysteresis function

### 4.2 Output function window

The window function enables the monitoring of a defined acceptable range. Both outputs (OUT1 and OUT2) can be set as window function.

→ 10.2.6 Window function

### 4.3 Analogue output function

The sensor can also output an analogue signal on output 2 (OUT2) which is proportional to the distance. → 10.2.11 Scaling of the measuring range (analogue output).

# 5 Installation

## 5.1 Installation conditions

- ▶ Install the unit so that the object to be detected is within a measuring range of 0.2...3.5 m.

The unambiguity range of the sensor is fixed to 4 m. Objects within a range > 3.5...4 m are suppressed.

-  Reflecting objects in the direct beam path of the sensor - also in the range > 4 m – are to be avoided by the customer. Otherwise the measured values may be ambiguous.

UK

## 5.2 Mounting accessories

The unit is supplied without mounting accessories.

Examples of mounting accessories	Art. no.
Protective cover O1D	E21133
Mounting set E2D101 + E20938 + E20951	E21079
Mounting set O1D (for rod mounting Ø 12 mm)	E2D101
Mounting rod straight Ø 12 mm / M10	E20938
Mounting set O1D (for rod mounting Ø 14 mm)	E2D111
Mounting rod straight Ø 14 mm / M12	E20939
Fixture for mounting and fine adjustment of O1D laser units (rod or free-standing; depending on the clamp)	E1D100

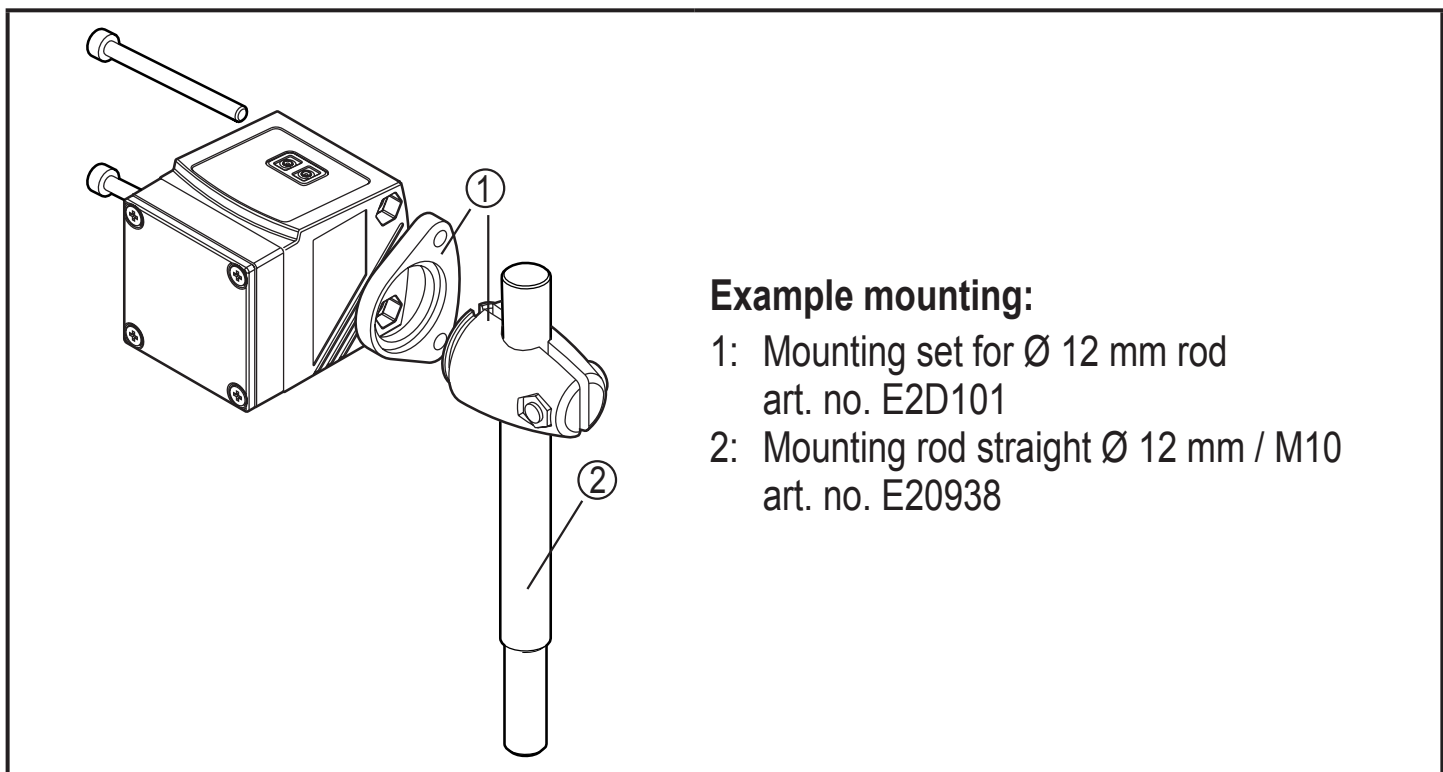

## 6 Electrical connection



The unit must be connected by a qualified electrician.

- ▶ The national and international regulations for the installation of electrical equipment must be adhered to.
- ▶ Ensure voltage supply according to EN 50178, SELV, PELV.

▶ Disconnect power.

▶ Connect the unit as follows:

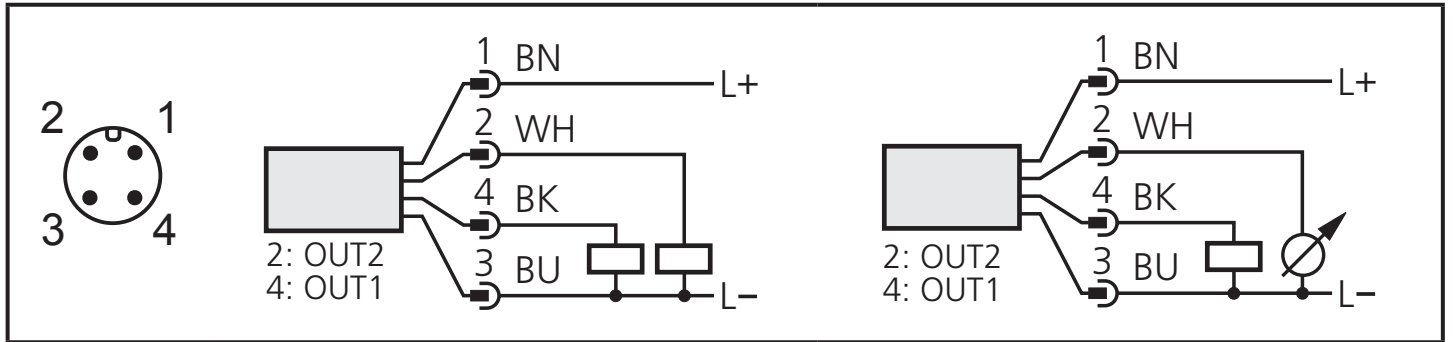

Core colours of ifm sockets:

1 = BN (brown), 2 = WH (white), 3 = BU (blue), 4 = BK (black)



## 7 Operating and display elements

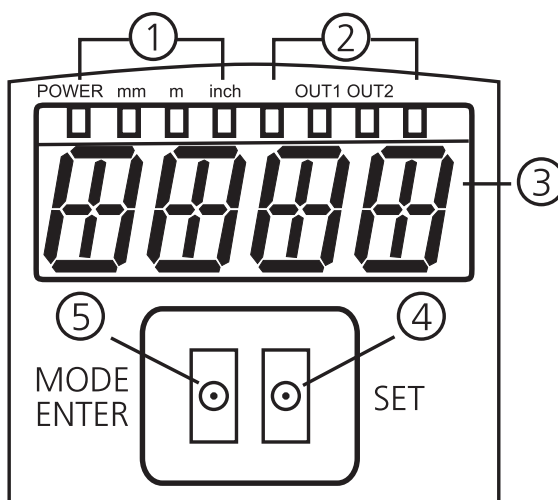

1: 4 x LED green	Lighting LED = power and set display unit (mm, m, inch)
2: 4 x LED yellow (two not connected)	Indication of the switching status; lights, if the corresponding output is switched.
3: 4-digit alphanumeric display	Indication of the measured distance, the parameters and parameter values.
4: Programming button [SET]	Setting of the parameter values (scrolling by holding pressed; incrementally by pressing once).
5: Programming button [MODE/ENTER]	Selection of the parameters and acknowledgement of the parameter values.



## 8.2 Explanation of the menu

For the factory settings please refer to the end of these instructions  
(→ 14 Factory setting).

<i>OU 1</i>	<p><b>Configuration for output 1</b> 4 switching functions can be selected: [Hno], [Hnc], [Fno], [Fnc] → 10.2.3 Configuration of OUT1</p>
<i>SP 1</i>	<p><b>Switch point for hysteresis function OUT1</b> Limit value at which the output with selected hysteresis function changes its switching state (object nearer/farther than distance set). [SP1] is only active if [OU1] = [Hno] or [Hnc]. → 10.2.5 Setting of the switch point for hysteresis function OUT1</p>
<i>nSP 1</i> <i>FSP 1</i>	<p><b>Switch points for window function OUT1</b> Limit values at which the output with selected window function changes its switching state (object present / not present between the distance "near" and the distance "far"). [nSP1] = switch point "near" / [FSP1] = switch point "far". [nSP1] / [FSP1] are only active if [OU1] = [Fno] or [Fnc]. → 10.2.7 Setting of the switch points for window function OUT1</p>
<i>OU2</i>	<p><b>Configuration for output 2</b> 4 switching functions and 2 analogue signals can be selected: [Hno], [Hnc], [Fno], [Fnc], [I], [U] → 10.2.8 Configuration of OUT2</p>
<i>SP2</i>	<p><b>Switch point for hysteresis function OUT2</b> Limit value at which the output with selected hysteresis function changes its switching state (object nearer/farther than distance set). [SP2] is only active if [OU2] = [Hno] or [Hnc]. → 10.2.9 Setting of the switch point for hysteresis function OUT2</p>
<i>nSP2</i> <i>FSP2</i>	<p><b>Switch points for window function OUT2</b> Limit values at which the output with selected window function changes its switching state (object present / not present between the distance "near" and the distance "far"). [nSP2] = switch point "near" / [FSP2] = switch point "far". [nSP2] / [FSP2] are only active if [OU2] = [Fno] or [Fnc]. → 10.2.10 Setting of the switch points for window function OUT2</p>
<i>ASP</i>	<p><b>Analogue start point</b> Measured value at which 4 mA / 0 V are provided. [ASP] is only active if [OU2] = [I] or [U]. → 10.2.11 Scaling of the measuring range (analogue output)</p>

<b>AEP</b>	<p><b>Analogue end point</b>  Measured value at which 20 mA / 10 V are provided.  [AEP] is only active if [OU2] = [I] or [U].  → 10.2.11 Scaling of the measuring range (analogue output)</p>
<b>TEAC</b>	<p><b>Teach mode</b>  Selection "sampling rate" or "repeatability"  → 10.3 Teach mode</p>
<b>EF</b>	<p><b>Extended functions</b>  Press [SET] to open the submenu "Extended functions"  → 10.4 Extended functions</p>
<b>dS 1</b> <b>dr 1</b> <b>dS2</b> <b>dr 2</b>	<p><b>Delay for the switching outputs</b>  [dSx] = switch-on delay; [drx] = switch-off delay.  The output does not immediately change its switching status when the switching condition is met but only after the delay has elapsed. If the switching condition is no longer met after the delay has elapsed, the switching status of the output does not change.  [dS2] and [dr2] are not effective if [OU2] = [I] or [U].  → 10.4.1 Setting of the time delay for switching outputs</p>
<b>dAP</b>	<p><b>Damping of the measured signal</b>  This function allows to suppress short-time saturation of the measuring element (such saturation can result from direct reflection or strong fluctuations in brightness).  During the delay set, the latest valid value measured is displayed, the output signals remain unchanged.  → 10.4.2 Setting of the damping of the measured value</p>
<b>d 5</b>	<p><b>Display setting</b>  7 settings can be selected:  [d1], [d2], [d3], [rd1], [rd2], [rd3], [OFF]  → 10.2.2 Setting of the display</p>
<b>U<sub>mi</sub></b>	<p><b>Setting of the display unit</b>  Selection of the unit of measurement for [SP1], [SP2], [ASP], [AEP]  Selection options: [mm] [m] [inch]  → 10.2.1 Selection of the display unit</p>
<b>r-ES</b>	<p><b>Restore factory setting</b>  → 10.4.3 Reset of all parameters to factory setting</p>
<b>SW</b>	<p><b>Display of the software version number</b>  → 10.4.4 Display of the software version number</p>

## 9 Operating modes

### 9.1 Run mode

The run mode is the normal operating mode.

After power on the unit is in the Run mode. It carries out its monitoring function and generates output signals according to the set parameters.

The display indicates the current distance, the yellow LEDs signal the switching status of the outputs.

### 9.2 Display mode

Indication of the parameters and the set parameter values.

- ▶ Press [MODE/ENTER] briefly.
- > Unit goes to the Display mode. Internally it remains in the operating mode. The set parameter values can be read.
- ▶ To scroll through the parameters, press [MODE/ENTER] briefly.
- ▶ To display the respective parameter value, press [SET] briefly.
- > After 15 s the unit returns to the Run mode.

### 9.3 Align mode

Display of the orientation value for the signal strength.

- ▶ Press [SET] in the Run mode.
- > The unit displays an orientation value for the signal strength (+100 corresponds to a white object, +020 corresponds to a grey object).

### 9.4 Programming mode

Setting the parameter values → 10.1 Parameter setting in general

# 10. Parameter setting

During parameter setting the unit remains internally in the operating mode. It continues its monitoring function with the existing parameters until the change has been finished.

## 10.1 Parameter setting in general

### 10.1.1 Setting of the parameter value



Select the display unit [Uni] before you define the values for the parameters. In case of subsequent changes of the display unit rounding errors during internal conversion to other units may falsify the set values.

→ 10.2.1 Selection of the display unit

1	<p><b>Selection of the parameter</b></p> <ul style="list-style-type: none"> <li>▶ Press [MODE/ENTER] until the requested parameter is displayed.</li> </ul>	
2	<p><b>Setting of the parameter value</b></p> <ul style="list-style-type: none"> <li>▶ Press [SET] and keep it pressed.</li> <li>&gt; The current parameter value flashes for 5 s.</li> <li>▶ Increase the setting value incrementally by pressing the button once or continuously by pressing it permanently.</li> </ul>	
<p>Decrease the value: let the display move to the maximum setting value. Then the cycle starts again at the minimum setting value.</p>		
3	<p><b>Confirmation of the parameter value</b></p> <ul style="list-style-type: none"> <li>▶ Press [MODE/ENTER] briefly.</li> <li>&gt; The parameter is displayed again; the new parameter value is effective.</li> </ul>	
4	<p><b>Setting of other parameters</b></p> <ul style="list-style-type: none"> <li>▶ Start again with step 1.</li> </ul>	
5	<p><b>Finishing the parameter setting</b></p> <ul style="list-style-type: none"> <li>▶ Wait for 15 s or press [MODE/ENTER].</li> <li>&gt; The current measured value is displayed.</li> </ul>	

## 10.1.2 Change from menu level 1 to menu level 2

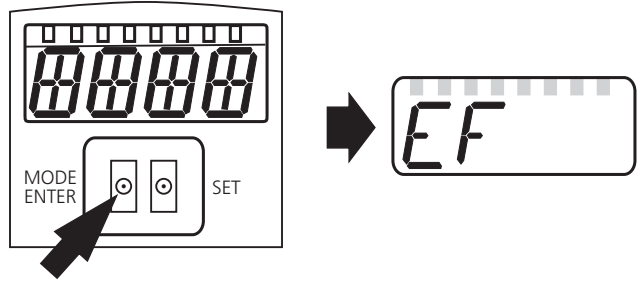
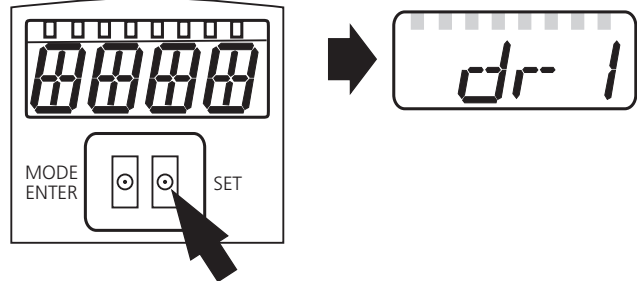
<ul style="list-style-type: none"> <li>▶ Press [MODE/ENTER] several times until [EF] is displayed.</li> </ul>	
<ul style="list-style-type: none"> <li>▶ Press [SET] briefly.</li> <li>&gt; The first parameter of the sub-menu is displayed (here: [dr1]).</li> </ul>	

UK

## 10.1.3 Electronic lock

The unit can be locked electronically to prevent unintentional settings. On delivery the unit is not locked.

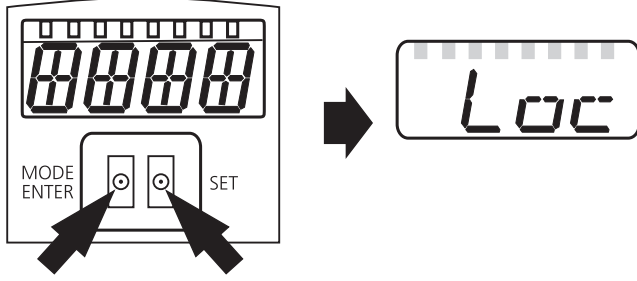
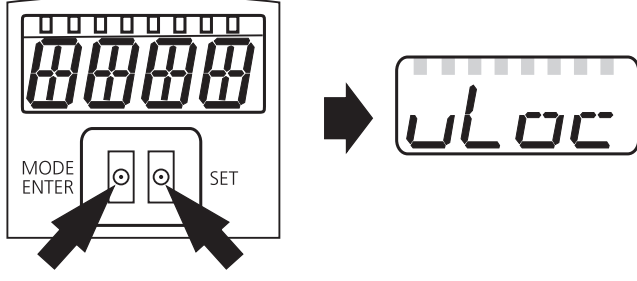
<p><b>Locking</b></p> <ul style="list-style-type: none"> <li>▶ Make sure that the unit is in the normal operating mode.</li> <li>▶ Keep [MODE/ENTER] + [SET] pressed until [Loc] is displayed.</li> <li>&gt; The unit is locked.</li> </ul>	
<p>[Loc] is displayed briefly if you try to change parameter values on the locked unit during operation.</p>	
<p><b>Unlocking</b></p> <ul style="list-style-type: none"> <li>▶ Keep [MODE/ENTER] + [SET] pressed until [uLoc] is displayed.</li> <li>&gt; The unit is unlocked.</li> </ul>	

### Timeout:



If no button is pressed for 15 s during the setting procedure, the unit returns to the Run mode with unchanged values.

## 10.2 Configuration of the basic settings

### 10.2.1 Selection of the display unit

<p>Set [Uni] before the values for the parameters [SPx], [nSPx], [FSPx], [ASP], [AEP] are defined.</p> <p>In case of subsequent changes of the display unit rounding errors during internal conversion to other units may falsify the set values.</p> <ul style="list-style-type: none"><li>▶ Change to [EF].</li><li>▶ Select [Uni] and set the unit of measurement. Selection of the unit of measurement: [mm], [m], [inch]</li><li>▶ Confirm with [MODE/ENTER].</li></ul> <p>&gt; The selected unit is indicated by a green LED on the display.</p>	
--	--

### 10.2.2 Setting of the display

<ul style="list-style-type: none"><li>▶ Change to [EF].</li><li>▶ Select [diS] and make the settings. 7 settings can be selected:<ul style="list-style-type: none"><li>• [d1] = update of the measured value every 50 ms.</li><li>• [d2] = update of the measured value every 200 ms.</li><li>• [d3] = update of the measured value every 600 ms.</li><li>• [rd1], [rd2], [rd3] = display like [d1], [d2], [d3] rotated by 180°. The update of the measured value only refers to the display. It has no effect on the outputs.</li><li>• [OFF] = The measured value display is deactivated in the Run mode. Press one button to indicate the current measured value for 15 s.</li></ul></li><li>▶ Confirm with [MODE/ENTER].</li></ul> <p>The LEDs remain active even if the display is deactivated.</p>	
--	--

### 10.2.3 Configuration of OUT1

<ul style="list-style-type: none"><li>▶ Select [OU1] and set the switching functions. Switching functions:<ul style="list-style-type: none"><li>• [Hno] = hysteresis function / normally open</li><li>• [Hnc] = hysteresis function / normally closed</li><li>• [Fno] = window function / normally open</li><li>• [Fnc] = window function / normally closed</li></ul></li><li>▶ Confirm with [MODE/ENTER].</li></ul>	
--	--



## 10.2.4 Hysteresis function

The hysteresis keeps the switching state of the output stable if the measured value varies about the sensing range. In either case set and reset points are symmetrically arranged around the selected switch point  $[SPx]$ . The hysteresis is the distance between set and reset points; it is calculated on the basis of the repeatability with a safety factor of 1.5. → 10.3.3 Table repeatability and accuracy

### Example Hno

1. For the output function  $[Hno]$  the output switches when the object approaches and when the switch point (A) is reached.
2. When the object is removed again, the output does not switch back before the reset point (B) is exceeded.  
The reset point (B) is greater than the set point (A).

UK

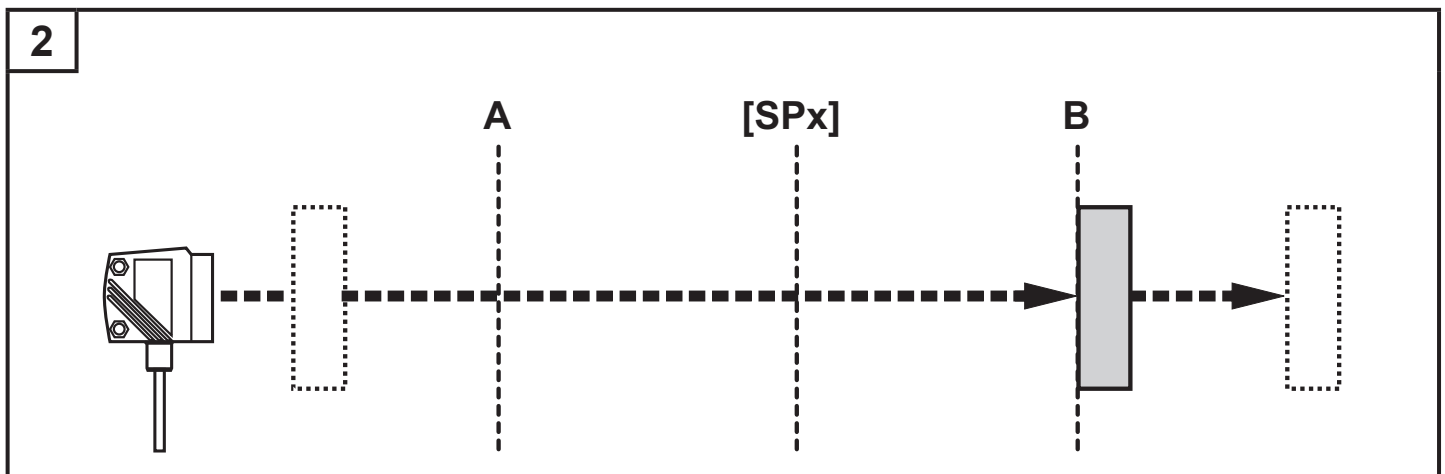
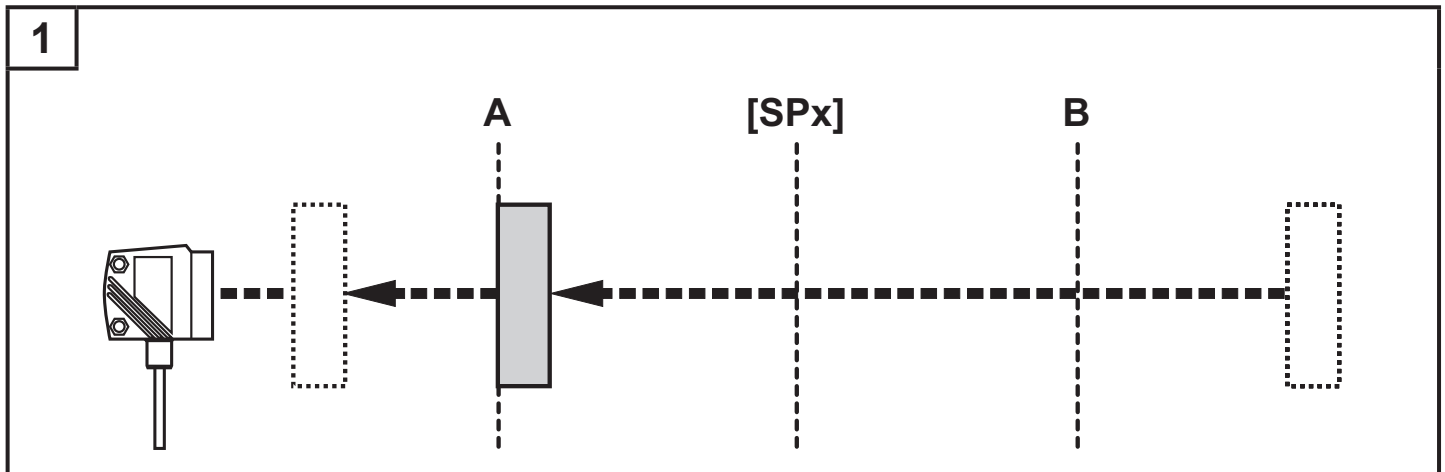

$[SPx]$  = switch point; A = set point; B = reset point

When the output function  $[Hnc]$  was selected, set and reset point are reversed. The output is switched off when the object approaches. When the object is removed, the output switches on.

## Switching status of the outputs

Output function	Object distance (D)	Output status
[Hno]	$D < [SPx]$	Closed
	$D > [SPx]$	Open
[Hnc]	$D < [SPx]$	Open
	$D > [SPx]$	Closed

### Example of output function [Hno]

Sampling rate 5 Hz, distance to the object 1200 mm, grey value (18 % remission):

Hysteresis =  $\pm 9.5$  mm (repeatability  $\rightarrow$  10.3.3 table) x factor 1.5 = 14 mm

- Reset point 1200 mm + (14 mm) = 1214 mm

- Set point 1200 mm - (14 mm) = 1186 mm

## 10.2.5 Setting of the switch point for hysteresis function OUT1

<ul style="list-style-type: none"> <li>▶ Select the output function [Hno] or [Hnc] at [OU1].</li> <li>▶ Confirm with [MODE/ENTER].</li> <li>▶ Select [SP1] and set the switch point.</li> <li>▶ Confirm with [MODE/ENTER].</li> </ul>	
---	--

## 10.2.6 Window function

It is possible to define a window for the object recognition for each of the two outputs (OUT1 / OUT2).

### Switches off when the object is detected

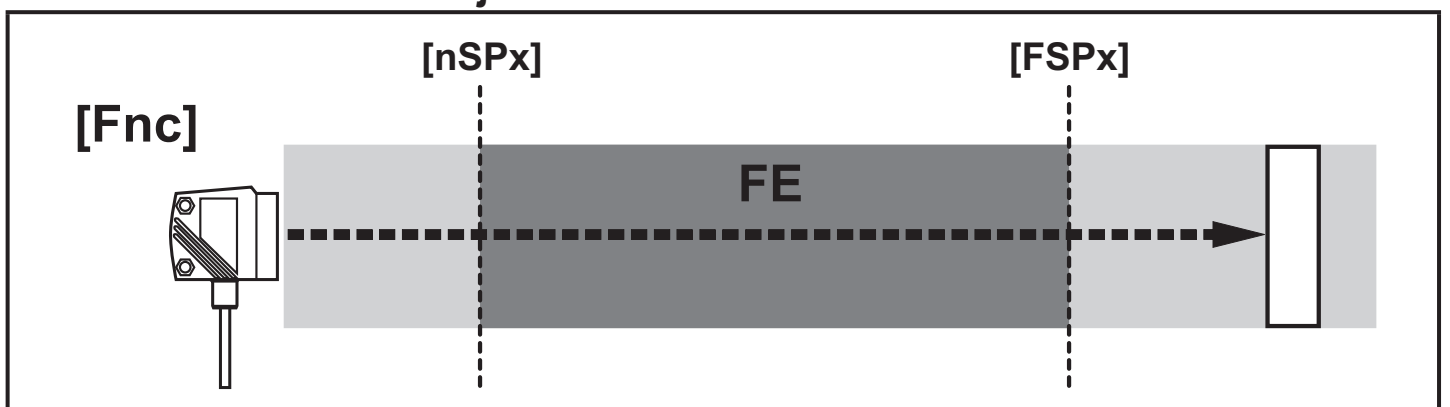

[nSPx] = switch point "near"; [FSPx] = switch point "far"; FE = window

If the measured value is between the switch point "near" [nSPx] and the switch point "far" [FSPx], the output is open (when [OUx] = [Fnc]).

## Switches when the object is detected

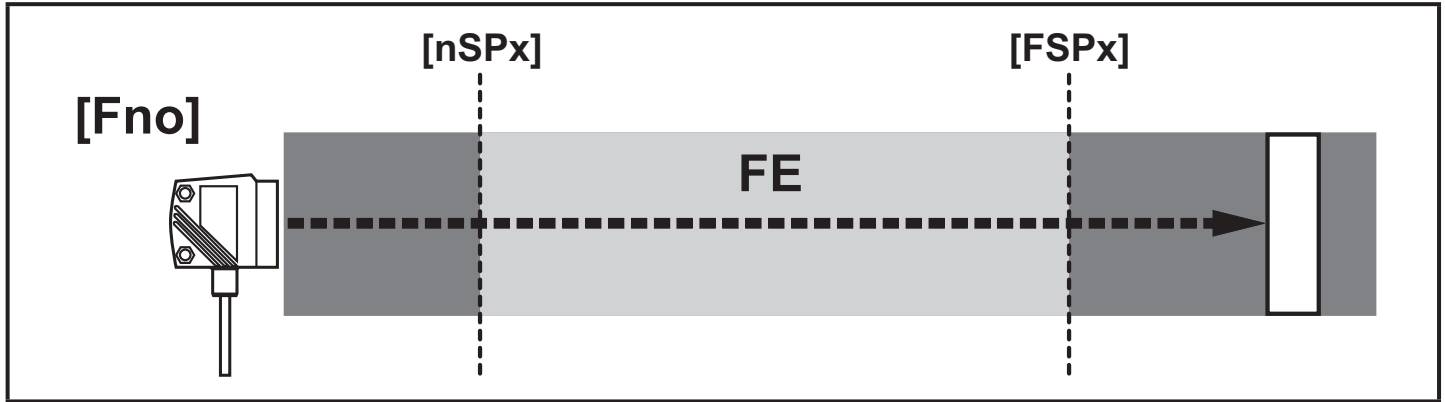

[nSPx] = switch point "near"; [FSPx] = switch point "far"; FE = window

If the measured value is between the switch point "near" [nSPx] and the switch point "far" [FSPx], the output is closed (when [OUx] = [Fno]).

UK

## Switching status of the outputs

Output function	Object distance (D)	Output status
[Fno]	D < [nSPx] D > [FSPx]	Open
	[nSPx] < D < [FSPx]	Closed
[Fnc]	D < [nSPx] D > [FSPx]	Closed
	[nSPx] < D < [FSPx]	Open

Both window limit values ([nSPx] and [FSPx]) work with a switching hysteresis  
 → 10.2.4 Hysteresis function / example of the output function [Hno].

## 10.2.7 Setting of the switch points for window function OUT1

<ul style="list-style-type: none"> <li>▶ Select the output function [Fno] or [Fnc] at [OU1].</li> <li>▶ Confirm with [MODE/ENTER].</li> <li>▶ Select [nSP1] and set the switch point "near".</li> <li>▶ Confirm with [MODE/ENTER].</li> <li>▶ Select [FSP1] and set the switch point "far".</li> <li>▶ Confirm with [MODE/ENTER].</li> </ul>	<p>OU 1</p> <p>nSP 1</p> <p>FSP 1</p>
--	---------------------------------------

## 10.2.8 Configuration of OUT2

<ul style="list-style-type: none"> <li>▶ Select [OU2].</li> <li>▶ Set the switching functions or analogue signals:             <ul style="list-style-type: none"> <li>• [Hno] = hysteresis function / normally open</li> <li>• [Hnc] = hysteresis function / normally closed</li> <li>• [Fno] = window function / normally open</li> <li>• [Fnc] = window function / normally closed</li> <li>• [I] = current output analogue 4...20 mA</li> <li>• [U] = voltage output analogue 0...10 V</li> </ul> </li> <li>▶ Confirm with [MODE/ENTER].</li> </ul>	<p>OU2</p>
--	------------

## 10.2.9 Setting of the switch point for hysteresis function OUT2

<ul style="list-style-type: none"> <li>▶ Select [Hno] or [Hnc] at [OU2].</li> <li>▶ Confirm with [MODE/ENTER].</li> <li>▶ Select [SP2] and set the switch point.</li> <li>▶ Confirm with [MODE/ENTER].</li> </ul> <p>→ 10.2.4 Hysteresis function</p>	<p>OU2</p> <p>SP2</p>
---	-----------------------

## 10.2.10 Setting of the switch points for window function OUT2

<ul style="list-style-type: none"> <li>▶ Select [Fno] or [Fnc] at [OU2].</li> <li>▶ Confirm with [MODE/ENTER].</li> <li>▶ Select [nSP2] and set the switch point "near".</li> <li>▶ Confirm with [MODE/ENTER].</li> <li>▶ Select [FSP2] and set the switch point "far".</li> <li>▶ Confirm with [MODE/ENTER].</li> </ul> <p>→ 10.2.6 Window function</p>	<p>OU2</p> <p>nSP2</p> <p>FSP2</p>
--	------------------------------------

## 10.2.11 Scaling of the measuring range (analogue output)

<ul style="list-style-type: none"> <li>▶ Select [I] or [U] at [OU2].</li> <li>▶ Confirm with [MODE/ENTER].</li> <li>▶ Select [ASP] and set "Analogue start point". With [ASP] you define at which measured value the output signal is 4 mA / 0 V.</li> <li>▶ Confirm with [MODE/ENTER].</li> <li>▶ Select [AEP] and set the "Analogue end point". With [AEP] you define at which measured value the output signal is 20 mA / 10 V. It can also be selected so that it is before [ASP]. This implements a falling edge.</li> <li>▶ Confirm with [MODE/ENTER].</li> </ul> <p><b>Minimum distance between [ASP] and [AEP]:100 mm</b> When the minimum distance is not reached, the error message "SIZE" is displayed.</p>	<p>OU2</p> <p>ASP</p> <p>AEP</p>
--	----------------------------------

## Current output 4 ... 20 mA

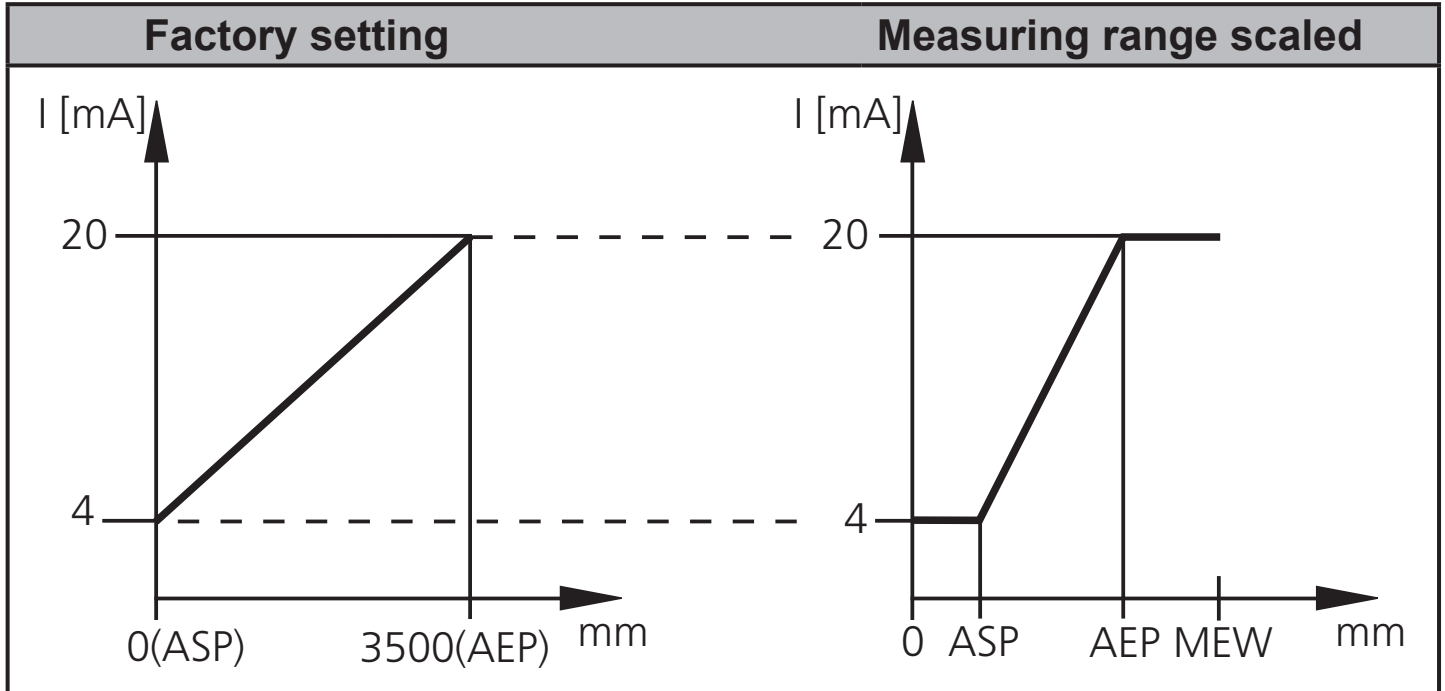

MEW = final value of the measuring range

In the set measuring range the output signal is between 4 and 20 mA.

Faults are also displayed:

Too much light or object too near: 3.5 mA for a rising edge ( $[ASP] < [AEP]$ ), 20.5 mA for a falling edge ( $[ASP] > [AEP]$ ).

Object too far or no object present:

20.5 mA for a rising edge; 3.5 mA for a falling edge.

## Voltage output 0 ... 10 V

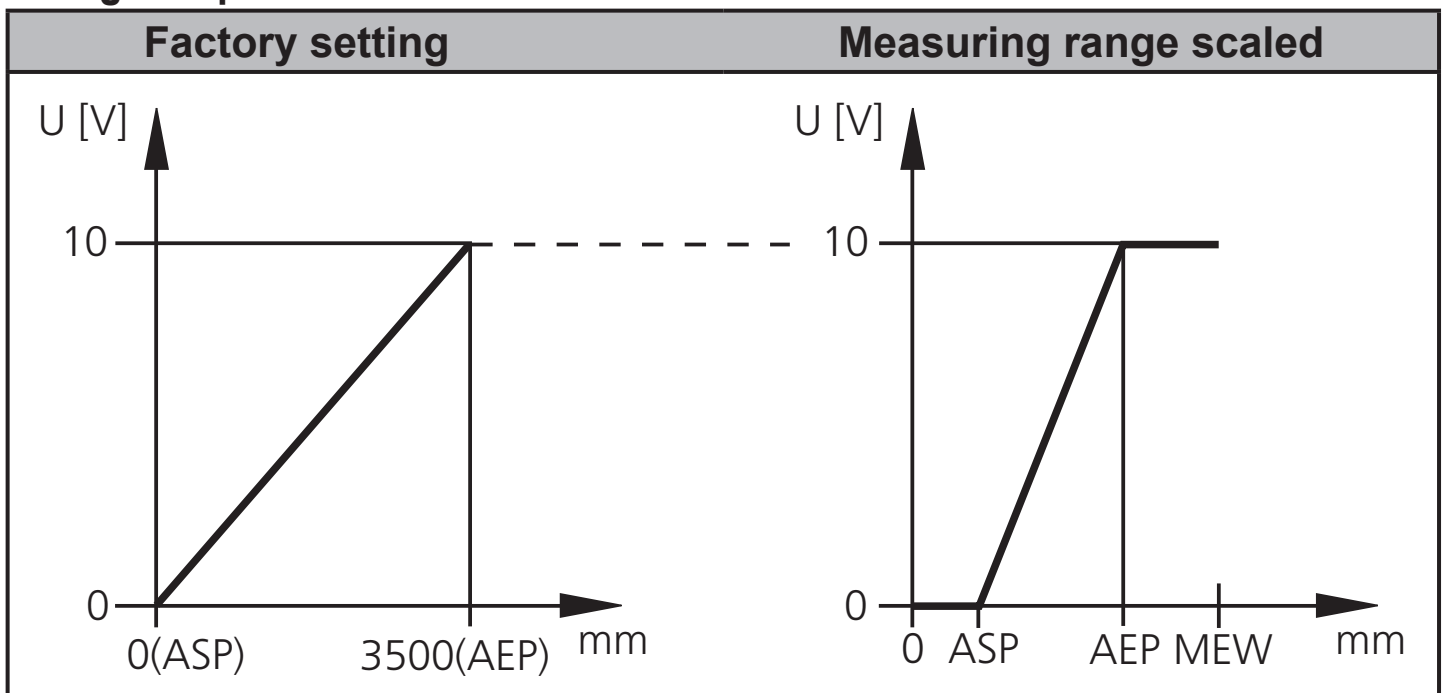

MEW = final value of the measuring range

In the set measuring range the output signal is between 0 and 10V.

UK

## 10.3 Teach mode

### 10.3.1 Setting of the sampling rate

<p>The sampling rate indicates the time after which a new result of measurement is provided and the outputs are updated. The switching frequency is typ. approx. 1/3 of the sampling rate.</p> <ul style="list-style-type: none"> <li>▶ Select [TEAC], then press [SET] and keep pressed until [WAIT] is displayed.</li> <li>&gt; [rATE] and [rEPr] are displayed alternately.</li> <li>▶ When [rATE] is displayed: Press [SET] until the preset measured sampling rate value flashes.</li> <li>▶ Enter a value incrementally by pressing [SET] once.</li> <li>▶ Confirm with [MODE/ENTER].</li> <li>&gt; [WAIT] is displayed while the repeatability [rEPr] is calculated.</li> <li>&gt; The sampling rate [rATE] and the repeatability [rEPr] are displayed alternately.</li> </ul>	<p><i>TEAC</i> <i>-ATE</i></p>
---	------------------------------------

### 10.3.2 Setting of the repeatability

<ul style="list-style-type: none"> <li>▶ Select [TEAC], then press [SET] and keep pressed until [WAIT] is displayed.</li> <li>&gt; [rATE] and [rEPr] are displayed alternately.</li> <li>▶ When [rEPr] is displayed: Press [SET] until the preset repeatability value flashes.</li> <li>▶ Enter value incrementally by pressing [SET] once.</li> <li>▶ Confirm with [MODE/ENTER].</li> <li>&gt; [WAIT] is displayed while the sampling rate [rATE] is calculated.</li> <li>&gt; The sampling rate [rATE] and the repeatability [rEPr] are displayed alternately.</li> </ul>	<p><i>TEAC</i> <i>-EPr-</i></p>
---	-------------------------------------

### 10.3.3 Table repeatability and accuracy

#### Values for sampling rate 5 Hz

Distance in [mm]	Repeatability		Accuracy	
	white 90 % remission	grey 18 % remission	white 90 % remission	grey 18 % remission
200...1000	± 6.5 mm	± 7.5 mm	± 32 mm	± 40 mm
1000...2000	± 8 mm	± 9.5 mm	± 33 mm	± 40 mm
2000...3000	± 17 mm	± 19 mm	± 42 mm	± 50 mm
3000...3500	± 23 mm	± 25 mm	± 50 mm	± 55 mm

The values apply at:

- constant ambient conditions (23°C / 960 hPa)
- extraneous light of max.: 100 klx
- only after unit powered up for 10 minutes

## 10.4 Extended functions

### 10.4.1 Setting of the time delay for switching outputs

<ul style="list-style-type: none"><li>▶ Select [EF].</li><li>▶ Press [SET] to change to the menu [EF].</li><li>▶ Select parameters with [MODE/ENTER]: [dSx] = switch-on delay; [drx] = switch-off delay</li><li>▶ Set the parameter value with [SET]: Setting range [s]: 0 / 0.1 ... 5 s in steps of 0.1s (0 = delay time is not active)</li><li>▶ Confirm with [MODE/ENTER].</li></ul>	<i>EF</i> <i>dS 1</i> <i>dr 1</i> <i>dS 2</i> <i>dr 2</i>
---	---

UK

### 10.4.2 Setting of the damping of the measured signal

<ul style="list-style-type: none"><li>▶ Select [EF].</li><li>▶ Press [SET] to change to the menu [EF].</li><li>▶ Select [dAP].</li><li>▶ Set the parameter value with [SET]: Setting range [s]: 0...0.1...0.2...0.5...1...2...5.</li><li>▶ Confirm with [MODE/ENTER].</li></ul>	<i>EF</i> <i>dAP</i>
---	-------------------------

### 10.4.3 Reset of all parameters to factory setting

<ul style="list-style-type: none"><li>▶ Select [EF].</li><li>▶ Press [SET] to change to the menu [EF].</li><li>▶ Select [rES], then press [SET] and keep it pressed until [----] is displayed.</li><li>▶ Confirm with [MODE/ENTER].</li><li>&gt; The unit changes to the Run mode.</li></ul>	<i>EF</i> <i>r-ES</i>
--	--------------------------

### 10.4.4 Display of the software version number

<ul style="list-style-type: none"><li>▶ Select [EF].</li><li>▶ Press [SET] to change to the menu [EF].</li><li>▶ Select [SW], then press [SET].</li><li>&gt; The software version number is displayed.</li><li>▶ Press [MODE/ENTER] to return to the menu [EF].</li></ul>	<i>EF</i> <i>SW</i>
---	------------------------

## 11 Set-up / operation

- ▶ After mounting, wiring and programming check whether the unit operates correctly.
- > If the unit has been correctly set up, the distance to the object is indicated.



Lifetime of a laser diode: 50000 hours

## 11.1 Fault indication

Display	Possible cause	Switching output				Current output / voltage output	
		[Hno]	[Hnc]	[Fno]	[Fnc]	[ASP] < [AEP]	[ASP] > [AEP]
[++]	too much light, e.g. reflective surface	ON	OFF	OFF	ON	3.5 mA / 0 V	20.5 mA / 10 V
[- -]	too little light, no object	OFF	ON	OFF	ON	20.5 mA / 10 V	3.5 mA / 0 V
[nEAr]	object to be measured outside the measuring range < 0.2 m	ON	OFF	OFF	ON	3.5 mA / 0 V	20.5 mA / 10 V
[FAr]	object to be measured outside the measuring range > 3.5 m	OFF	ON	OFF	ON	20.5 mA / 10 V	3.5 mA / 0 V
[Errp]	plausibility (e.g. object too fast)	X <sup>1)</sup>	X <sup>1)</sup>	X <sup>1)</sup>	X <sup>1)</sup>	X <sup>1)</sup>	X <sup>1)</sup>
[SC1]	short circuit in switching output 1					2)	2)
[SC2]	short circuit in switching output 2					2)	2)
[SC]	short circuit in all switching outputs						

<sup>1)</sup>unchanged

<sup>2)</sup>[SC1] or [SC] only active, if output 2 is configured as switching output.

## 12 Maintenance, repair and disposal

Faulty sensors must only be repaired by the manufacturer.

- ▶ Keep the front lens of the sensor free from soiling.
- ▶ After use dispose of the unit in an environmentally friendly way in accordance with the applicable national regulations.



# 13 Scale drawing

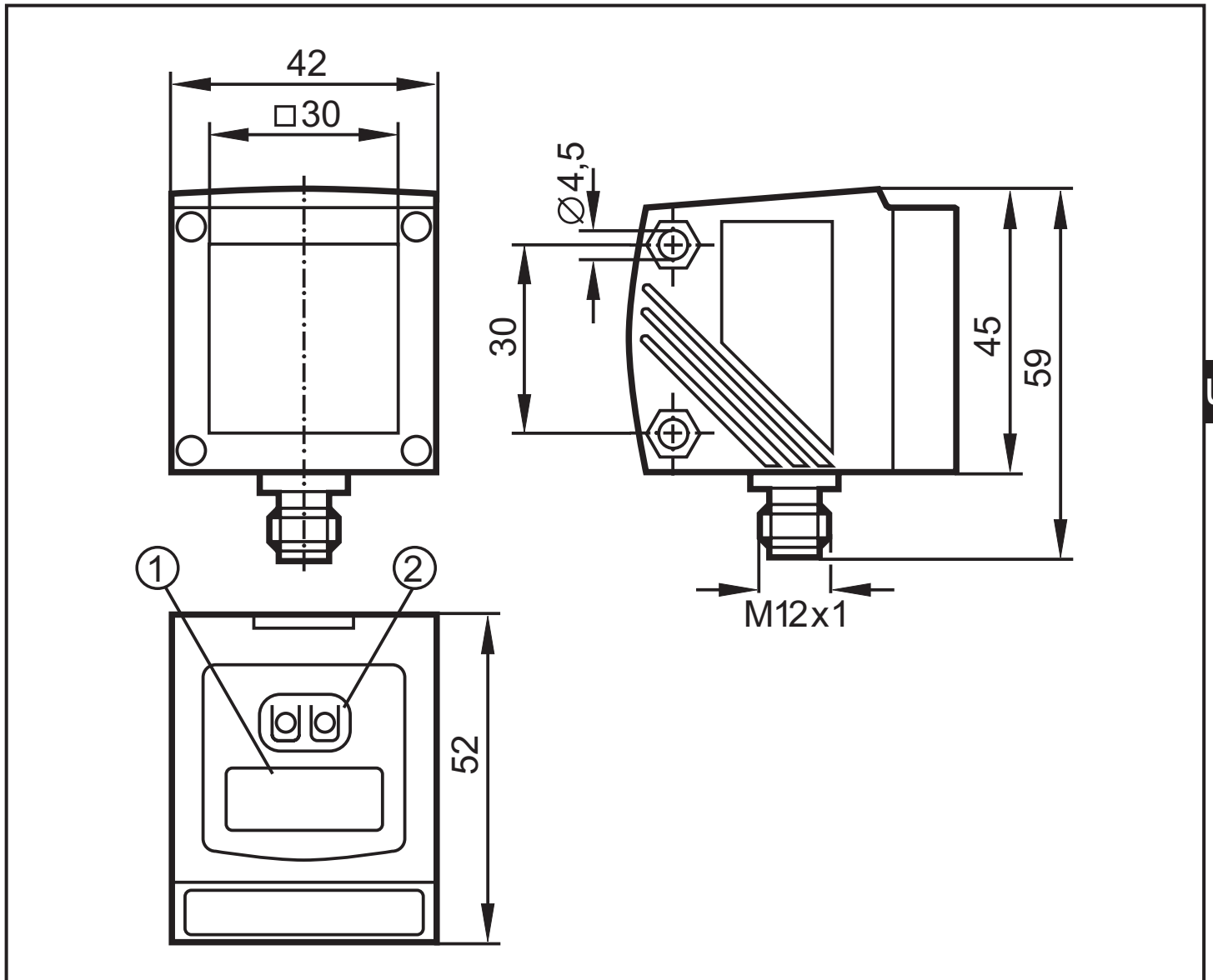

Dimensions in mm

- 1: 4-digit alphanumeric display / LED function display
- 2: programming buttons

## 14 Factory setting

Parameter	Setting range	Factory setting	Own setting
<b>Uni</b>	mm, m, inch	mm	
<b>OU1</b>	Hno, Hnc, Fno, Fnc	Hno	
<b>SP1</b>	200...3500	1000	
<b>nSP1</b>	200...3500	800	
<b>FSP1</b>	200...3500	1200	
<b>OU2</b>	Hno, Hnc, Fno, Fnc, I, U	I	
<b>SP2</b>	200...3500	2000	
<b>nSP2</b>	200...3500	1800	
<b>FSP2</b>	200...3500	2200	
<b>ASP</b>	0...3500	0	
<b>AEP</b>	0...3500	3500	
<b>rATE</b>	1...50	5 Hz	
<b>dS1</b>	0...0.1...5	0 s	
<b>dr1</b>	0...0.1...5	0 s	
<b>dS2</b>	0...0.1...5	0 s	
<b>dr2</b>	0...0.1...5	0 s	
<b>dAP</b>	0...0.1...0.2...0.5...1...2...5	0 s	
<b>diS</b>	d1...3; rd1...3; OFF	d3	

Technical data and further information at [www.ifm.com](http://www.ifm.com)

