

**MN501S**

MN44008-AKOG/6m/-H

Magnetsensor

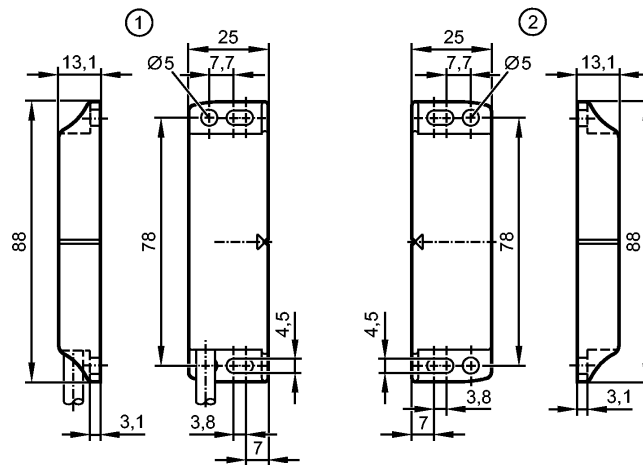

1: Sensor  
2: Codierter Betätiger



**Produktmerkmale**

Magnetisch codierter Sensor
Quaderförmig Kunststoff
Anschlussleitung
Codierter Betätiger
Schaltabstand (Sn) 8 mm; mit codiertem Betätiger; [nb] nicht bündig einbaubar
Entspricht den Anforderungen: EN ISO 13849-1: 2015 Kategorie 4 PL e (In Verbindung mit einer Auswerteeinheit vom Typ G150xS / AC42xS kann bis zu PL e (ISO13849-1) bzw. SIL cl 3 (IEC62061) erreicht werden) IEC 62061: SILcl 3

**Einsatzbereich**

Einsatzbereich	Für sicherheitstechnische Applikationen
Betriebsart	Dauerbetrieb

**Elektrische Daten**

Elektrische Ausführung	DC
Betriebsspannung [V]	24 DC
Bemessungsisolationsspannung [V]	120
Schutzklasse	III
Verpolungsschutz	nein
Innenwiderstand (Ri) [Ω]	10 (1 W)

**Ausgänge**

Ausgangsfunktion	2 x Schließer
Ausgangskenndaten	Interface Typ A
Spannungsabfall [V]	1
Strombelastbarkeit [mA]	50
Kurzschlussfest	nein
Schaltfrequenz [Hz]	150
Schaltleistung (max.) [W]	6
Max. kapazitive Last CL_max [nF]	20

**Erfassungsbereich**

Schaltabstand (Sn) [mm]	8, mit codiertem Betätiger
-------------------------	----------------------------

## MN501S

MN44008-AKOG/6m/-H

Magnetsensor

Gesicherter Ausschaltabstand s(ar)	[mm]	20
------------------------------------	------	----

### Reaktionszeiten

Reaktionszeit auf Sicherheitsanforderung	[ms]	10
Abfallzeit	[ms]	0,1
Schaltzeit inkl. Prellen	[ms]	0,6

### Umgebungsbedingungen

Einsatzort		Klasse C nach EN 60654-1 Wettergeschützter Einsatzort
Umgebungstemperatur	[°C]	-25...80, für Gebrauchsdauer ≤ 87600 h 10...40, für Gebrauchsdauer ≤ 175200 h
Max. zulässige relative Luftfeuchtigkeit	[%]	5...95, kurzzeitig 5...70, dauerhaft
Luftdruck	[kPa]	80...106
Höhe über NN	[m]	< 2000
Salznebel		nein
Schutzart		IP 67 / IP 69K; geschützte Kabelverlegung

### Zulassungen / Prüfungen

EMV		IEC 60947-5-2
Schockfestigkeit		EN 60068-2-27: 30 g (11 ms)
Vibrationsfestigkeit		IEC 60068-2-6 10 g (10...55 Hz)

### Sicherheitskennwerte

Gebrauchsdauer TM (Mission Time)	[h]	≤ 175200, (20 Jahre)
B10d		20.000.000; (ohne Last); 400.000 (bei max. Last DC 12, 24 V, 50 mA)

### Mechanische Daten

Einbauart		nicht bündig einbaubar
Gehäusewerkstoffe		PA; Befestigungsplatte: Edelstahl (1.4301)
Anzugsdrehmoment	[Nm]	0,8...2
Gewicht	[kg]	0,449

### Anzeigen / Bedienelemente

Anzeige		-
---------	--	---

### Elektrischer Anschluss

Anschluss		PVC-Kabel / 6 m; 4 x 0,25 mm <sup>2</sup> ; Ø 50 mm
-----------	--	---

### Anschlussbelegung

Adernfarben  
 BK schwarz  
 BN braun  
 BU blau  
 WH weiß

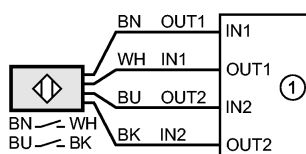

1: Sicherheitsgerichtete Logikeinheit

### Zubehör

Zubehör (mitgeliefert)		Codierter Betätiger
------------------------	--	---------------------

### Bemerkungen

Verpackungseinheit	[Stück]	1
--------------------	---------	---

**MN501S**

MN44008-AKOG/6m/-H

**Magnetsensor****Weitere Daten**

Potentialfreiheit	ja
Codierungsstufe nach EN ISO 14119	niedrig

ifm electronic gmbh • Friedrichstraße 1 • 45128 Essen — Technische Änderungen behalten wir uns ohne Ankündigung vor! — DE — MN501S — 14.09.2017

**MN501S**

MN44008-AKOG/6m/-H

Magnetic sensor

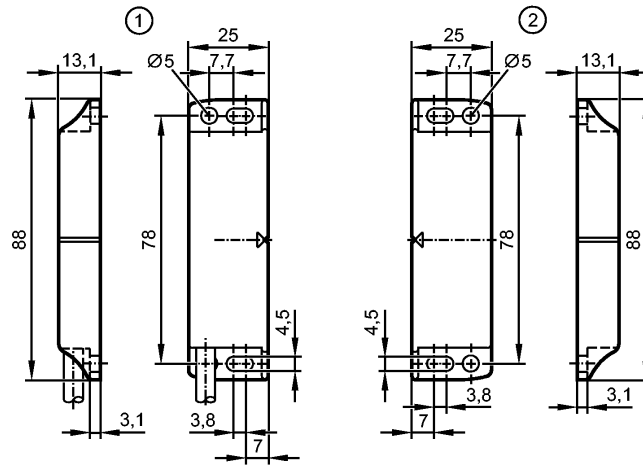

1: Sensor  
2: Coded target



**Product characteristics**

Magnetically coded sensor
Rectangular, plastics
Cable
Coded target
Sensing range (Sn) 8 mm; with coded target; [nf] non-flush mountable
Complies with the requirements: EN ISO 13849-1: 2015 category 4 PL e (In connection with a G150xS / AC42xS type evaluation unit, it is possible to reach up to PL e (ISO 13849-1) or SIL cl 3 (IEC 62061)). IEC 62061: SILcl 3

**Application**

Application	for safety-related applications
Type of operation	continuous operation

**Electrical data**

Electrical design	DC
Operating voltage [V]	24 DC
Rated insulation voltage [V]	120
Protection class	III
Reverse polarity protection	no
Internal resistance (Ri) [Ω]	10 (1 W)

**Outputs**

Output function	2 x normally open
Output data	Interface type A
Voltage drop [V]	1
Current rating [mA]	50
Short-circuit proof	no
Switching frequency [Hz]	150
Switching power (max.) [W]	6
Max. capacitive load CL_max [nF]	20

**Detection range**

Sensing range (Sn) [mm]	8, with coded target
-------------------------	----------------------

**MN501S**

MN44008-AKOG/6m/-H

**Magnetic sensor**

Safe switching off distance s(ar)[mm]	20
---------------------------------------	----

**Response times**

Response time to safety request[ms]	10
Fall time [ms]	0.1
Make time incl. bounce [ms]	0.6

**Environment**

Applications	Class C to EN 60654-1 weatherproof application
Ambient temperature [°C]	-25...80, for service life ≤ 87600 h 10...40, for service life ≤ 175200 h
Max. relative air humidity [%]	5...95, briefly 5...70, permanently
Air pressure [kPa]	80...106
Height above sea level [m]	< 2000
Salt spray	no
Protection	IP 67 / IP 69K; protected cable installation

**Tests / approvals**

EMC	IEC 60947-5-2
Shock resistance	EN 60068-2-27: 30 g (11 ms)
Vibration resistance	IEC 60068-2-6 10 g (10...55 Hz)

**Safety classification**

Mission time TM [h]	≤ 175200, (20 years)
B10d	20.000.000; (without load); 400.000 (at max. load DC 12, 24 V, 50 mA)

**Mechanical data**

Mounting	non-flush mountable
Housing materials	PA; fixing plate: stainless steel (1.4301)
Tightening torque [Nm]	0.8...2
Weight [kg]	0.449

**Displays / operating elements**

Display	-
---------	---

**Electrical connection**

Connection	PVC cable / 6 m; 4 x 0.25 mm <sup>2</sup> ; Ø 50 mm
------------	---

**Wiring**

- Core colours
- BK black
- BN brown
- BU blue
- WH white

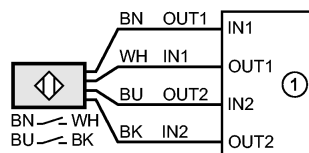

1: Safety-related logic unit

**Accessories**

Accessories (included)	Coded target
------------------------	--------------

**Remarks**

Pack quantity [piece]	1
-----------------------	---

**Other data**

potential-free	yes
----------------	-----



**MN501S**

MN44008-AKOG/6m/-H

**Magnetic sensor**

Coding level to EN ISO 14119

low

**MN501S**

MN44008-AKOG/6m/-H

Détecteur magnétique

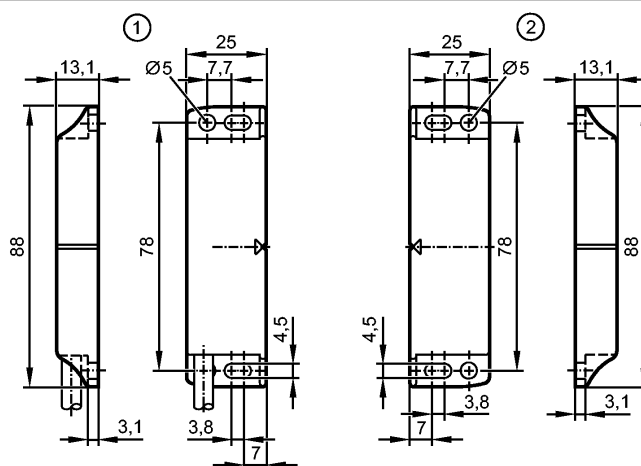

1: Capteur  
2: Cible codée



**Caractéristiques du produit**

Détecteur à codage magnétique
Boîtier parallélépipédique plastique
Raccordement par câble
Cible codée
Portée (Sn) 8 mm; avec cible codée; [nb] non encastrable
Conforme aux exigences: EN ISO 13849-1: 2015 Catégorie 4 PL e (en combinaison avec un boîtier de contrôle de type G150xS / AC42xS, il est possible d'atteindre jusqu'à PL e (ISO 13849-1) ou SIL cl 3 (CEI 62061)). CEI 62061: SILcl 3

**Application**

Application	pour applications de sécurité
Mode fonctionnement	fonctionnement permanent

**Données électriques**

Technologie	DC
Tension d'alimentation [V]	24 DC
Tension d'isolement assignée [V]	120
Classe de protection	III
Protection contre l'inversion de polarité	non
Résistance interne (Ri) [Ω]	10 (1 W)

**Sorties**

Sortie	2 x normalement ouvert
Données de sortie	Interface type A
Chute de tension [V]	1
Courant de sortie [mA]	50
Résistant aux courts-circuits	non
Fréquence de commutation [Hz]	150
Pouvoir de coupure (max.) [W]	6
Charge capacitive maximale CL_max [nF]	20

**Portée**

## MN501S

MN44008-AKOG/6m/-H

Détecteur magnétique

Portée (Sn)	[mm]	8, avec cible codée
-------------	------	---------------------

Distance de déclenchement sûres(ar)	[mm]	20
-------------------------------------	------	----

### Temps de réponse

Temps de réponse pour la mise en sécurité	[ms]	10
---	------	----

Durée de coupure	[ms]	0,1
------------------	------	-----

Durée d'établissement y compris rebondissement	[ms]	0,6
--	------	-----

### Conditions d'utilisation

Applications	Classe C selon EN 60654-1 lieu protégé contre les intempéries	
--------------	---	--

Température ambiante	[°C]	-25...80, pour la durée d'utilisation ≤ 87600 h 10...40, pour la durée d'utilisation ≤ 175200 h
----------------------	------	--

Humidité relative de l'air max.	[%]	5...95, brièvement 5...70, continuellement
---------------------------------	-----	---

Pression d'air	[kPa]	80...106
----------------	-------	----------

Altitude d'utilisation	[m]	< 2000
------------------------	-----	--------

Brouillard salin		non
------------------	--	-----

Protection		IP 67 / IP 69K; pose sécurisée des câbles
------------	--	---

### Tests / Homologations

CEM		CEI 60947-5-2
-----	--	---------------

Tenue aux chocs	EN 60068-2-27 :	30 g (11 ms)
-----------------	-----------------	--------------

Tenue aux vibrations	CEI 60068-2-6	10 g (10...55 Hz)
----------------------	---------------	-------------------

### Classification de sécurité

Durée d'utilisation TM (Mission Time)	[h]	≤ 175200, (20 ans)
---------------------------------------	-----	--------------------

B10d		20.000.000; (sans charge) ; 400 000 (pour charge max. DC 12, 24 V, 50 mA)
------	--	---

### Données mécaniques

Montage		non encastrable
---------	--	-----------------

Matières boîtier		PA; plaque de fixation: inox (1.4301)
------------------	--	---------------------------------------

Couple de serrage	[Nm]	0,8...2
-------------------	------	---------

Poids	[kg]	0,449
-------	------	-------

### Afficheurs / éléments de service

Indication		-
------------	--	---

### Raccordement électrique

Raccordement		câble PVC / 6 m; 4 x 0,25 mm <sup>2</sup> ; Ø 50 mm
--------------	--	---

#### Branchement

Couleurs des fils conducteurs

- BK noir
- BN brun
- BU bleu
- WH blanc

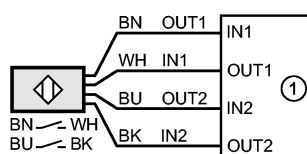

1: Bloc logique relatif à la sécurité

### Accessoires

Accessoires (fournis)		Cible codée
-----------------------	--	-------------



**MN501S**

MN44008-AKOG/6m/-H

**Détecteur magnétique**

Remarques	
Quantité	[pièce] 1
Données supplémentaires	
Absence de potentiel	oui
Niveau de codage selon EN ISO 14119	bas