

ifm electronic

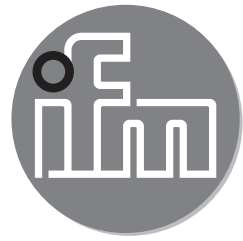

Operating instructions
Electronic level sensor

efector160[®]

LR9020

LXxxxx

UK

80227276 / 00 01/ 2016

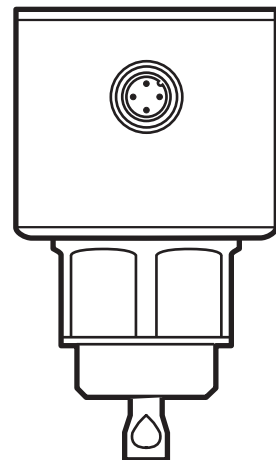

Contents

1	Preliminary note.....	4
1.1	Symbols used	4
2	Safety instructions	4
3	Items supplied.....	5
4	Functions and features	5
4.1	Operation with single probe.....	6
4.2	Operation with coaxial probe	6
4.3	Applications	6
4.3.1	Restriction of the application area	7
5	Function.....	8
5.1	Measuring principle	8
5.2	Features of the unit.....	8
5.2.1	Set-up via IO-Link.....	8
5.2.2	Analogue function	9
5.2.3	Probes for different tank heights.....	10
5.2.4	Defined state in case of a fault	10
5.2.5	IO-Link.....	10
6	Installation.....	11
6.1	Installation location / environment	11
6.1.1	Unit with single probe	11
6.1.2	Unit with coaxial probe	14
6.2	Installation of the probe	14
6.2.1	Installation of the rod	14
6.2.2	Installation of the coaxial pipe	15
6.3	Shortening of the probe	16
6.3.1	How to shorten the rod and to determine its length L.....	16
6.3.2	Shortening of the coaxial pipe	16
6.3.3	Determination of the rod length L when coaxial probes are used.....	17
6.4	Installation of the unit with single probe.....	17
6.4.1	Installation in closed metal tanks (without flange plate)	18
6.4.2	Installation in closed metal tanks (with flange plate)	18
6.4.3	Installation in open tanks	19
6.4.4	Installation in plastic tanks	20

6.5	Installation of the unit with coaxial probe in the tank	21
6.6	Alignment of the sensor housing	21
7	Electrical connection.....	21
8	Operating and display elements	22
9	Parameter setting	22
9.1	Parameter setting via PC.....	23
9.2	Parameter setting via the memory plug.....	23
10	Operation.....	24
10.1	Operating and diagnostic messages via IO-Link	24
10.2	Output response in different operating states.....	24
10.3	Setting ranges	24
11	Maintenance	24
12	Factory setting	25

1 Preliminary note

1.1 Symbols used

► Instructions

> Reaction, result

[...] Designation of keys, buttons or indications

→ Cross-reference



Important note

Non-compliance may result in malfunction or interference.



Information

Supplementary note.

2 Safety instructions

- Please read this document prior to set-up of the unit. Ensure that the product is suitable for your application without any restrictions.
- If the operating instructions or the technical data are not adhered to, personal injury /or damage to property can occur.
- Improper or non-intended use may lead to malfunctions of the unit or to unwanted effects in your application. That is why installation, electrical connection, set-up, operation and maintenance of the unit must be carried out by qualified personnel authorised by the machine operator.
- In order to guarantee the correct condition of the device for the operating time it is necessary to use the device only for media to which the wetted materials are sufficiently resistant (→ Technical data).
- The responsibility whether the measurement devices are suitable for the respective application lies with the operator. The manufacturer assumes no liability for consequences of misuse by the operator. Improper installation and use of the units result in a loss of the warranty claims.
- The national and international regulations for the installation of electrical equipment must be adhered to.
- The unit complies with the standard EN 61000-6-4 and is a class A product. The radiated energy of the microwaves is, for example, much below that of mobile phones. According to the current state of science the operation of the unit can be classified to be harmless to human health.

- The unit may cause radio interference in domestic areas. If interference occurs, the user must take appropriate remedial actions.

3 Items supplied

- Level sensor LR9020 or LXxxxx
- Operating instructions

In addition, the following is necessary for installation and operation:

- Rod (for operation of the unit with single probe → 4.1)
- If required, 1 coaxial pipe (for operation of the unit with coaxial probe → 4.2)
- Mounting material (if necessary, a launching plate → 4.1).



Only use accessories from ifm electronic gmbh! The optimum function is not ensured when using components from other manufacturers.



Available accessories: www.ifm.com



Set-up requires a PC with IO-Link compatible software or a memory plug with corresponding programming.

More information → 5.2.5 and → 9.

4 Functions and features

The unit continuously detects the level in tanks and generates output signals according to the parameter settings.

2 outputs are available:

- OUT1: Level via IO-Link.

More information → 5.2.5 and → 9.

- OUT2: analogue signal proportional to the level 4...20 mA / 0...10 V

4.1 Operation with single probe

The single probe is made up of one individual rod. Operation with single probe is suited for the detection of aqueous media, in particular of heavily soiled aqueous media.



For the correct function with single probe, the unit needs a large enough metal launching plate. It is necessary for transferring the microwave pulse to the tank with optimum transmission power.

The flange plates that are available as accessories are not sufficient as launching plates (for suitable launching plates → 6.4).

For installation in closed metal tanks, the tank lid serves as a launching plate. For installation in open metal tanks, tanks made of plastic or metal tanks with plastic lids, a sufficiently large fixing plate, a metal plate or similar must be used (→ 6.4.3 / → 6.4.4).

For operation with single probe, minimum distances to tank walls, objects in the tank, bottom of the tank and further level sensors must be adhered to (→ 6.1.1).

4.2 Operation with coaxial probe

The coaxial probe is made up of an inner rod and an outer probe pipe (coaxial pipe). The rod is centered in the coaxial pipe by one or several spacers.

In case of operation with a coaxial probe, media with a low dielectric constant (e.g. oil and oil-based media) are detected in addition to aqueous media.



No launching plate is required for operation with coaxial probe.

Furthermore, no minimum distances to tank walls and objects in the tank are required.

4.3 Applications

- Water, water-based media
- Oils, oil-based media (only for operation with coaxial probe)
- For applications under difficult environmental conditions (e.g. weather) (→ Technical data sheet).

Application examples:

- Detection of coolant emulsion in a machine tool.
- Detection of cleaning liquid in a parts cleaning system.
- Monitoring of hydraulic oil in a hydraulic power unit (only for operation with coaxial probe)
- Detection of Diesel fuel (only for operation with coaxial probe, in non hazardous areas!).

4.3.1 Restriction of the application area

- The unit is not suitable for bulk materials (e.g. plastic granulates)
- If the unit is to be used in acids or alkalis, in hygienic areas or in electroplating applications: first check the compatibility of the product materials (→ Technical data sheet) with the media to be monitored.
- Incorrect measurements or signal loss may be caused by the following media:
 - Highly absorbing surfaces (e.g. foam).
 - Intensely bubbling surfaces.
 - Media which are very inhomogeneous, separate from each other thus forming separation layers (e.g. oil layer on water).
 - ▶ Check the function with an application test.
 - > The unit reports any signal loss via IO-Link and provides a defined signal at the analogue output (→ 5.2.4).
- The unit is not suitable for applications where the probe is subjected to permanent and high mechanical stress (e.g. strongly moving viscous media or strongly flowing media).
- In case of operation with single probe: use preferably in metal tanks. When installed in plastic tanks, deterioration caused by electromagnetic interference may occur (noise immunity to EN61000-6-2).
Corrective measures: → 6.4.4.
- In case of operation with coaxial probe: not suitable for viscous media and media prone to formation of deposit. Maximum viscosity: 500 mPa · s.

5 Function

5.1 Measuring principle

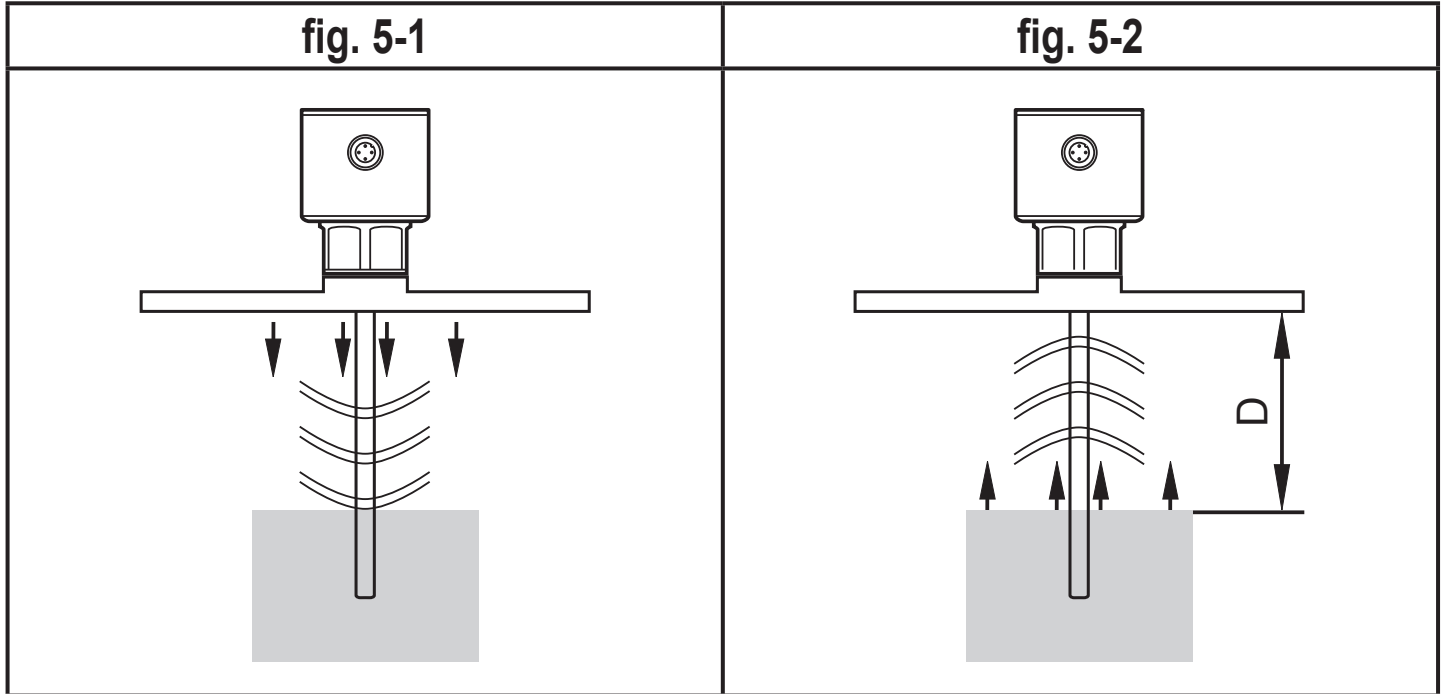

The unit operates to the principle of guided wave radar. It measures the level using electromagnetic pulses in the nanosecond range.

The pulses are transmitted by the sensor head and guided along the rod (fig. 5-1). When they hit the medium to be detected they are reflected and guided back to the sensor (fig. 5-2). The time between transmitting and receiving the pulse directly relates to the travelled distance (D) and the current level. The reference for distance measurement is the lower edge of the process connection.



The figures show the operation with single probe. In case of operation with a coaxial probe, the guided wave runs only along the inside of the coaxial pipe.

5.2 Features of the unit

5.2.1 Set-up via IO-Link

- The device parameters are set via the IO-Link interface (→ 5.2.5 and → 9).
- All settings can also be carried out before installation of the unit.

5.2.2 Analogue function

The unit provides an analogue signal proportional to level. The analogue output (OUT2) can be configured.

- [OU2] defines the output function of the analogue output:
 - [OU2] = [I] the measuring range is provided as 4...20 mA.
 - [OU2] = [InEG] the measuring range is provided as 20...4 mA.
 - [OU2] = [U] the measuring range is provided as 0...10 V.
 - [OU2] = [U] the measuring range is provided as 10...0 V.

Curve of the analogue signal (factory setting):

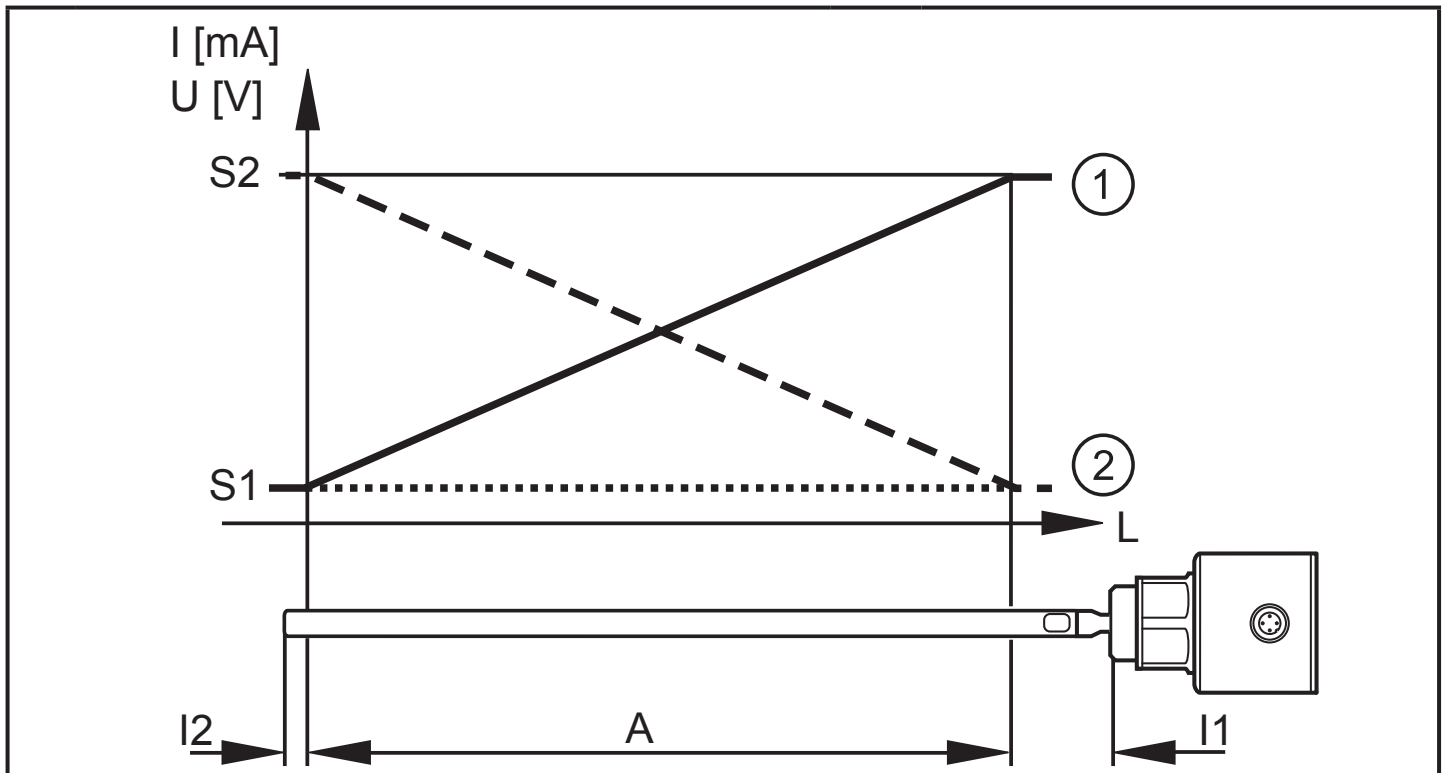

L: Level

A: Active zone

I1: Inactive zone 1

I2: Inactive zone 2 (→ Technical data sheet)

①: [OU2] = I / U (factory setting)

②: [OU2] = [InEG] / [UnEG]

Note the tolerances and accuracy limits during the evaluation of the analogue signal (→ Technical data sheet).

5.2.3 Probes for different tank heights

- The unit can be installed in tanks of different sizes. Probes in different lengths are available. To adapt to the tank height, each probe can be shortened. The minimum probe length is 10 cm, the maximum probe length is 160 cm.
- Probe and housing can be rotated without restriction. This enables easy installation and orientation of the head of the unit after installation.

5.2.4 Defined state in case of a fault

- If a fault is detected or if the signal quality is below a minimum value, the analogue output passes into a defined state. For this case, the response of the output can be set via the parameter [FOU2].
- Temporary loss of signal caused e.g. by turbulence or foam formation can be suppressed by a delay time (→ 9.1 [dFo]). During the delay time the last measured value is frozen. If the measured signal is received again in sufficient strength within the delay time, the unit continues to work in normal operation. If, however, it is not received again in sufficient strength within the delay time, the output passes into the defined state.

5.2.5 IO-Link

General information

This unit has an IO-Link communication interface which requires an IO-Link-capable module (IO-Link master) for operation.

The IO-Link interface enables direct access to the process and diagnostic data and provides the possibility to set the parameters of the unit during operation. In addition communication is possible via a point-to-point connection with a USB adapter cable.

For further information about IO-Link view: www.ifm.com/gb/io-link.

Device-specific information

You will find the IODDs necessary for the configuration of the IO-Link unit and detailed information about process data structure, diagnostic information and parameter addresses at www.ifm.com/gb/io-link.

Parameter setting tools

You will find all necessary information about the required IO-Link hardware and software at www.ifm.com/gb/io-link.

6 Installation

6.1 Installation location / environment

- Vertical installation from the top is preferred.

6.1.1 Unit with single probe

- For safe functioning, the unit requires a launching plate (→ 6.4).
- The following minimum distances between the rod and tank walls, objects in the tank (B), tank bottom and other level sensors must be adhered to:

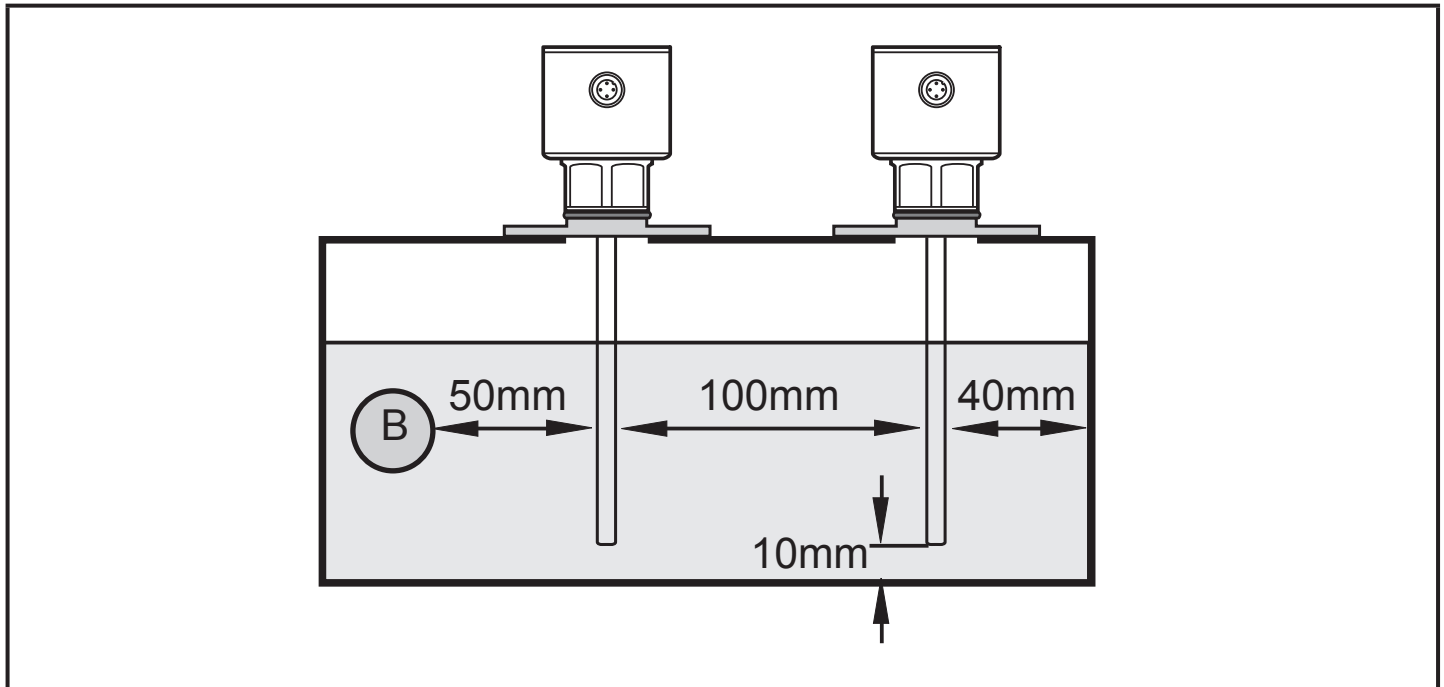

- For tank walls which are not straight, steps, supports or other structures in the tank a distance of 50 mm to the tank wall must be adhered to.
- For probe lengths > 70 cm, the rod can be considerably deflected by movement of the medium. To avoid contacting the tank wall or other structures in the tank in such cases, the minimum distances should be increased. Reference values:

Probe length	Distance to the tank wall or structures in the tank
70...100 cm	100 mm
100...160 cm	180 mm

- If the medium is strongly polluted, there is the risk that a bridge forms between the rod and the tank wall or structures in the tank. To avoid incorrect measurements: adhere to increased minimum distances depending on type and intensity of the soiling.
- For installation in pipes:

- The inside pipe diameter (d) must be at least 100 mm (fig. 6-1).
- Only install the unit in metal pipes.
- For installation in connection pieces:
 - The diameter of the boss (d) must be at least 60 mm (fig. 6-2).
 - The height of the boss (h) must not exceed 40 mm (fig. 6-2).



Although the unit can be installed in a boss, installation in a flat tank lid is recommended. A boss will impede the distribution of the microwaves.

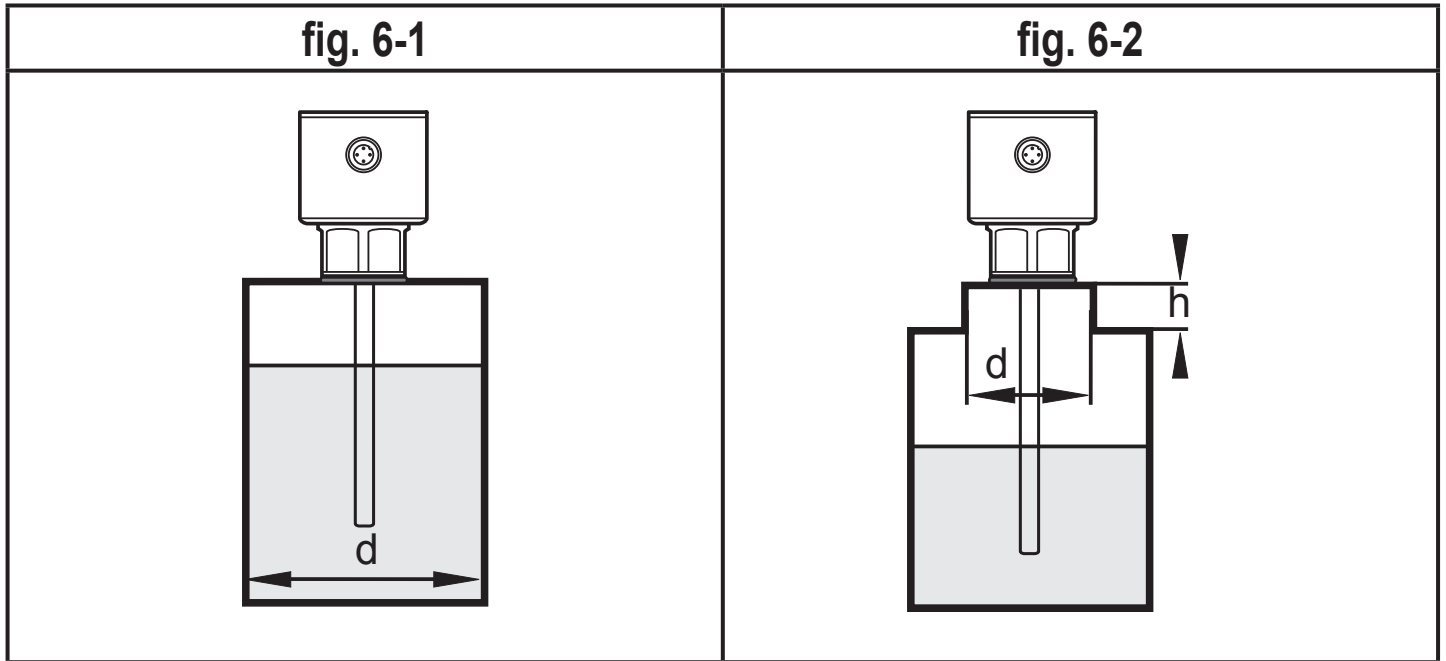

- Do not install the unit in the immediate vicinity of a fill opening (fig. 6-3). If possible, install a fill pipe (A) in the tank (fig. 6-4). Minimum distance between the fill pipe and the rod = 50 mm; higher for rod lengths > 70 cm and in case of heavy soiling (→ 6.1.1).

fig. 6-3

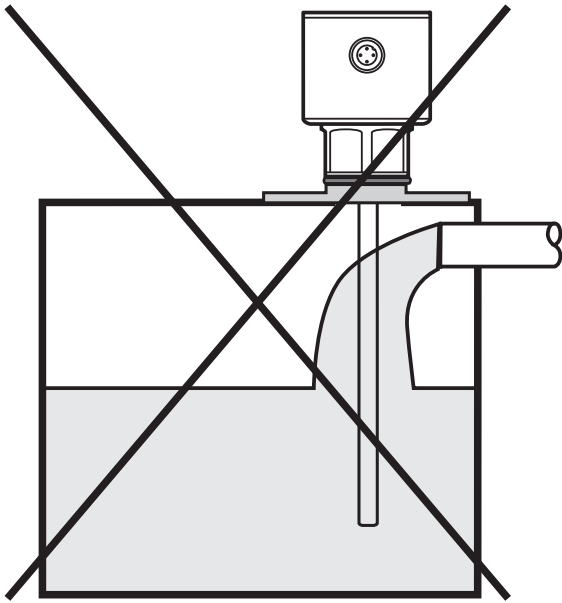
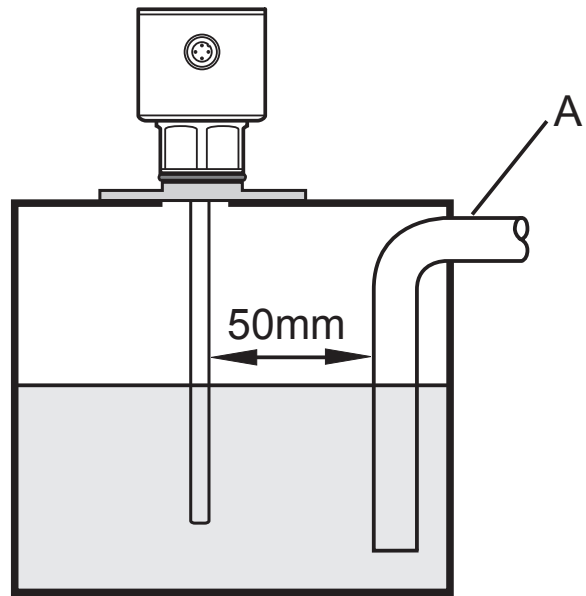
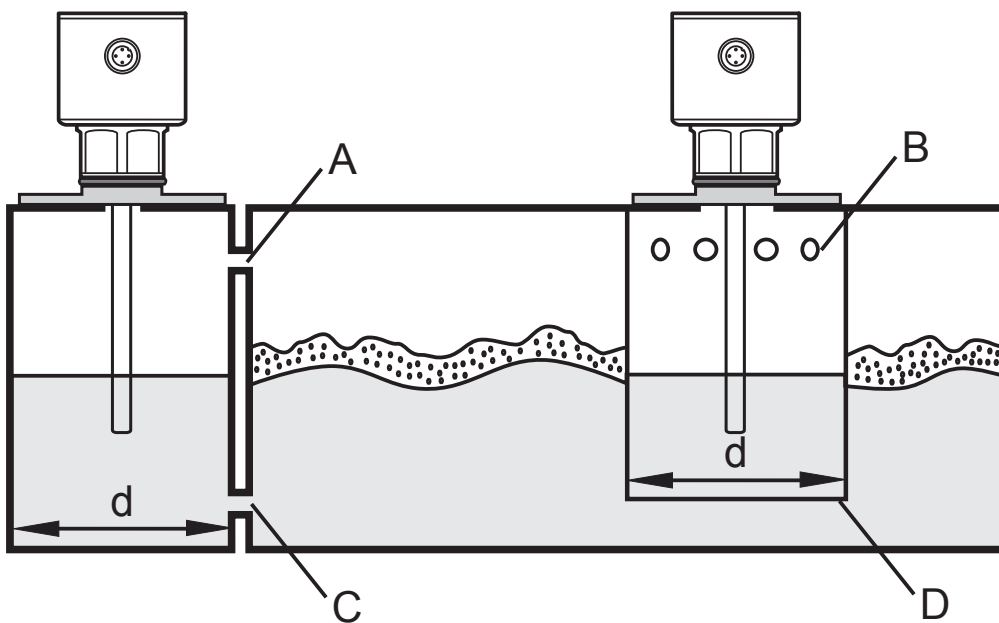

fig. 6-4



UK

- Strong foam formation and strongly moving surfaces can lead to malfunctions (see the following fig.). Recommended remedies: use a coaxial probe, install a still pipe or bypass. Note: minimum diameter $d = 100$ mm. The upper access to the bypass (A) and the fill openings of the still pipe (B) must be above the maximum level. The lower edges of the bypass (C) and of the still pipe (D) must be below the minimum level. This ensures that neither foam nor waves impact the sensor zone:



6.1.2 Unit with coaxial probe

- No minimum distances to the tank wall and the baffles (B) are required.
- Minimum distance to the bottom of the tank: 10 mm.
- The vent hole (A) must not be covered by mounting elements or similar.
- Do not install the unit in the immediate vicinity of a fill opening. No water jets must enter into the holes of the coaxial pipe.
- Note in case of foam formation: the vent of the coaxial pipe must be above the maximum level. The lower edge of the coaxial pipe must be below the minimum level.

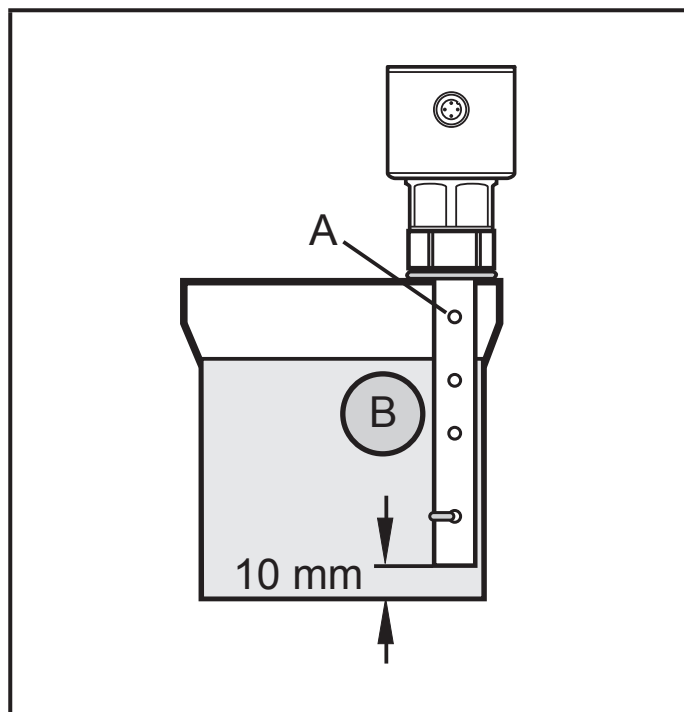

6.2 Installation of the probe

Rod and coaxial pipe are not included in the scope of delivery. They must be ordered separately (→ 3 Items supplied).

6.2.1 Installation of the rod

Fixing of the rod:

- ▶ Screw the rod to the unit and tighten it.

 Recommended tightening torque: 4 Nm.

For ease of installation and removal the rod connection can be rotated without restriction. Even if rotated several times there is no risk of damage to the unit.

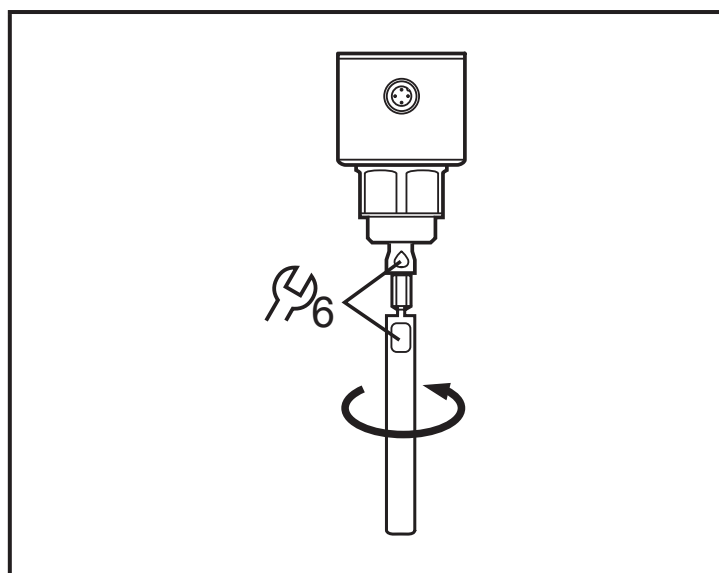

In case of high mechanical stress (strong vibration, moving viscous media) it may be necessary to secure the screw connection, e.g. by a screw retaining compound.



Substances such as screw retaining compounds may migrate into the medium. Make sure that they are harmless!

When using mechanical means of securing (e.g. tooth lock washer), protruding edges must be avoided. They may cause interference reflection.

6.2.2 Installation of the coaxial pipe

This subchapter is only relevant if the unit is to be operated with a coaxial probe.



The coaxial pipe and the rod must be of the same end length. The coaxial pipe can be shortened (→ 6.3.2).

- ▶ Screw the rod to the unit and tighten it. Recommended tightening torque: 4 Nm.
- ▶ Slide the sensor seal (A) onto the thread.
- ▶ Slide the coaxial pipe (B) onto the rod. Carefully center it and carefully move the rod through the centring piece (C) (for lengths > 140 cm through both centring pieces) of the coaxial pipe. Do not damage the centring pieces.
- ▶ Screw onto the sensor thread and tighten.

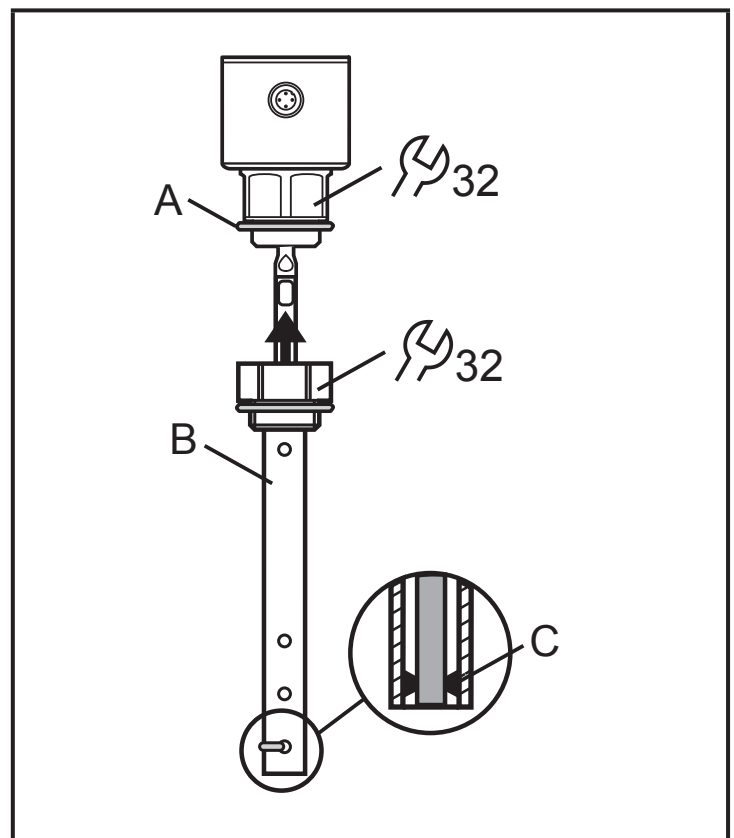

6.3 Shortening of the probe

6.3.1 How to shorten the rod and to determine its length L

The rod can be shortened to adapt the probe to different tank heights.



Ensure that the probe length is never below the minimum permissible probe length of 10 cm (L_{\min})! The unit does not support probe lengths below 10 cm. If shorter probes are used, measurement errors can occur.

Proceed as follows:

- ▶ Screw the probe to the unit.
- ▶ Mark the desired length (L) on the rod. The reference point is the lower edge of the process connection.
- ▶ Remove the rod from the unit.
- ▶ Shorten rod at the mark.

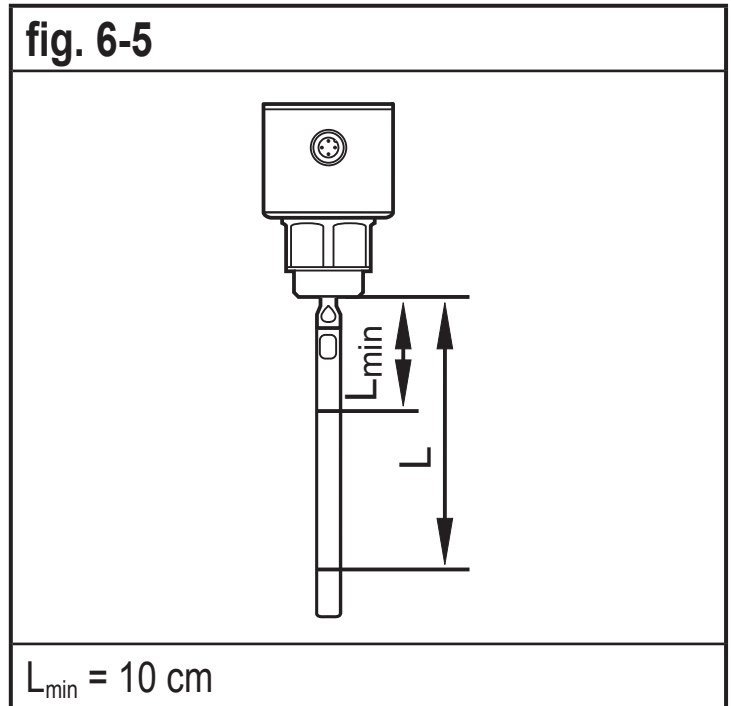

- ▶ Remove all burrs and sharp edges.
- ▶ Screw the rod to the unit again and tighten it. Recommended tightening torque: 4 Nm.
- ▶ Precisely measure the probe length L, note the value. It must be entered during parameter setting of the unit.

6.3.2 Shortening of the coaxial pipe

The coaxial pipe and the rod must be of the same end length:

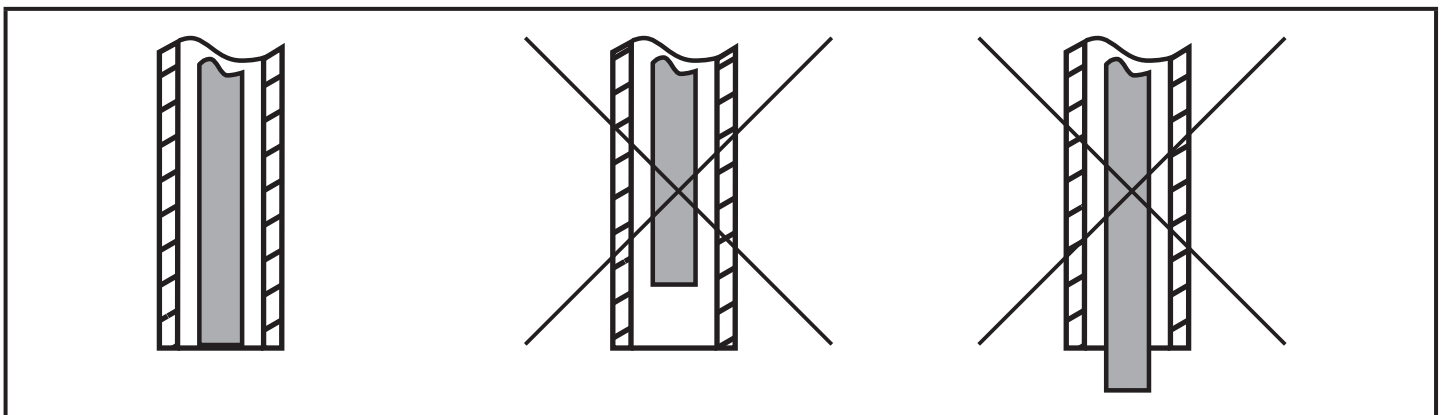

- ▶ Remove fastening bracket and centring piece (A, B).
- ▶ Shorten the coaxial pipe to the requested length: $L_K = L + 9 \text{ mm}$.
- ▶ After shortening, at least one hole (C) for insertion of the fixing bracket has to be left.
- ▶ Remove all burrs and sharp edges.
- ▶ Insert centring piece (A) at the lower end of the pipe and attach it using the fixing bracket (B) at the lower hole (C).

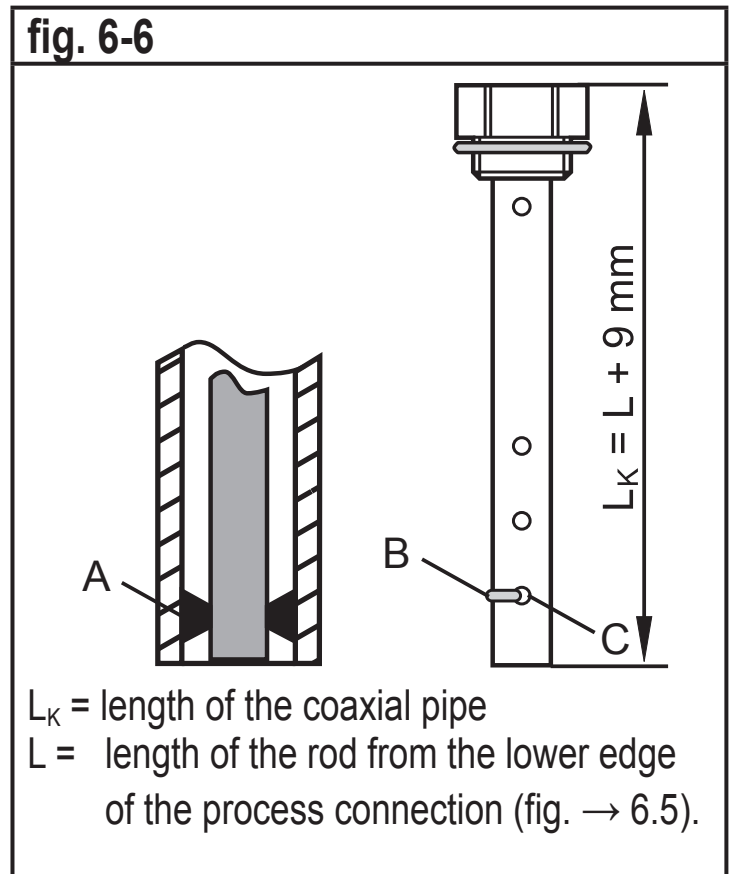

6.3.3 Determination of the rod length L when coaxial probes are used

Relevant in case the rod length L is unknown (fig. 6-5):

- ▶ Measure the exact total length L_K of the coaxial pipe (fig. 6-6).
- ▶ Deduct 9 mm from the total length of the coaxial pipe: $L = L_K - 9 \text{ mm}$.
- ▶ Note down L. Value L must be entered when setting the parameters of the device (\rightarrow 9.1 Parameter setting via PC).

6.4 Installation of the unit with single probe



For the correct function when used with single probe, the unit needs a large enough metal launching plate. It is necessary for transferring the microwave pulse to the tank with optimum transmission power. The flange plates that are available as accessories are not sufficient as launching plates.

For installation in closed metal tanks, the tank lid serves as a launching plate (R in fig. 6-7 and 6-11).

2 ways of installation are possible:

- Screw in a G $\frac{3}{4}$ process connection in the tank lid (\rightarrow 6.4.1).
- Installation in the tank lid using a flange plate, e.g. for tanks with thin walls (\rightarrow 6.4.2).

Furthermore, installation in open tanks (→ 6.4.3) and plastic tanks is possible (→ 6.4.4).

6.4.1 Installation in closed metal tanks (without flange plate)

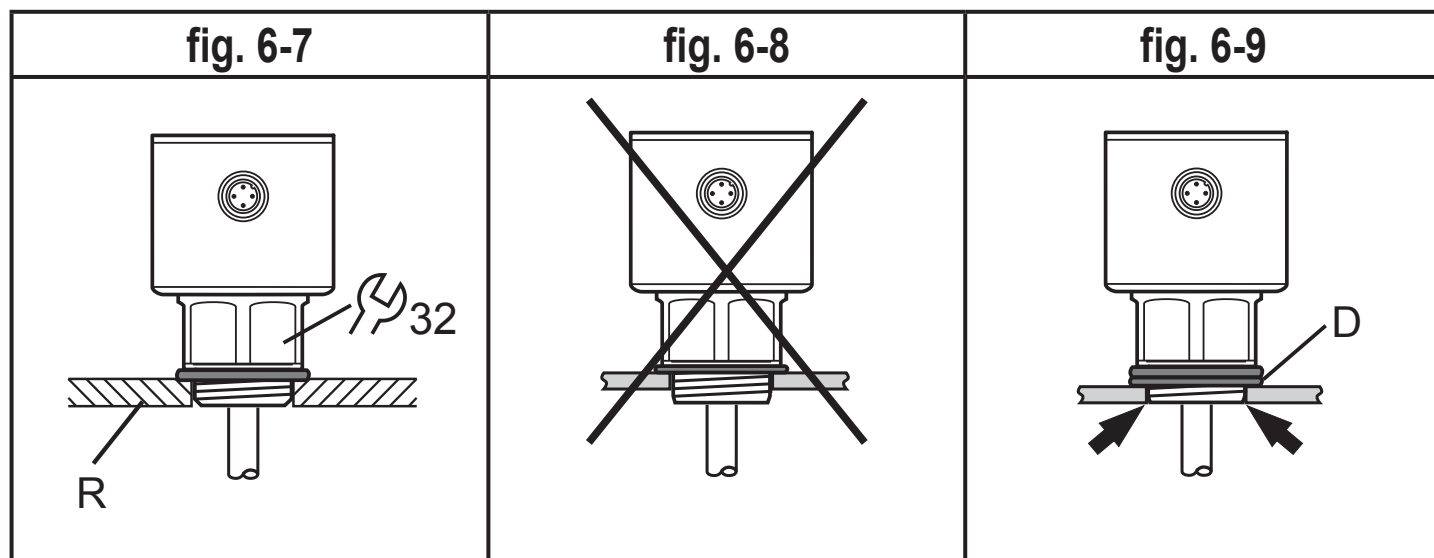

- ▶ The lower edge of the process connection should be flush with the installation environment (fig. 6-7).
- ▶ Avoid non-flush installation (fig. 6-8).
- ▶ Use seals or washers (D in fig. 6-9) to reach the required height.
- ▶ For tanks with thick walls arrange for sufficiently deep recesses to ensure flush installation.

6.4.2 Installation in closed metal tanks (with flange plate)

 Flange plates are not supplied. They must be ordered separately (→ 3 Items supplied).

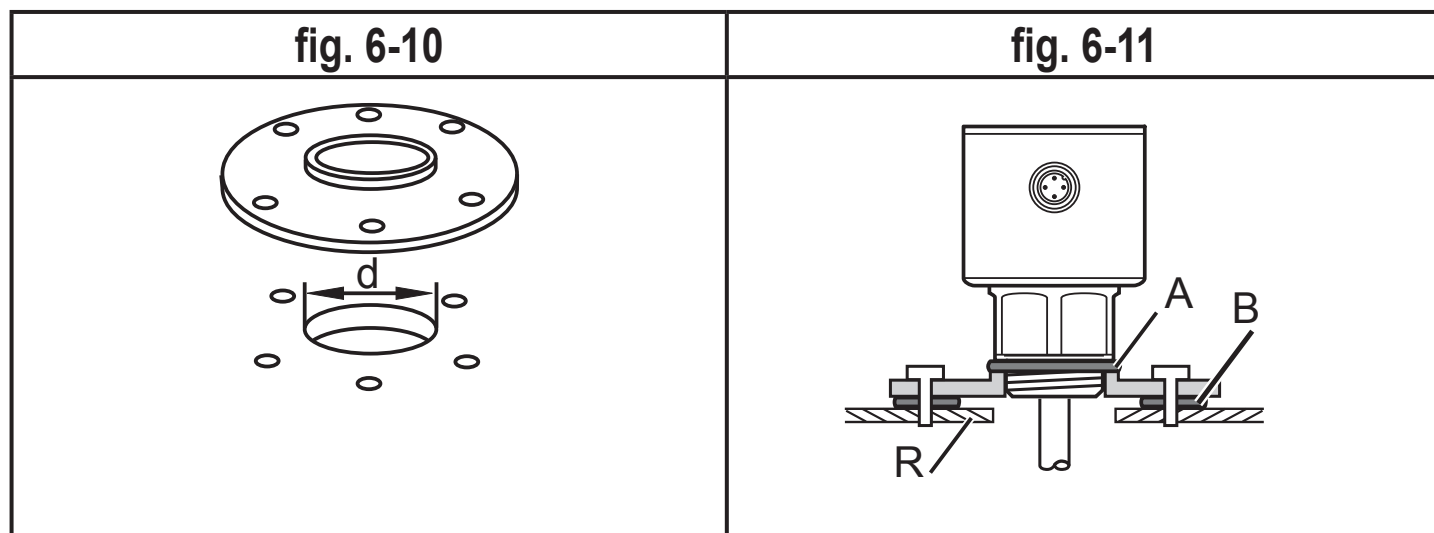

- ▶ Arrange for a bore hole in the tank lid. It must have a minimum diameter (d) to enable sufficient transfer of the measured signal to the probe (Abb. 6-10). The diameter depends on the wall thickness of the tank lid:

Wall thickness [mm]	1...5	5...8	8...11
Bore hole diameter [mm]	35	45	55

- ▶ Install the flange plate with the flat surface showing to the tank and fix it with appropriate screws.

 A seal (B in fig. 6-11) can be inserted between flange plate and tank. Some flange plates are supplied with a seal.

UK

- ▶ Ensure cleanness and evenness of the sealing areas, especially if the tank is under pressure. Tighten the fixing screws sufficiently.
- ▶ Screw the unit into the flange plate using the process connection and tighten firmly.
- ▶ Make sure that the supplied sensor seal (A in fig. 6-11) is correctly positioned.

6.4.3 Installation in open tanks

- ▶ For installation in open tanks, use a metal fixture to install the unit. It serves as a launching plate (R); Minimum size: 150 x 150 mm for a square fixture, 150 mm diameter for a circular fixture.
- ▶ If possible, mount the unit in the middle of the fixture. The distance D2 must not be below 40 mm, higher for probe lengths > 70 cm and in case of heavy soiling (→ 6.1.1):

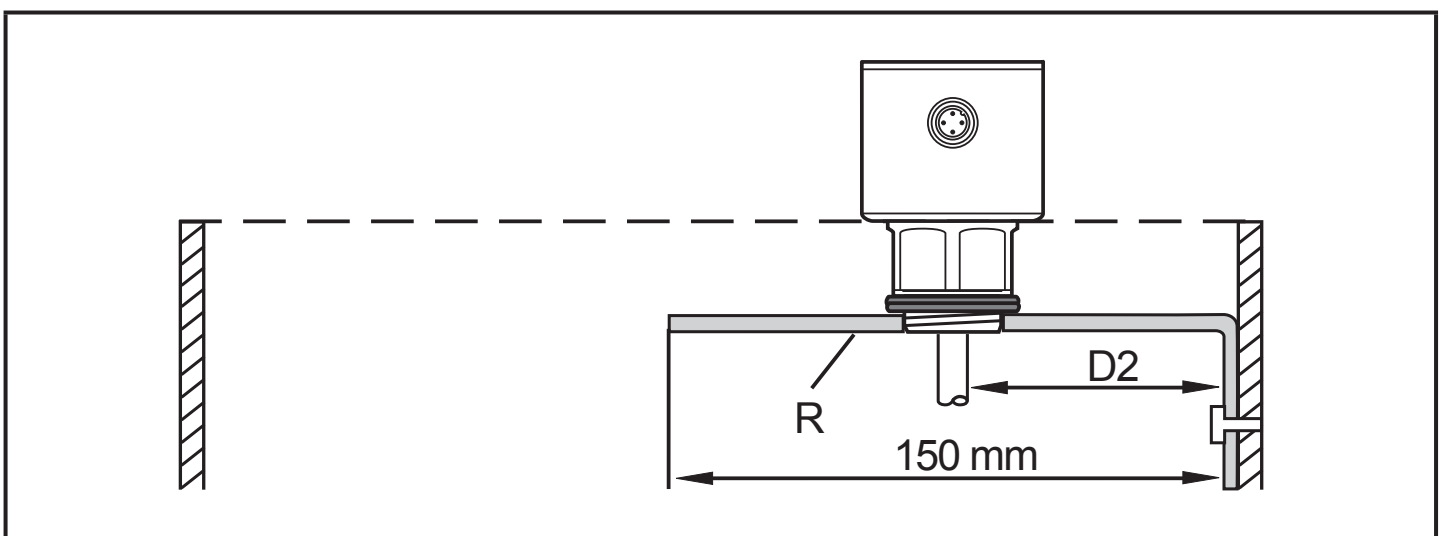

- ▶ The lower edge of the process connection should be flush with the installation environment (see fig. 6-7).
- ▶ Avoid non-flush installation (see fig. 6-8).
- ▶ Use seals or washers (see D in fig. 6-9) to reach the required height.

6.4.4 Installation in plastic tanks

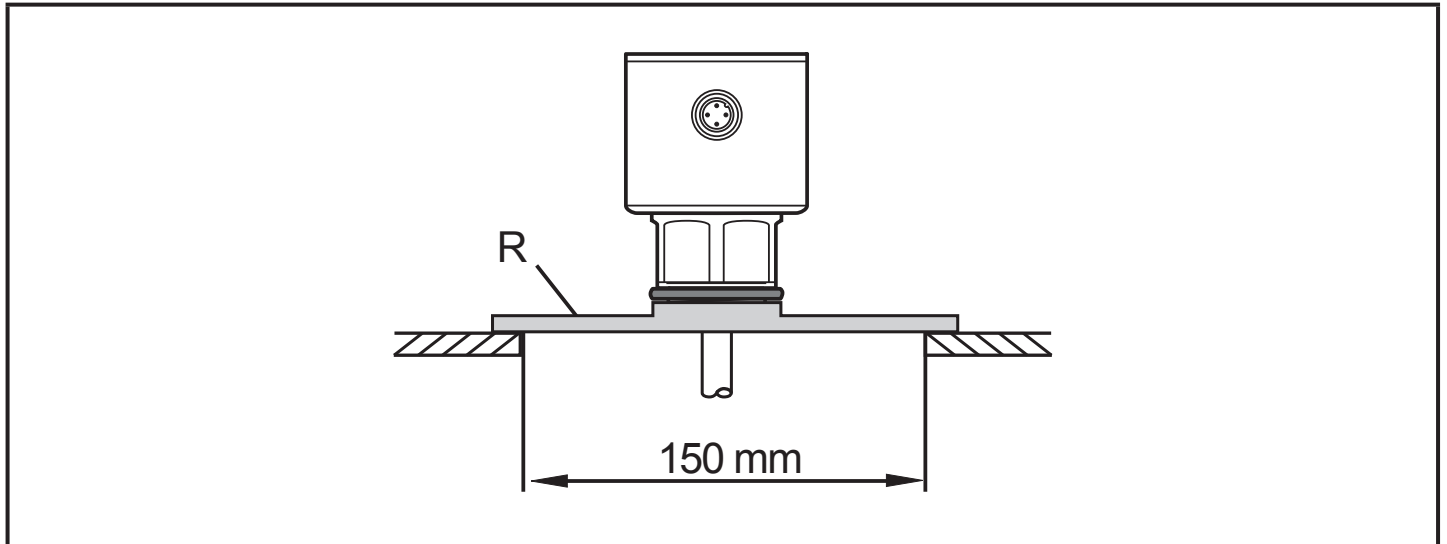

To enable sufficient transfer of the measured signal, note in case of installation in plastic tanks or metal tanks with plastic lid:

- ▶ The plastic lid must be provided with a drill hole with a minimum diameter of 150 mm.
- ▶ For installation of the unit, a metal flange plate (= launching plate R) must be used which sufficiently covers the drill hole.
- ▶ Ensure the minimum distance (= 80 mm) between rod and tank wall, higher for probe lengths > 70 cm and in case of heavy soiling (→ 6.1.1).



When installed in plastic tanks, there may be deterioration caused by electromagnetic interference. Corrective measures:

- Apply a metal foil to the outside of the tank.
- Apply a shielding screen between the level sensor and other electronic units.
- Operation with coaxial probe efficiently protects the unit from electromagnetic interference. Please note the restrictions regarding the application area (→ 4.3).

6.5 Installation of the unit with coaxial probe in the tank

► Seal the process connection:

- For pipes with G³/₄ process connection: slide the supplied seal onto the thread of the coaxial pipe.
- For pipes with ³/₄" NPT process connection: apply a suitable sealing material (e.g. Teflon tape).

► Screw the unit with the coaxial pipe into the tank and tighten it.

6.6 Alignment of the sensor housing



After installation, the sensor housing can be aligned. It can be rotated without restriction. Even if rotated several times there is no risk of damage to the unit.

UK

7 Electrical connection



The unit must be connected by a qualified electrician.

The national and international regulations for the installation of electrical equipment must be adhered to.

Voltage supply according to EN 50178, SELV, PELV.

► Disconnect power.

► Connect the unit as follows:

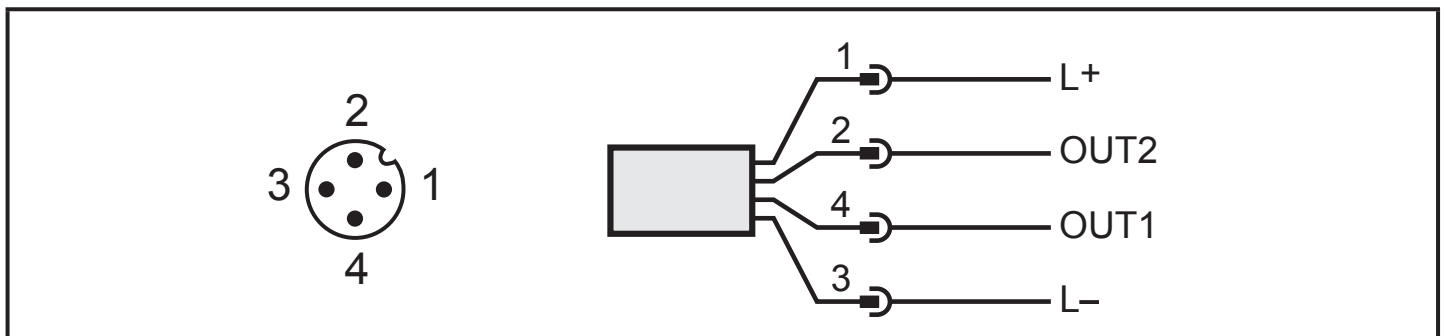

Pin	Connection	Core colours for ifm sockets
1	Ub+	brown
3	Ub-	blue
2	OUT2 = analogue output	white
4	OUT1 = IO-Link	black



When the unit is supplied with operating voltage for the first time, the parameters for the probe length, the medium to be detected and the type of probe used must be set. Only then is the unit ready for operation (→ 9).

8 Operating and display elements

This unit version has no operating and display elements.

For parameter setting → 9.



For units with display and operating elements → www.ifm.com.

9 Parameter setting

For parameter setting, a PC with IO-Link compatible software is required (→ 9.1) or a memory plug with corresponding programming (→ 9.2).

The parameters can be set prior to installation and setup of the unit or while in operation.



Changing parameters during operation can influence the function of the plant.

- ▶ Ensure that there will be no malfunctions in your plant.

The following subchapters describe the two different parameter setting options of the unit.

9.1 Parameter setting via PC

For parameter setting an IO-Link software is necessary (e.g. "LINERECORDER SENSOR" or "ifm Container"). The USB IO-Link interfaces with the order no. E30396 or E30390 are available for the connection of the sensor via the USB interface of a computer.



The catalogue of the available DTM objects, the IO-Link Device Description (IODD) and the FDT service program "ifm Container" can be downloaded at www.ifm.com → Service → Download

The following parameters can be set:

UK

OU2	Output function for the analogue output (OUT2): current or voltage output: I = 4...20 mA / U = 0...10 V, increasing or decreasing curve.
FOU2	Response of OUT2 in case of a fault.
dFo	Delay time for the output to pass into the state defined with [FOU2]; is only effective in case of a fault.
LEnG	Probe length.
MEdi	Medium to be detected: [HIGH] for water and water-based media [LOW] for oils and oil-based media (→ 4).
Prob	Type of probe used (single probe or coaxial probe). For [MEdi] = [LOW] the option [COAX] has to be set (→ 4).

For further information, please refer to the IODD description (→ www.ifm.com/gb/io-link) or to the context-specific parameter descriptions of the applied parameter setting software.

9.2 Parameter setting via the memory plug

Parameters can be set quickly and easily via a correctly set memory plug (memory module, order no. E30398).

- ▶ Load suitable parameter set (e.g. using a PC) to the memory plug
- ▶ Connect memory plug between sensor and socket
- > When voltage is supplied, the parameter set can be transferred from the memory plug to the sensor. Alternatively, a parameter can be written from the sensor to the memory plug.



The memory plug can also be used to save the current parameter setting of a unit and to transfer it to other units of the same type

You can find more information about the memory plug in the technical documentation for the article E30398 (available free of charge at www.ifm.com).

10 Operation

After power on, the unit is in the Run mode (= normal operating mode). It carries out its measurement and evaluation functions and generates output signals according to the set parameters.

10.1 Operating and diagnostic messages via IO-Link

IODD and IODD descriptive text as a pdf file at:
www.ifm.com/gb/io-link.

10.2 Output response in different operating states

	OUT1 *)	OUT2
Initialisation	Process value invalid	OFF
Normal operation	Process value according to the level	according to the level and OU2 setting
Fault	Process value invalid	4 mA / 0 V for FOU2 = OFF 20 mA / 10 V for FOU2 = on

*) process value via IO-Link

10.3 Setting ranges

[LEnG]	cm	inch
Setting range	10...160	4.0...63
Step increment	0.5	0.2

11 Maintenance

- ▶ Keep the process connection free of deposits and foreign bodies.
- ▶ In case of heavy soiling: clean the process connection and the probe at regular intervals.

In case of longer operation separation layers can form in the medium (e.g. oil on water). This applies especially to still pipes or bypasses.

- ▶ Remove separation layers at regular intervals.
- ▶ Ensure that the vent hole (at the upper end of the coaxial pipe) remains free.
- ▶ Keep the interior of the coaxial pipe free from foreign bodies and soiling.

12 Factory setting

(Special units LXxxxx*) not taken into account)

	Factory setting LR9020	User setting
OU2	I	
FOU2	OFF	
dFo	0	
LEnG	450	
MEdI	HIGH	
Prob	rod	

UK

*) Settings of the special units LXxxxx → Technical data sheet.

More information at www.ifm.com