

ifm electronic



Operating instructions  
Capacitive level sensor

**efector150**<sup>®</sup>

**KN5121**

**UK**

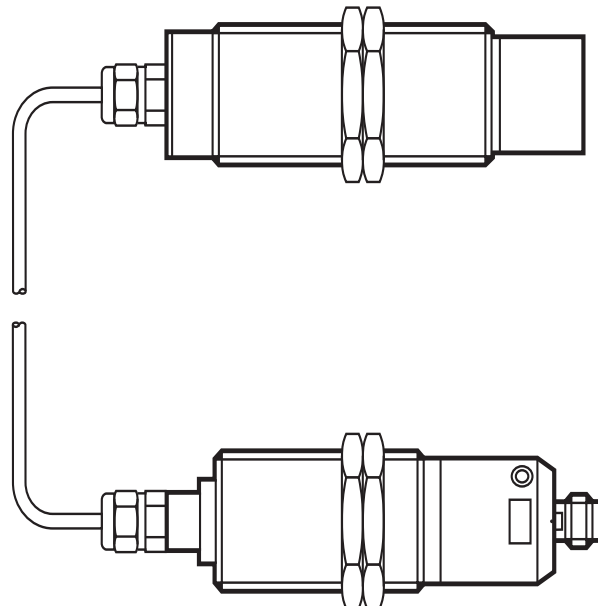

701824/00 02/2006

# Contents

1 Preliminary note.....	3
2 Safety instructions .....	3
3 Functions and features .....	3
4 Mounting .....	4
5 Electrical connection.....	5
5.1 Setting the output function as normally closed or normally open .....	5
5.2 Function check output / programming input .....	6
5.2.1 Signals on the function check output.....	6
5.2.2 Programming input .....	6
6 Operation .....	6
6.1 Programming .....	7
6.1.1 Empty adjustment.....	7
6.1.2 Full adjustment .....	8
6.1.3 Locking .....	8
6.1.4 Unlocking.....	9
6.1.5 Error messages .....	9
7 Operation .....	10
8 Maintenance, repair and disposal.....	11
9 Technical data.....	11

# 1 Preliminary note

► Instructions

> Reaction, result



Important note

Non-compliance can result in malfunction or interference.



Information

Supplementary note.

## 2 Safety instructions

UK

- Please read the operating instructions prior to set-up of the device. Ensure that the product is suitable for your application without any restrictions.
- The unit conforms to the relevant regulations and EC directives.
- Improper or non-intended use may lead to malfunctions of the unit or to unwanted effects in your application.
- Installation, electrical connection, set-up, operation and maintenance of the unit must only be carried out by qualified personnel authorised by the machine operator.

## 3 Functions and features

- Capacitive level sensor for monitoring of dry bulk material, preferably plastic granulates up to 250 °C.
- Automatic adjustment to the medium to be detected via programming button or programming input "CAL".
- The sensor element is rated for temperatures up to 250 °C and used in direct contact with the medium

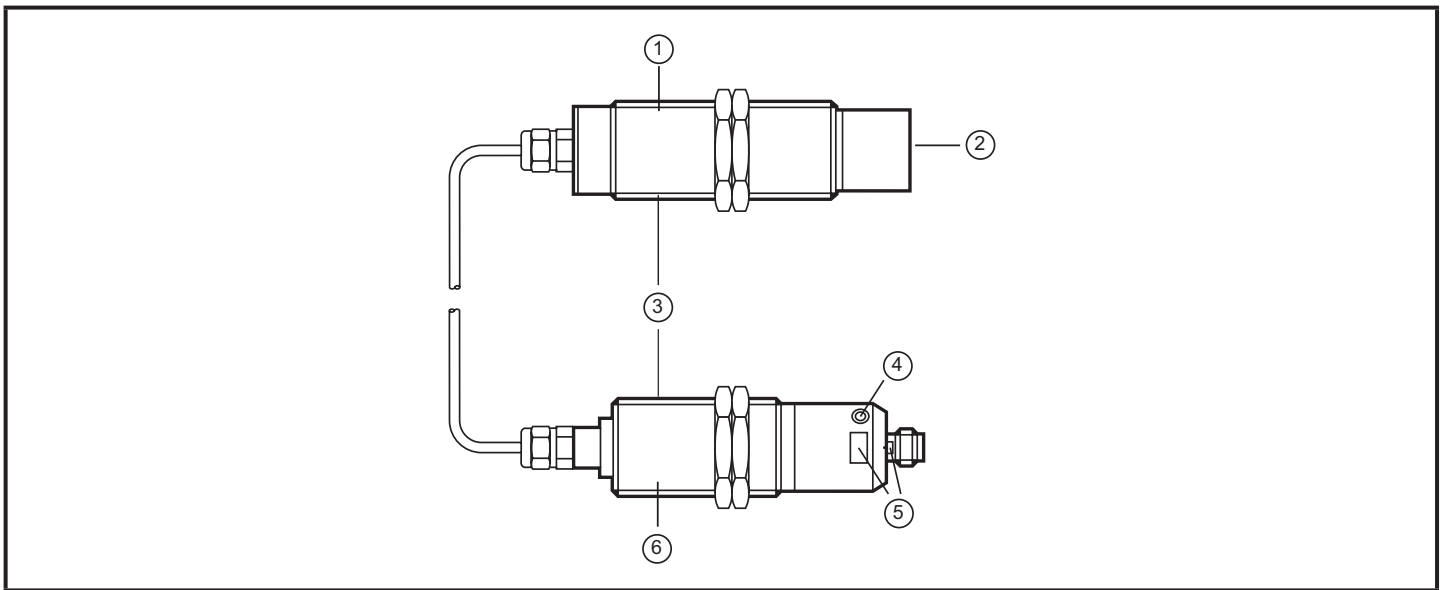

- 1: sensor
- 2: sensing face
- 3: threaded sleeve
- 4: programming button
- 5: LEDs red, yellow, green
- 6: evaluation electronics

## 4 Mounting



► Disconnect the system from power before mounting.

► Mount the unit as shown:

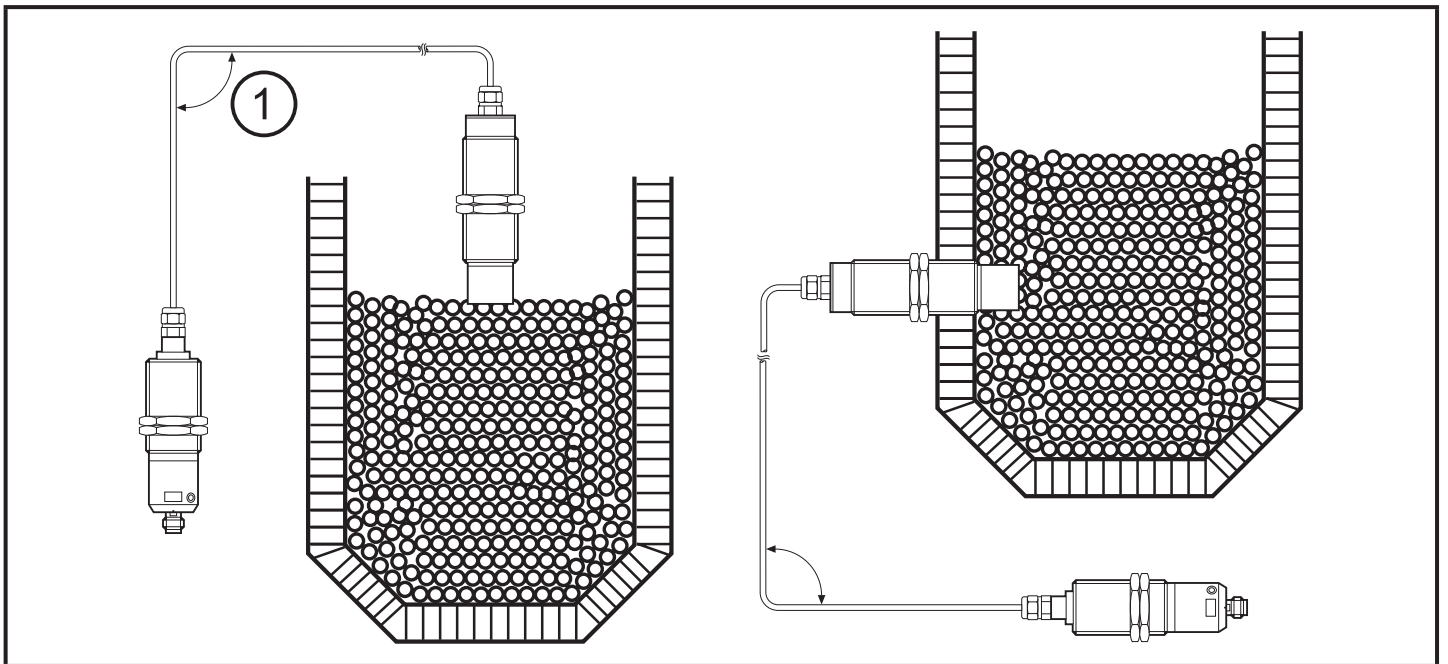

1: The connection cable must not be damaged. Minimum bending radius = 80 mm

## 5 Electrical connection



The unit must be connected by a qualified electrician.

The national and international regulations for the installation of electrical equipment must be adhered to.

- ▶ Disconnect power.
- ▶ Connect the unit.

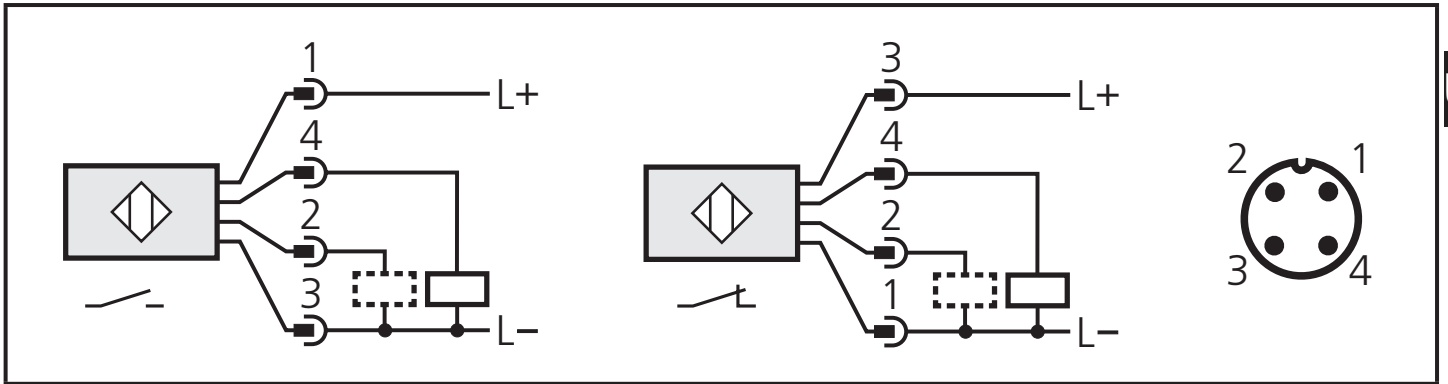

UK

p-switching (type FPKG)

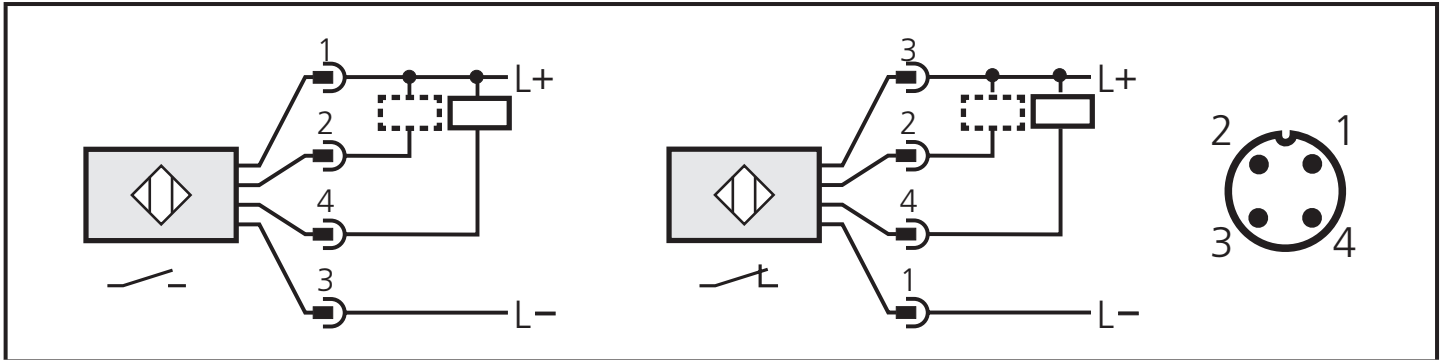

n-switching (type FNKG)

### 5.1 Setting the output function as normally closed or normally open

The switching output of the unit can be operated as normally closed or normally open.

- ▶ Switch off the unit.
- ▶ Connect the operating voltage by reversing the wires.
- > Inverted output response.

## 5.2 Function check output / programming input

You can select between function check output and programming input via the bidirectional wire (FC-OUT/CAL, pin 2).

- When used as function check output, output signals of the unit can be evaluated.
- When used as programming input, operations can be performed.

### 5.2.1 Signals on the function check output

Status	Signal
Function check	The function check output is enabled.
Adjustment error	The function check output changes between enabled and disabled state at 8 Hz.

### 5.2.2 Programming input

Type of unit	Performing an operation
p-switching (type FPKG)	▶ To activate the function the programming wire is electrically connected to the wire "L+".
n-switching (type FNKG)	▶ To activate the function the programming wire is electrically connected to the wire "L-".

## 6 Operation

- ▶ Adjust the sensor.
- ▶ Press the programming button with a blunt object.



- ▶ You can also operate the unit via the programming input "CAL" (signal duration = duration of the press of the pushbutton).

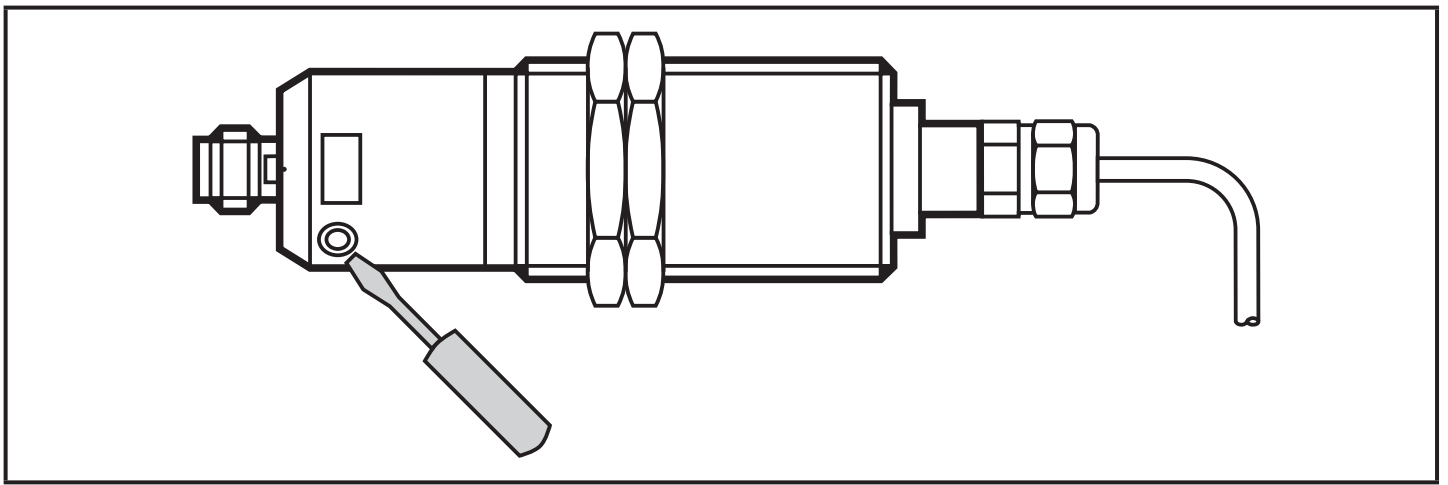

## 6.1 Programming

Overview of the modes and their basic functions

- Operating mode  
Normal operating mode, all sensor functions are active.
- Adjustment mode  
Setting of the switching threshold by empty and full adjustment.
- Locking mode  
Locking and unlocking of the unit possible to avoid tampering.

### 6.1.1 Empty adjustment.

► Adjust the unit in the empty tank after installation.



The tank can be considered to be "empty" when the medium to be detected is min. 20 mm away from the active zone. If the sensor detects a medium after adjustment, its switching status changes.

	<p>► Press the programming button until the green LED flashes for min. 1 s and max. 5 s.</p> <ul style="list-style-type: none"> <li>&gt; The unit is in the adjustment mode.</li> <li>&gt; The green LED is lit permanently.</li> </ul> <p>For the output function "NC" the yellow LED is lit additionally.</p> <ul style="list-style-type: none"> <li>&gt; The unit is in the operating mode.</li> </ul>
--	---



The sensor is operational just with empty adjustment. However, it is recommended to carry out a "full adjustment" with the active zone being completely covered after empty adjustment. On the basis of the values for the empty state / full state the internal microprocessor determines the optimum position of the switching thresholds between the two states. Using both adjustment criteria (empty and full adjustment) results in the maximum operational reliability for the application. For empty adjustment the internal microprocessor generates 2 values.

The first value corresponds to the sensor signal measured in the empty state. The second value is an assumed measured value for the full state. It is calculated from the just measured empty state and a factory signal pre-set. For full adjustment this second value is replaced by a real measured value.

### 6.1.2 Full adjustment

- ▶ After empty adjustment the full state is to be achieved, if possible.
- > The unit switches.

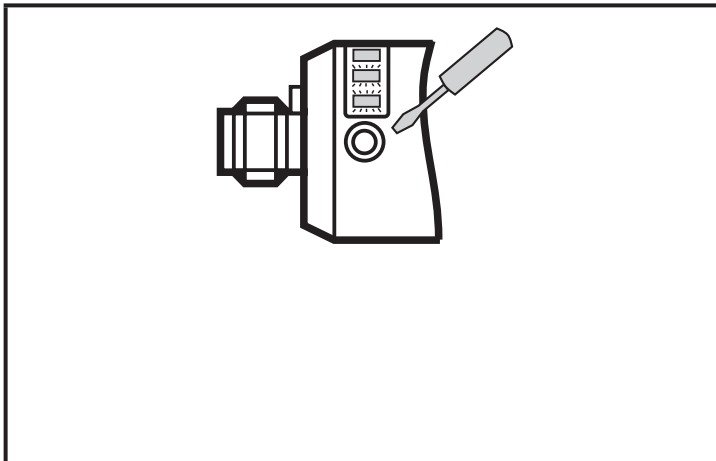

- ▶ Press the programming button 5...10 s.
  - > The green LED first flashes slowly (about 1 Hz), after 5 s it flashes double as quickly (about 2 Hz).
  - > The unit is in the adjustment mode.
  - > The green LED is lit permanently.
- For the output function "NC" the yellow LED is lit additionally.
- > The unit is in the operating mode.

The full adjustment can be repeated as often as you like. The stored value for the empty state is not overwritten by the full adjustment. After a new empty adjustment both values are automatically set again, the values last defined are overwritten.



Always carry out the empty adjustment first, then, if necessary, the full adjustment!

### 6.1.3 Locking

Protect the stored adjustment values against unauthorised programming.



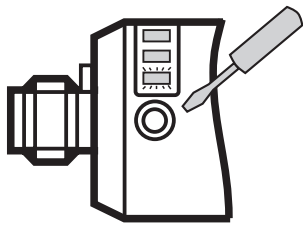

Factory setting: not locked.

- ▶ Press the programming button for min. 10 s.
- > The green LED first flashes slowly (about 1 Hz), after 5 s more quickly (about 2 Hz), after 10 s it goes out.
- > The unit is locked.

▶ Release the programming button.

- > The unit is locked, all programming functions are inactive.
- > The unit returns to the operating mode.

If this operation starts from the locked state, the green LED goes out briefly but then does not react any more.

#### 6.1.4 Unlocking

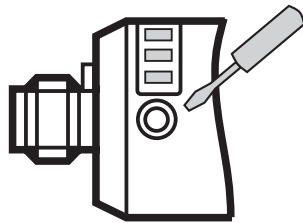

- ▶ Press the programming button for min. 10 s.
- > The green LED goes out briefly, then lights again and goes out after 10 s.
- > The unit is unlocked again and the LEDs indicate the current operating state.

▶ Release the programming button.

- > The unit is unlocked and all programming functions are active again.

#### 6.1.5 Error messages

If empty or full adjustment cannot be made, the red LED flashes quickly at about 8 Hz after the adjustment attempt (adjustment error).

- ▶ Press the programming pushbutton once or switch the operating voltage off and on again.
- > The error message is deleted. The measured values successfully read so far remain unchanged.

Reasons for an error message

- The signal difference between the empty and full state is too small (e.g. empty and full adjustment without sufficient change of the level).
- The signal change between the empty and full state is in the wrong order (e.g. empty adjustment in the full state and then full adjustment in the empty state).

- Empty adjustment outside the operating range (e.g. empty adjustment in case of direct contact with an electrically grounded medium, e.g. if the active zone is immersed in water).
- ▶ Repeat the adjustment for error correction.

#### Further errors

- Electronic fault or sensing zone of the unit damaged.
- Internal fault
- ▶ Switch the operating voltage off and on again.
- > The error is deleted.

## 7 Operation

Check whether the unit operates correctly. To do so, bring about a sensor response by taking suitable measures.

Indication by LEDs and function check output:

LED green	ON = unit is ready for operation
	flashes slowly (1 Hz) = adjustment mode empty state
	flashes quickly (2 Hz) = adjustment mode full state
	OFF = locking mode
LED yellow	OFF = switching output disabled
	ON = switching output enabled
LED red and function check output	flashes quickly (8 Hz) or 8 Hz signal of the function check output = adjustment error, internal fault
	ON = close to reaching the switching threshold
LEDs yellow + red together	flashes quickly (2 Hz) simultaneously = short circuit in the switching output



The red LED and the function check output are briefly active during the change between "medium not present" and "medium present". This can occur in particular if the level changes very slowly and is no error message meaning a fault in the unit.

## **8 Maintenance, repair and disposal**

The operation of the unit is maintenance-free.

For a correct function keep the sensing face and the clear space free of metal deposits and foreign bodies, in particular for an installation with the sensing face facing upwards.

After use dispose of the unit in an environmentally friendly way in accordance with the applicable national regulations.

## **9 Technical data**

Technical data and further information at

[www.ifm.com](http://www.ifm.com) → Select your country → Data sheet search