



ifm electronic



Montage- und Installationshinweise

Mounting and installation instructions

ecomat 100[®]

Neigungssensor
Inclination sensor

EC2082

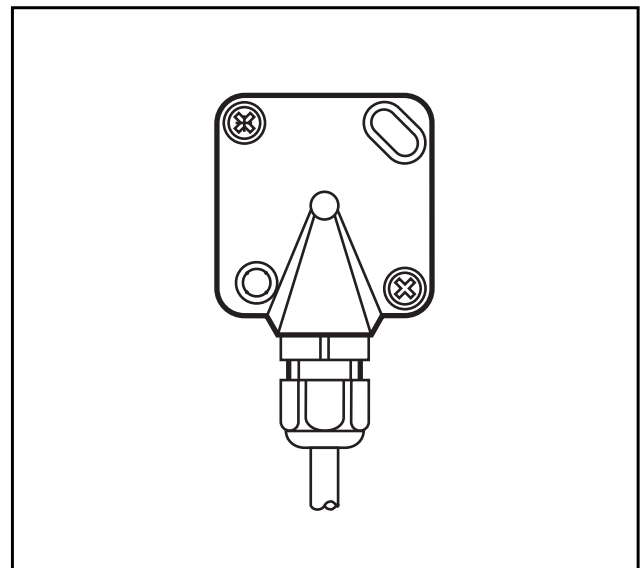

Sachnr. 7390445/00 | 03/2016



DEUTSCH

ENGLISH

Safety instructions



This description is part of the sensors. It contains texts and drawings concerning the correct handling of the sensor and must be read before installation or use.

Observe the information of the description. Non-observance of the notes, operation which is not in accordance with use as prescribed below, wrong installation or handling can result in serious harm concerning the safety of persons and plant.

The instructions are for authorised persons according to the EMC and low voltage directives. The controllers must be installed and commissioned by a skilled electrician (service technician, etc.).

If the sensor is not supplied by the mobile on-board system (12/24 V battery operation) it must be ensured that the external voltage is generated and supplied according to the criteria for safety extra-low voltage (SELV).



If the sensor is operated with an AC/DC power converter, it must be ensured that this AC/DC power converter complies with the requirements of the standard 61000-6-2 and limits the test interference to a value of ± 0.05 kV.

The wiring of all signals in connection with the SELV circuit of the unit must also comply with the SELV criteria (safe extra-low voltage, safe electrical separation from other electric circuits).

If the supplied SELV voltage has an external connection to ground the responsibility lies with the user and the respective national regulations for installation must be complied with. All statements in these operating instructions refer to the sensors the SELV voltage of which is not grounded.

Only the signals indicated in the technical data or on the type label may be supplied to the connection terminals or wires.

In case of malfunctions or uncertainties please contact the manufacturer. Tampering with the sensor can lead to considerable risks for the safety of persons and plant. It is not permitted and leads to the exclusion of any liability and warranty claims.

Contents

Technical data	page 7
Dimensions	page 7
Mounting	page 8
Electrical connection	page 8
Characteristics of the output function	page 9
Maintenance, repair and disposal	page 9
Declaration of conformity	page 9

Technical data

	EC2082
Order no.	
Operating voltage	20...30 V DC
Current consumption max.	< 35 mA
Analogue output	current output 4...20 mA DC
Output function	$I_a = 12 \text{ mA} + \sin(\alpha) \times 8 \text{ mA}$
Load impedance	200...400 Ω (to signal ground at the output)
Short-circuit protection	to U_B and to ground
Reverse polarity / overload protection	• / •
Angular range (α)	$\pm 90^\circ$
Zero error	< $\pm 7^\circ$ (the zero error can be reduced by $\pm 4^\circ$ by adjustment of the unit)
Operating temperature	-30...+85°C
Protection	IP 67, II
Housing material	plastic (Nyrol, PPE)
Connection	M12 connector; 4-pole; 0.2 m cable

Dimensions

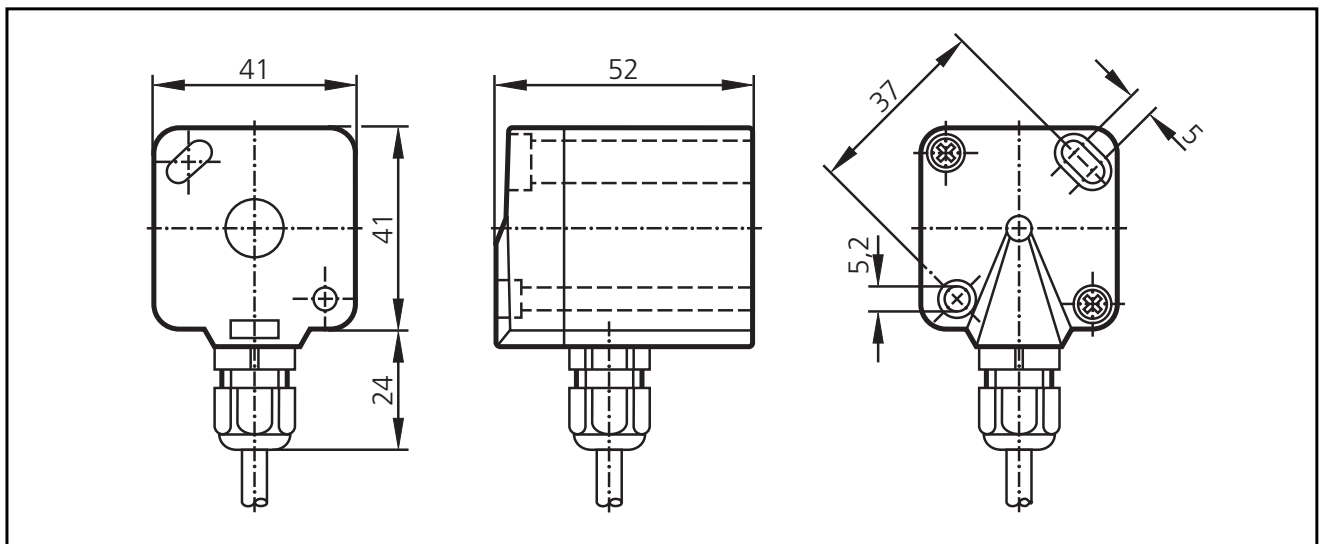

Mounting

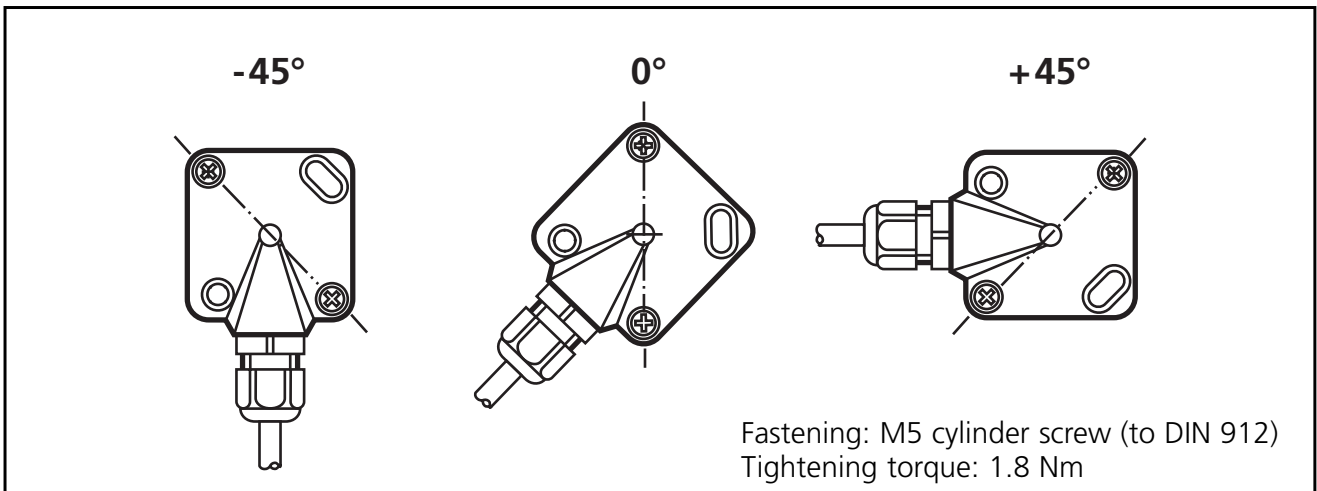

Electrical connection

Description	Pin	Potential
Operating voltage	1	20...30 V DC
Ground	3	GND
Analogue output	4	4...20 mA DC

To protect the whole system the supply voltage must be protected with max. 0.5A.

The signal cable length is max. 30 m.

To ensure the accuracy of the inclination information additional screening may be necessary.

Characteristic of the output function

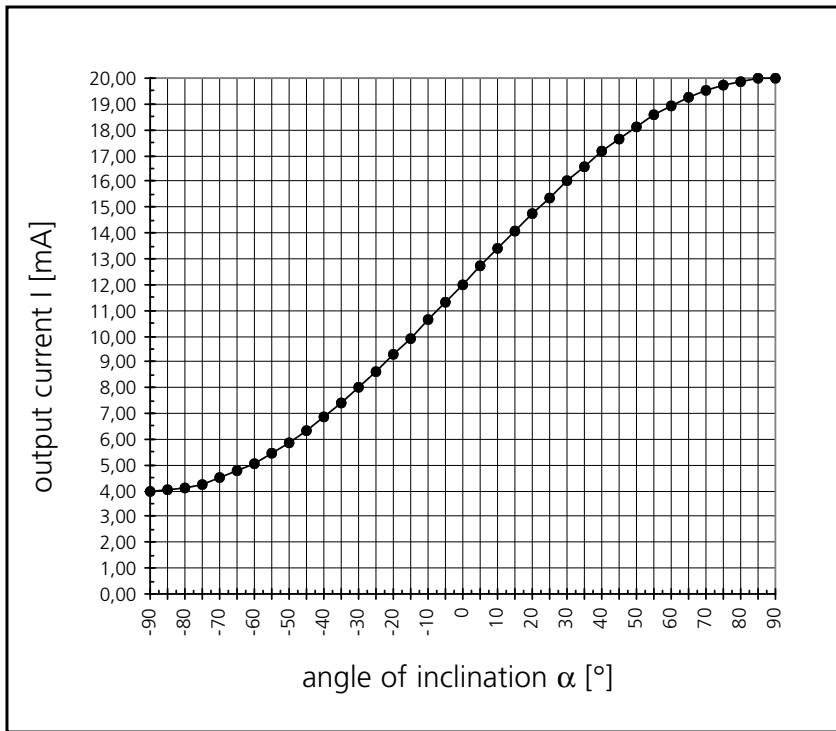

Angle and output values:

α [°]	I [mA]	α [°]	I [mA]
-90	4,00	5	12,70
-85	4,02	10	13,39
-80	4,12	15	14,07
-75	4,27	20	14,74
-70	4,48	25	15,38
-65	4,75	30	16,00
-60	5,07	35	16,59
-55	5,45	40	17,14
-50	5,87	45	17,66
-45	6,34	50	18,13
-40	6,86	55	18,55
-35	7,41	60	18,93
-30	8,00	65	19,25
-25	8,62	70	19,52
-20	9,26	75	19,73
-15	9,93	80	19,88
-10	10,61	85	19,97
-5	11,30	90	20,00
0	12,00		

Maintenance, repair and disposal

As the inclination sensor does not contain any components which must be maintained by the user, the housing must not be opened. The sensor may only be maintained by the manufacturer. The disposal must be carried out according to the corresponding national environmental regulations.

Declaration of conformity

The CE marking is applied on the basis of the EMC directive EMC 2004/108/EEC, implemented in the standards EN 61000-6-2: 2005 and EN 61000-6-4: 2007.