

ifm electronic

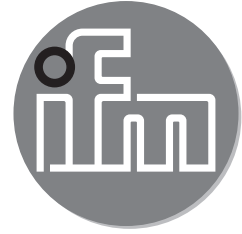

Installation instructions
Progressive ring fitting

UK

80232423 / 00 09 / 2015

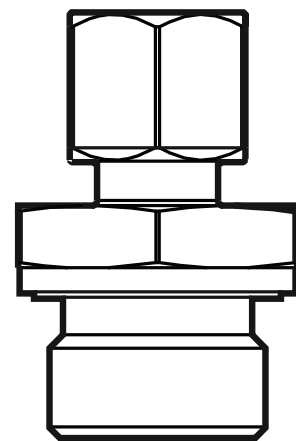

The progressive ring fitting consists of the three parts screw fitting (A), cutting ring (B) and coupling nut (C).

1. Insert the screw fitting (A) in the process connection and tighten. Use a seal if required by the application.

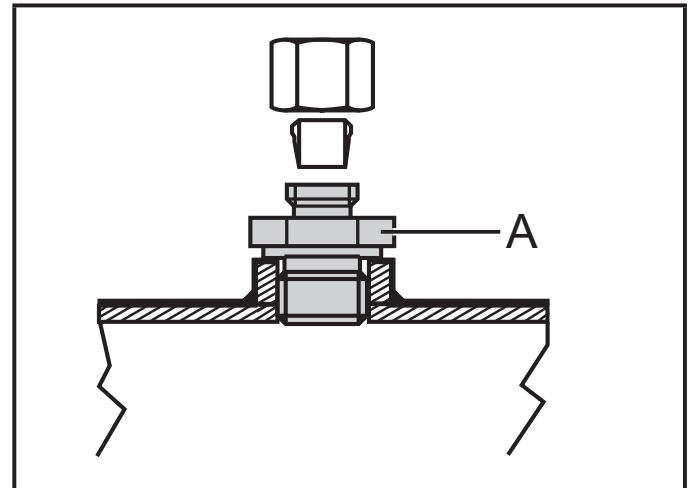

 When using welding adapters:

- welding operation to be carried out by qualified personnel only. Careful execution in accordance with the state of technology:
- During welding and the following cooling phase neither sensor nor progressive ring fitting must be in place.
- The surfaces must be free from any soiling.
- Welding materials must be suitable for the adapter and wall material.

2. Insert the cutting ring (B). The tapered end must face towards the cone.

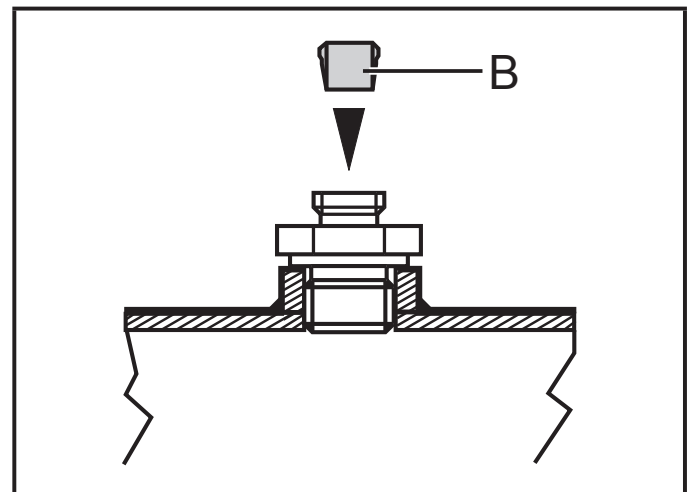

3. Fit the coupling nut (C) and insert the sensor (D).

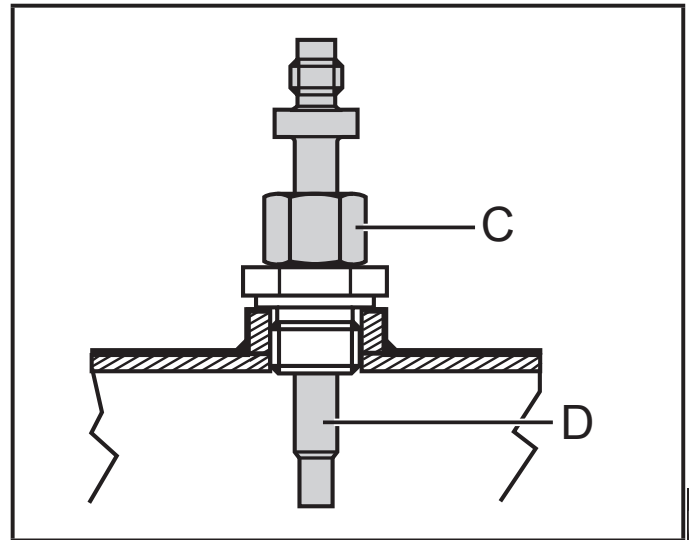

4. Tighten the coupling nut manually and mark its position with a line (E).

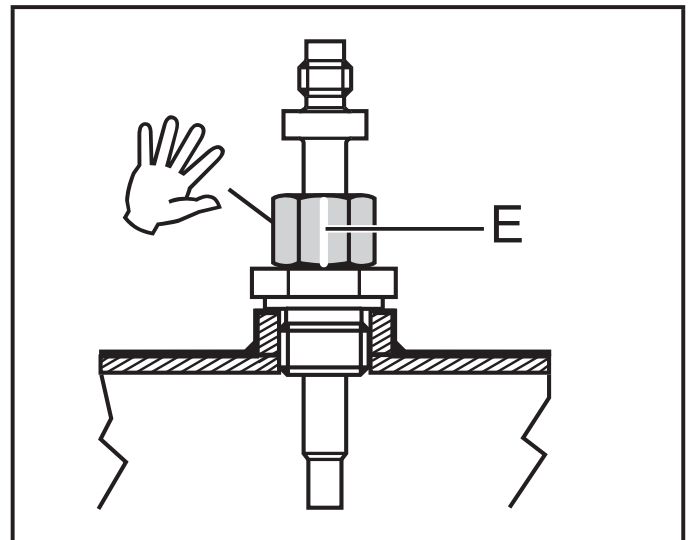

5. Adjust the sensor to the required installation depth. Hold it and tighten the coupling nut by 1 ¼ turns with a tool.

- > The cutting ring is now firmly connected to the sensor probe.



Recommended installation depth for the measuring probe: middle of the pipe.

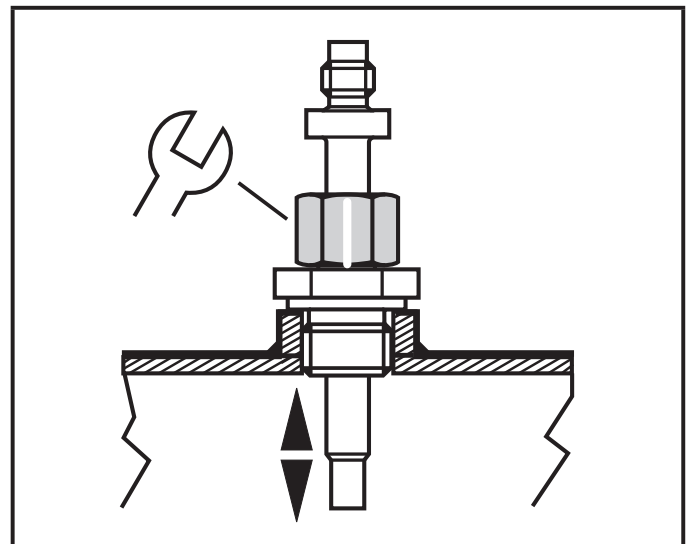

Repeated installation

You can remove the sensor e.g. to clean the tip.

- After that, reinsert the sensor and tighten the coupling nut without applying too much force.