

BUS M30M1-XC-35/340-S92K BUS003T

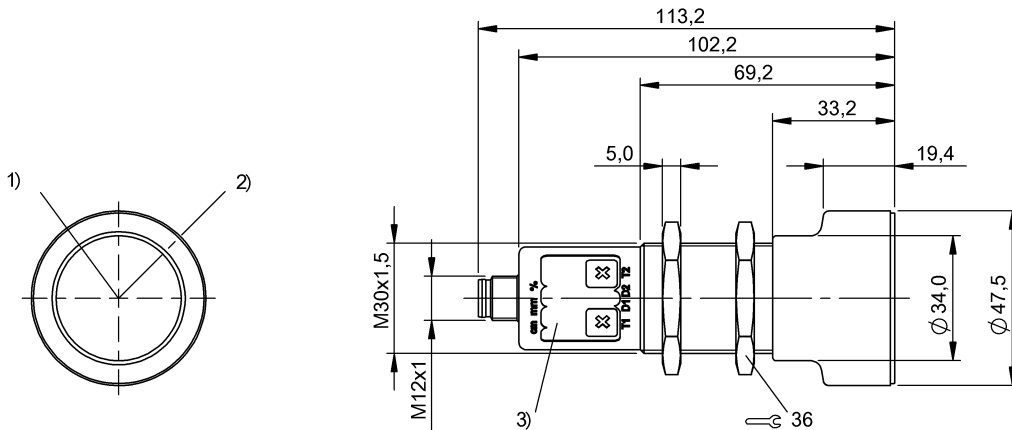

1) Ultrasonic transducer axis 2) Exit direction 90° connector 3) Display and control panel



Display/Operation

Adjuster	Key (2x)
Setting	Filter strength (10 levels) Segment displ. bright/dark/off Synchronous/Multiplex mode Response delay 0 to 20 s Foreground suppression range Multiplex sensor address Sensor calibration Temperature comp. on/off Output curve rising/falling Analog output U/I/Auto Segment display mode Synchronization on/off Multiplex speed Measured value filter Hysteresis Detection range (3 levels) Teach-in mode display/button Factory setting (Reset) Key disable on/off Operating mode Switching distance, 2 values Normally open/Normally closed Output curve window

Output characteristic	linear rising/falling
Rated operating voltage Ue DC	24 V
Synchronization	internal, max. 10 sensors
Ultrasonic frequency	120 kHz

Environmental conditions

Ambient temperature	-25...70 °C
Ambient temperature max.	70 °C
Ambient temperature min.	-25 °C
Protection type IEC 60529	IP67
Storage temperature	-40...85 °C

Functional safety

Diagnostic coverage	0 %
Functional safety	no
Mission Time	10 a

General data

Application	Distance measurement
Approval/Conformity	CE
Operating mode	Analog measurement (output curve)
Series	M30M1

Electrical connection

Connection	M12x1-Male
Polarity reversal protected	yes
Short-circuit protection	yes

Electrical data

Current draw max.	80 mA
Load resistance RL max. (Analog I)	500 Ohm at UB 20 V 100 Ohm at UB 20 V
Load resistance RL min. (Analog V)	100 kOhm at UB 15 V
MTTF (40 °C)	178 a
Operating voltage Ub	9...30 VDC

Material

Housing material	Brass PBTTTPU
Material sensing surface	PU foamEpoxy resinGlass
Surface protection	nickel plates

BUS M30M1-XC-35/340-S92K BUS003T

Mechanical data

Fastening detail Nut M30x1.5

Output/Interface

Analog output Analog, voltage/analog, current, 0...10 V/4...20 mA
 Input function Synchronization signal

Range/Distance

Measuring range 350...5000 mm
 Range 350...5000 mm

Rated operating distance S_n 3400 mm
 Repeat accuracy $\pm 0.15\%$ FS
 Resolution ≤ 0.180 mm

Remarks

The sensor is functional again after the overload has been eliminated.
 Reference object for S_n : Tube $\varnothing 27$ mm. Max. range applies to aligned plate.
 Do not press key using a pointed tool.
 Order accessories separately.
 For additional information, refer to user's guide.

For further information on MTTF/B10d, please refer to the MTTF / B10d Certificate.

Specification of the MTTF value and the B10d value do not represent any binding quality and/or life expectancy guarantees.

Pin Assignment

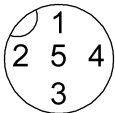

Wiring Diagramm

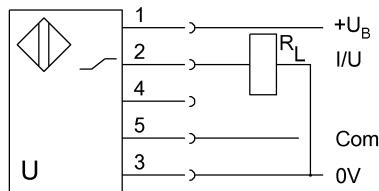

Additional View

