

BTL7-A/C/E/G5 _ _ -M _ _ _ _ -H/W(8)-S32/S115/ _ _ _

User's Guide

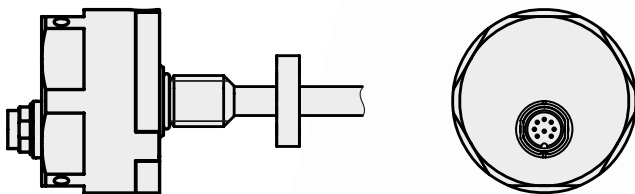

www.balluff.com

1	Notes to the user	5
1.1	Validity	5
1.2	Symbols and conventions	5
1.3	Scope of delivery	5
1.4	Approvals and markings	5
2	Safety	6
2.1	Intended use	6
2.2	General safety notes for the linear encoder	6
2.3	Explanation of the warnings	6
2.4	Disposal	6
3	Construction and function	7
3.1	Construction	7
3.2	Function	7
4	Installation and connection	8
4.1	Installation guidelines	8
4.2	Preparing for installation	8
4.3	Installing the transducer	9
4.3.1	Installation recommendation for hydraulic cylinders	9
4.4	Electrical connection	10
4.4.1	Connector S32	10
4.4.2	Connector S115	10
4.4.3	Cable connection	11
4.5	Shielding and cable routing	11
5	Startup	12
5.1	Starting up the system	12
5.2	Operating notes	12
6	Calibration procedure	13
6.1	Programming inputs	13
6.2	Calibration procedure notes	13
6.3	Calibration procedure overview	14
6.3.1	Teach-in	14
6.3.2	Adjusting	15
6.3.3	Reset	15
7	Teach-in	16
8	Adjusting	17
9	Resetting all values (reset)	19
10	Technical data	20
10.1	Accuracy	20
10.2	Ambient conditions	20
10.3	Supply voltage (external)	20
10.4	Output	20
10.5	Input	20
10.6	Dimensions, weights	21

11	Accessories	22
11.1	Magnets	22
11.2	Mounting nut	22
11.3	Connectors and cables	23
11.3.1	BKS-S32/S33M-00, freely configurable	23
11.3.2	BKS-S232/S233-PU-__, preassembled	23
11.3.3	BKS-S115/S116-PU-__, preassembled	24
11.4	Calibration box	24
12	Type code breakdown	25
13	Appendix Section	26
13.1	Converting units of length	26
13.2	Part label	26

BTL7-A/C/E/G5__-M____-H/W(8)-S32/S115/____ Micropulse Transducer - Rod Style

1

Notes to the user

1.1 Validity

This guide describes the construction, function and setup options for the BTL7 Micropulse Transducer with analog interface. It applies to types

BTL7-A/C/E/G5__-M____-H/W(8)-S32/S115/____
(see Type code breakdown on page 25).

The guide is intended for qualified technical personnel. Read this guide before installing and operating the transducer.

1.2 Symbols and conventions

Individual **instructions** are indicated by a preceding triangle.

► Instruction 1

Action sequences are numbered consecutively:

1. Instruction 1
2. Instruction 2



Note, tip

This symbol indicates general notes.

1.3 Scope of delivery

- BTL7 transducer
- Condensed guide



The magnets are available in various models and must be ordered separately.



The CE Mark verifies that our products meet the requirements of the current EMC Directive.

The transducer meets the requirements of the following product standard:

- EN 61326-2-3 (noise immunity and emission)

Emission tests:

- RF emission
EN 55011

Noise immunity tests:

- | | |
|--|------------------|
| - Static electricity (ESD)
EN 61000-4-2 | Severity level 3 |
| - Electromagnetic fields (RFI)
EN 61000-4-3 | Severity level 3 |
| - Electrical fast transients (burst)
EN 61000-4-4 | Severity level 3 |
| - Surge
EN 61000-4-5 | Severity level 2 |
| - Conducted interference induced
by high-frequency fields
EN 61000-4-6 | Severity level 3 |
| - Magnetic fields
EN 61000-4-8 | Severity level 4 |



More detailed information on the guidelines, approvals, and standards is included in the declaration of conformity.

1.4 Approvals and markings



UL approval ¹⁾
File no.
E227256

¹⁾ Not for BTL7-...-F_-, BTL7-...-FA_-

US Patent 5 923 164

The US patent was awarded in connection with this product.

2

Safety

2.1 Intended use

The Micropulse Transducer, together with a machine controller (e.g. PLC), comprises a linear encoder. It is intended to be installed into a machine or system. Flawless function in accordance with the specifications in the technical data is ensured only when using original BALLUFF accessories. Use of any other components will void the warranty.

Opening the transducer or non-approved use are not permitted and will result in the loss of warranty and liability claims against the manufacturer.

2.2 General safety notes for the linear encoder

Installation and **startup** may only be performed by trained specialists with basic electrical knowledge.

Qualified personnel are those who can recognize possible hazards and institute the appropriate safety measures due to their professional training, knowledge, and experience, as well as their understanding of the relevant regulations pertaining to the work to be done.

The **operator** is responsible for ensuring that local safety regulations are observed.

In particular, the operator must take steps to ensure that a defect in the linear encoder will not result in hazards to persons or equipment.

If defects and unresolvable faults occur in the transducer, it should be taken out of service and secured against unauthorized use.

2.3 Explanation of the warnings

Always observe the warnings in these instructions and the measures described to avoid hazards.

The warnings used here contain various signal words and are structured as follows:

SIGNAL WORD
Hazard type and source Consequences if not complied with ▶ Measures to avoid hazards

The individual signal words mean:

NOTICE! Identifies a hazard that could damage or destroy the product .
 DANGER The general warning symbol in conjunction with the signal word DANGER identifies a hazard which, if not avoided, will certainly result in death or serious injury .

2.4 Disposal

- ▶ Observe the national regulations for disposal.

BTL7-A/C/E/G5__-M____-H/W(8)-S32/S115/____ Micropulse Transducer - Rod Style



Construction and function

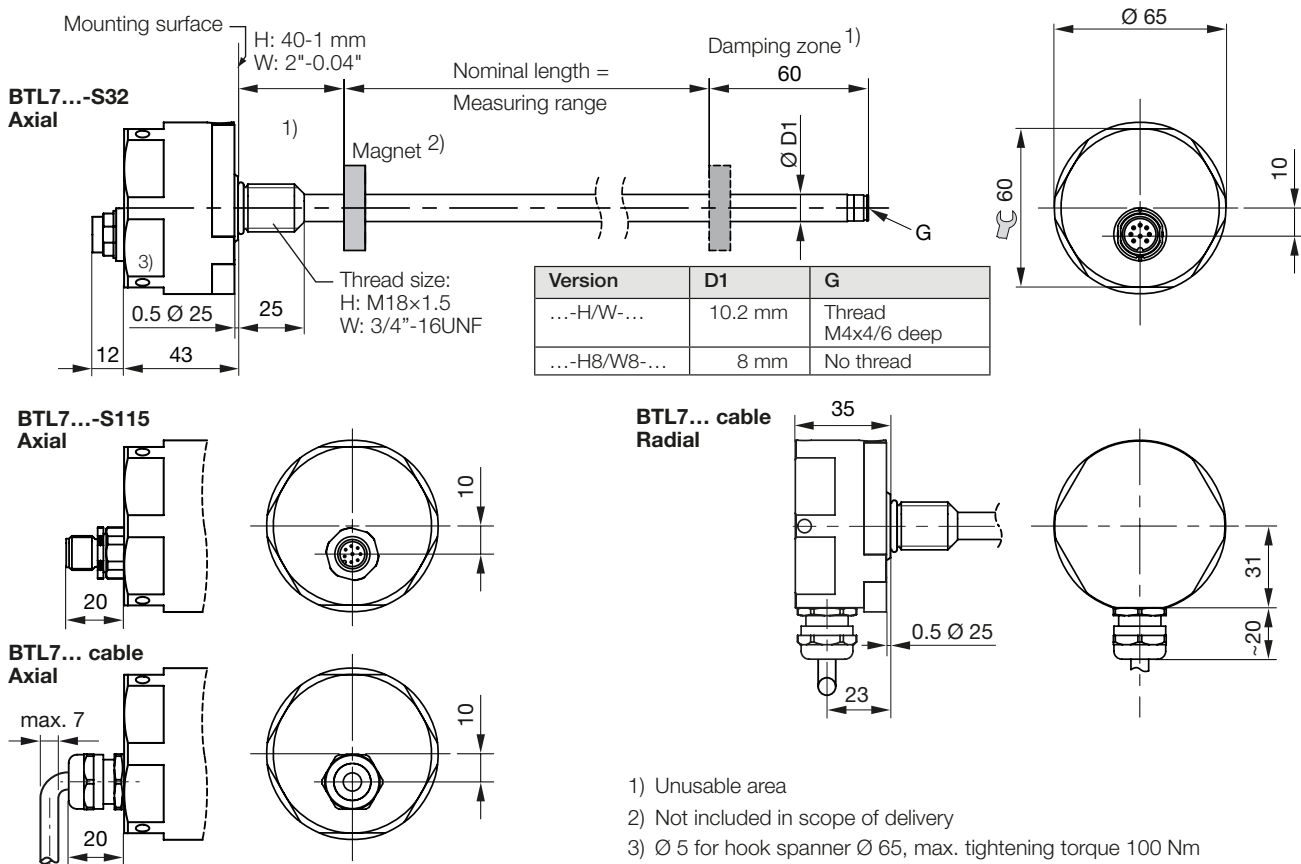

Fig. 3-1: BTL7-...-H/W(8)-... transducer, construction and function

3.1 Construction

Electrical connection: The electrical connection is made via a cable or a connector (see Type code breakdown on page 25).

Housing: Housing containing the processing electronics.

Mounting thread: We recommend assembling these transducers on the mounting thread:

- BTL7-...-H: M18x1.5
- BTL7-...-W: 3/4"-16UNF

The transducer with Ø 10.2 mm has an additional thread at the end of the rod to support larger nominal lengths.

Magnet: Defines the position to be measured on the waveguide. Magnets are available in various models and must be ordered separately (see Accessories on page 22).

Nominal length: Defines the available measuring range. Rods with various nominal lengths from 25 mm to 7620 mm are available depending on the version:

- Ø 10.2 mm: Nominal length from 25 mm to 7620 mm
- Ø 8 mm: Nominal length from 25 mm to 1016 mm

Damping zone: Area at the end of the rod that cannot be used for measurements, but which may be passed over.

3.2 Function

The Micropulse Transducer contains the waveguide which is protected by an outer stainless steel tube (rod). A magnet is moved along the waveguide. This magnet is connected to the system part whose position is to be determined.

The magnet defines the position to be measured on the waveguide.

An internally generated INIT pulse interacts with the magnetic field of the magnet to generate a torsional wave in the waveguide which propagates at ultrasonic speed.

The component of the torsional wave which arrives at the end of the waveguide is absorbed in the damping zone to prevent reflection. The component of the torsional wave which arrives at the beginning of the waveguide is converted by a coil into an electrical signal. The travel time of the wave is used to calculate the position. Depending on the version, this information is made available as a voltage or current output with a rising or falling gradient.

4

Installation and connection

4.1 Installation guidelines

Non-magnetizable material

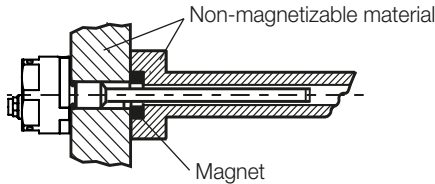

¹⁾ Min. Ø D2 = Minimum diameter of the bore (see Tab. 4-1)

Fig. 4-1: Installation variant in non-magnetizable material

Magnetizable material

If using magnetizable material, the transducer must be protected against magnetic interference through suitable measures (e.g. spacer ring made of non-magnetizable material, a suitable distance from strong external magnetic fields).

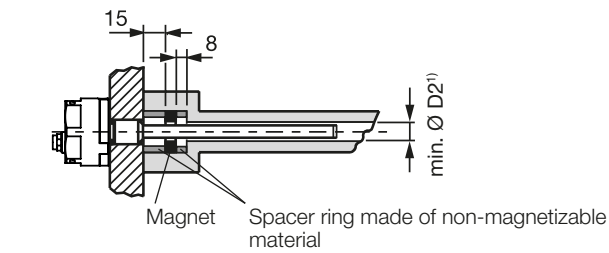
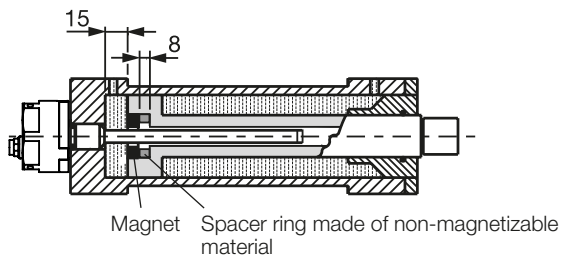

¹⁾ Min. Ø D2 = Minimum diameter of the bore (see Tab. 4-1)

Fig. 4-2: Installation in magnetizable material

Tube diameter	Bore diameter D2
10.2 mm	At least 13 mm
8 mm	At least 11 mm

Tab. 4-1: Bore diameter if installed in a hydraulic cylinder

4.2 Preparing for installation

Installation note: We recommend using non-magnetizable material to mount the transducer and magnet.

Horizontal assembly: For horizontal assembly with nominal lengths > 500 mm, support the rod and tighten it at the end if necessary (only possible with a diameter of 10.2 mm).

Hydraulic cylinder: If installed in a hydraulic cylinder, ensure that the minimum value for the bore diameter of the support piston is complied with (see Tab. 4-1).

Mounting hole: The transducer comes with an M18x1.5 (ISO) or 3/4"-16UNF (SAE) mounting thread. Depending on the version, a mounting hole must be made before assembly.

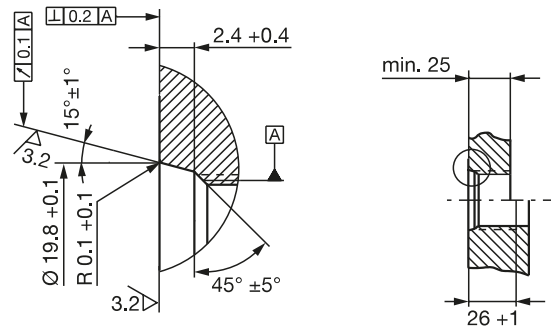

Fig. 4-3: Mounting hole M18x1.5 per ISO 6149 O-ring 15.4x2.1

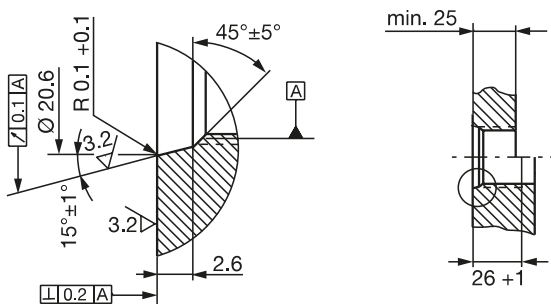

Fig. 4-4: Mounting hole 3/4"-16UNF per SAE J475 O-ring 15.3x2.4

Magnet: Various magnets are available for the BTL7 transducer (See Accessories on page 22).

4

Installation and connection (continued)

4.3 Installing the transducer

NOTICE!

Interference in function

Improper installation can compromise the function of the transducer and result in increased wear.

- ▶ The mounting surface of the transducer must make full contact with the supporting surface.
- ▶ The bore must be perfectly sealed (O-ring/flat seal).

- ▶ Make a mounting hole with thread (possibly with countersink for the O-ring) acc. to Fig. 4-3 or Fig. 4-4.
- ▶ Screw the transducer with mounting thread into the mounting hole (max. torque 100 Nm).



Radial cable outlet

During installation, the direction of the cable outlet is determined by the thread.

- ▶ Install the magnet (accessories).
- ▶ From 500 mm nominal length: support the rod and tighten it at the end if necessary (only possible with a diameter of 10.2 mm).



Suitable nuts for the mounting thread are available as accessories (see page 22).

4.3.1 Installation recommendation for hydraulic cylinders

If you seal the hole with a flat seal, the max. operating pressure will be reduced in accordance with the larger pressurized surface.

If installing horizontally in a hydraulic cylinder (nominal lengths > 500 mm), we recommend affixing a slide element to protect the rod end from wear.



Dimensioning of the detailed solutions is the responsibility of the cylinder manufacturer.

The slide element material must be suitable for the appropriate load case, medium used, and application temperatures. E.g. Torlon, Teflon or bronze are all possible materials.

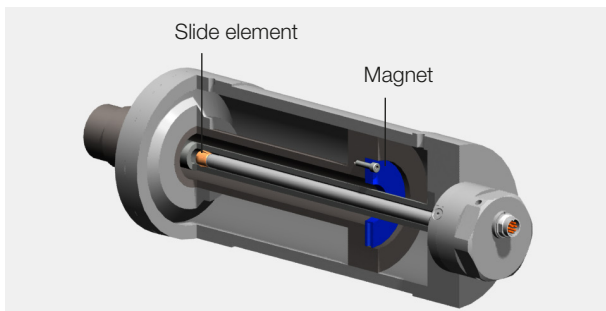

Fig. 4-5: Example 1, transducer installed with slide element

The slide element can be screwed on or bonded.

- ▶ Secure the screws so they cannot be loosened or lost.
- ▶ Select a suitable adhesive.

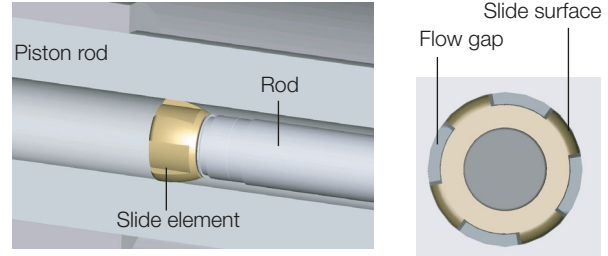

Fig. 4-6: Detailed view and top view of slide element

There must be a gap between the slide element and piston bore that is sufficiently large for the hydraulic oil to flow through.

Options for fixing the magnet:

- Screws
- Threaded ring
- Press fitting
- Notches (center punching)



If installed in a hydraulic cylinder, the magnet should not make contact with the rod.

The hole in the spacer ring must ensure optimum guidance of the rod by the slide element.

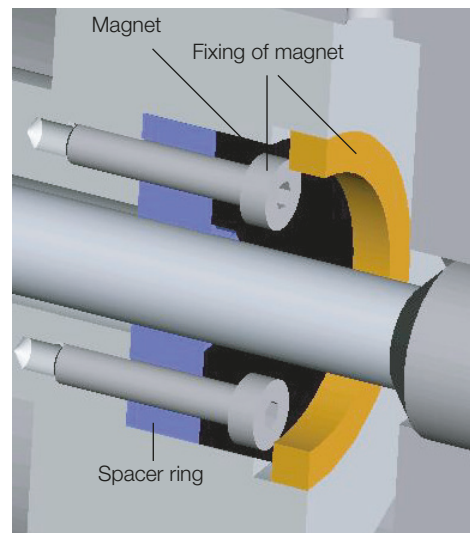

Fig. 4-7: Fixing the magnet

An example of how to install the transducer with a supporting rod is shown in Fig. 4-8 on page 10.

4

Installation and connection (continued)

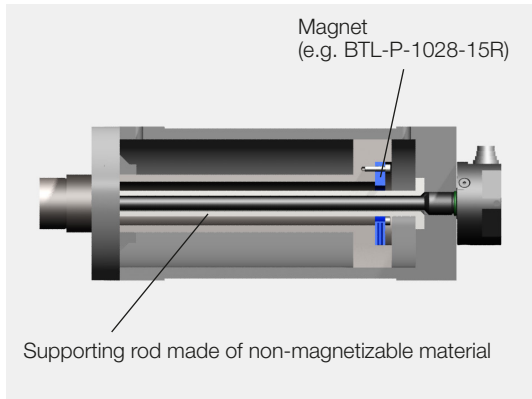

Fig. 4-8: Example 2, transducer installed with supporting rod

4.4 Electrical connection

Depending on the model, the electrical connection is made using a cable or a connector (BTL7...-S32, BTL7...-S115). The connection or pin assignments for the respective version can be found in Tables 4-2 to 4-4.



Note the information on shielding and cable routing on page 11.

4.4.1 Connector S32

Pin	-A510	-G510	-C500	-C570	-E500	-E570
1	Not used ¹⁾		0...20 mA	20...0 mA	4...20 mA	20...4 mA
2	0 V					
3	10...0 V	10...-10 V	10...0 V ³⁾			
4	La (programming input)					
5	0...10 V	-10...10 V	0...10 V ³⁾			
6	GND ²⁾					
7	10...30 V					
8	Lb (programming input)					

¹⁾ Unassigned leads can be connected to the GND on the controller side but not to the shield.

²⁾ Reference potential for supply voltage and EMC-GND.

³⁾ The voltage outputs may exhibit a minimal offset to the harmonized current output.

Tab. 4-2: Connection assignment BTL7...-S32

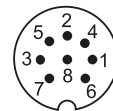

Fig. 4-9: Pin assignment of S32 (view from above on transducer), 8-pin M16 circular plug

4.4.2 Connector S115

Pin	-A510	-G510	-C500	-C570	-E500	-E570
1	0 V (pin 3)		Not used ¹⁾			
2	0 V (pin 5)					
3	10...0 V	10...-10 V	Not used ¹⁾			
4	La (programming input)					
5	0...10 V	-10...10 V	0...20 mA	20...0 mA	4...20 mA	20...4 mA
6	GND ²⁾					
7	10...30 V					
8	Lb (programming input)					

¹⁾ Unassigned leads can be connected to the GND on the controller side but not to the shield.

²⁾ Reference potential for supply voltage and EMC-GND.

Tab. 4-3: Connection assignment BTL7...-S115

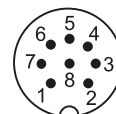

Fig. 4-10: Pin assignment of S115 (view from above on transducer), 8-pin M12 circular plug

4

Installation and connection (continued)

4.4.3 Cable connection

Cable color	-A510	-G510	-C500	-C570	-E500	-E570
YE yellow	Not used ¹⁾		0...20 mA	20...0 mA	4...20 mA	20...4 mA
GY gray	0 V					
PK pink	10...0 V	10...-10 V	10...0 V ³⁾			
RD red	La (programming input)					
GN green	0...10 V	-10...10 V	0...10 V ³⁾			
BU blue	GND ²⁾					
BN brown	10...30 V					
WH white	Lb (programming input)					

¹⁾ Unassigned leads can be connected to the GND on the controller side but not to the shield.

²⁾ Reference potential for supply voltage and EMC-GND.

³⁾ The voltage outputs may exhibit a minimal offset to the harmonized current output.

Tab. 4-4: Cable assignment BTL7... cable

4.5 Shielding and cable routing



Defined ground!

The transducer and the control cabinet must be at the same ground potential.

Shielding

To ensure electromagnetic compatibility (EMC), observe the following:

- Connect transducer and controller using a shielded cable.
Shielding: Braided copper shield with minimum 85%.
- Connector version: Shield is internally connected to connector housing.
- Cable version: On the transducer side, the cable shielding is connected to the housing. Ground the cable shielding on the controller side (connect with the protective earth conductor).

Magnetic fields

The linear encoder is a magnetostrictive system. It is important to maintain adequate distance between the transducer/holding cylinder and strong, external magnetic fields.

Cable routing

Do not route the cable between the transducer, controller, and power supply near high voltage cables (inductive stray noise is possible).

The cable must be routed tension-free.

Bending radius for fixed cable

The bending radius for a fixed cable must be at least five times the cable diameter.

Cable length

BTL7-A/G	Max. 30 m ¹⁾
BTL7-C/E	Max. 100 m ¹⁾

¹⁾ Prerequisite: Construction, shielding and routing preclude the effect of any external noise fields.

Tab. 4-5: Cable lengths BTL7

5

Startup

5.1 Starting up the system

DANGER

Uncontrolled system movement

When starting up, if the position measuring system is part of a closed loop system whose parameters have not yet been set, the system may perform uncontrolled movements. This could result in personal injury and equipment damage.

- ▶ Persons must keep away from the system's hazardous zones.
- ▶ Startup must be performed only by trained technical personnel.
- ▶ Observe the safety instructions of the equipment or system manufacturer.

1. Check connections for tightness and correct polarity. Replace damaged connections.
2. Turn on the system.
3. Check measured values and adjustable parameters and readjust the transducer, if necessary.



Check for the correct values at the null point and end point, especially after replacing the transducer or after repair by the manufacturer.

5.2 Operating notes

- Check the function of the linear encoder and all associated components on a regular basis.
- Take the linear encoder out of operation whenever there is a malfunction.
- Secure the system against unauthorized use.

6

Calibration procedure

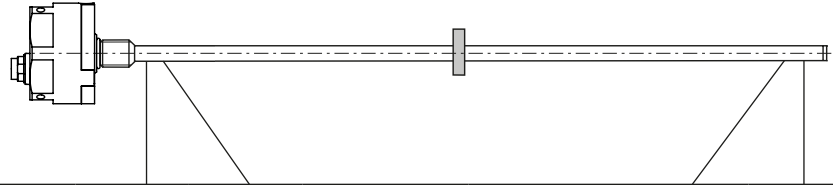

Output gradient	Linear transducer	Unit	Min. value	Null value	Indication for adjustment	Indication for teach-in	End value	Max. value	Error value
Rising	BTL7-A...	V	-0.5	0	2.0	4.0	+10.0	+10.5	+10.5
	BTL7-G...	V	-10.5	-10.0	2.0	4.0	+10.0	+10.5	+10.5
	BTL7-C...	mA	0	0	6.0	12.0	20.0	20.4	20.4
	BTL7-E...	mA	3.6	4.0	6.0	12.0	20.0	20.4	3.6
Falling	BTL7-A...	V	+10.5	+10.0	2.0	4.0	0	-0.5	-0.5
	BTL7-G...	V	+10.5	+10.0	2.0	4.0	-10.0	-10.5	-10.5
	BTL7-C...	mA	20.4	20.0	6.0	12.0	0	0	20.4
	BTL7-E...	mA	20.4	20.0	6.0	12.0	4.0	3.6	3.6

Tab. 6-1: Value table for teach-in and inverting

6.1 Programming inputs

Programming inputs La and Lb must be used in order to make settings. A programming input at 10 to 30 V corresponds to activation (high active). The Balluff BTL7-A-CB02-... adjusting box can be used for this (see Accessories on page 22).



Automatic deactivation!

If no signals are transmitted via the programming inputs for approx. 10 min, programming mode is automatically ended.

Values for null and end point

- Any desired position of the magnet can be used as the null or end point. However, the null and end points may not be reversed.
- The absolute null and end points must lie within the minimum or maximum range of what can be output (see value table).



The last set values are always saved, regardless of whether the setting was ended using the programming inputs or automatically after 10 min have expired.

6.2 Calibration procedure notes

Prerequisites

- Programming inputs are connected.
- The transducer is connected to the system controller.
- Voltage or current values from the transducer can be read (using a multimeter, the system control or the adjusting box).

Value table for teach-in and inverting



The following examples refer to transducers with 0 to 10 V or 4 to 20 mA output.

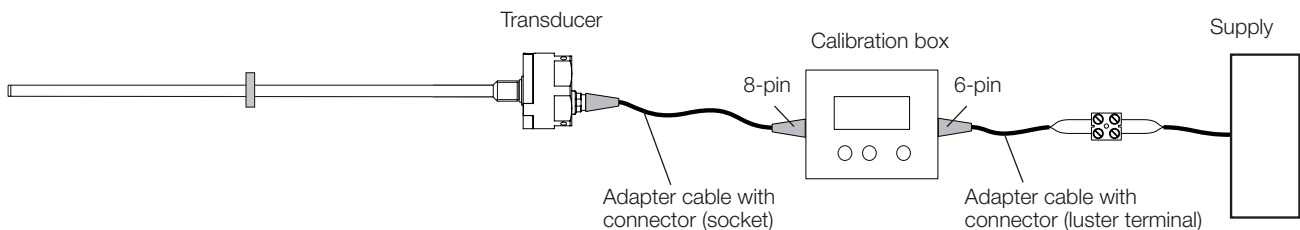

Fig. 6-1: Connecting the BTL7-A-CB02-S... adjusting box

6

Calibration procedure (continued)

6.3 Calibration procedure overview

6.3.1 Teach-in

The factory set null point and end point is replaced by a new null point and end point. The null point and end point can be set separately, the output gradient changes.



The detailed procedure for teach-in is described on page 16.

Steps

- ▶ Move magnet to the new null position.
- ▶ Read new null point by activating the programming inputs.
 - ⇒ The current end point remains the same.

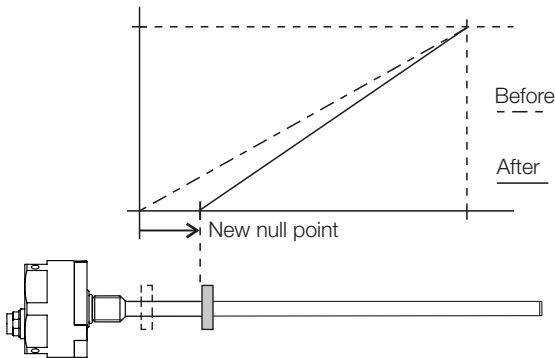

Fig. 6-2: Reading new null point

- ▶ Move magnet to the new end position.
- ▶ Read new end point by activating the programming inputs.
 - ⇒ The current null point remains the same.

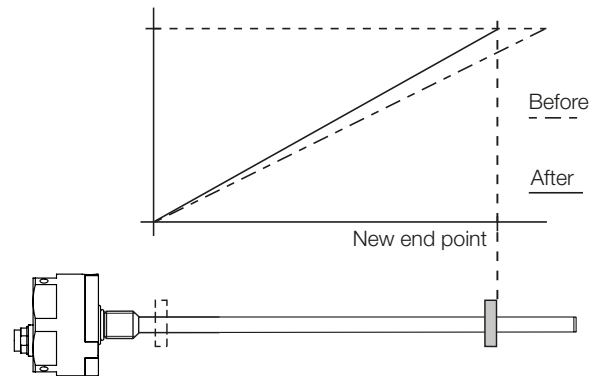

Fig. 6-3: Reading new end point

Only with BTL7-C/E...:

- ▶ The gradient of the current output can be inverted by activating the programming inputs.
 - ⇒ For example, a rising output gradient is changed to a falling gradient. The voltage outputs are not inverted.

6

Calibration procedure (continued)

6.3.2 Adjusting

i The detailed procedure for adjusting is described on page 17 ff.

The factory set null point and end point is replaced by a new start point and end point and the associated output values can be adjusted. The start and end values can be adjusted as you like up to the limits.

i Adjustment is possible from serial number 120615000xxxxx xx onwards.

Steps

- ▶ Move magnet to the new start position.
- ▶ Read new start point by pressing the buttons.
- ▶ Set the new start value by pressing the buttons.

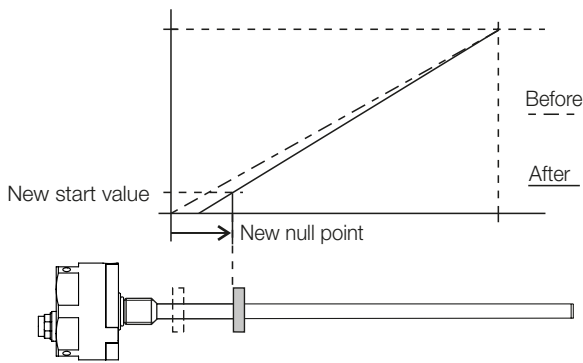

Fig. 6-4: Adjust a new start value

- ▶ Move magnet to the new end position.
- ▶ Read new end point by pressing the buttons.
- ▶ Set the new end value by pressing the buttons.

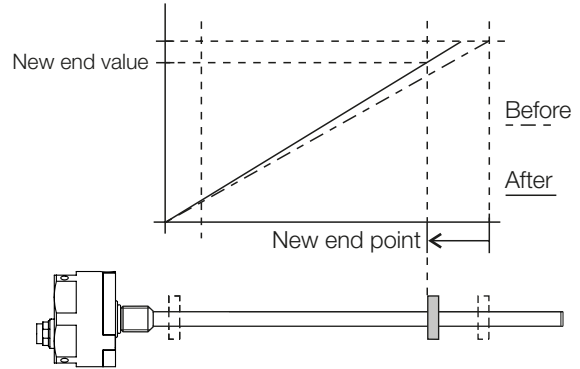

Fig. 6-5: Adjust a new end value

6.3.3 Reset

Restoring the transducer to its factory settings.

i The detailed procedure for the reset is described on page 19.

7

Teach-in

NOTICE!

Interference in function

Teach-in while the system is running may result in malfunctions.

- ▶ Stop the system before performing teach-in.

Displayed values (example)

At 0...10 V At 4...20 mA

Initial situation:

- Transducer with magnet within measuring range



5.39 V 9.15 mA

Activate teach-in

- ▶ Activate **(a)** for at least 4 s.
 - ⇒ Indication for teach-in is displayed.
 - ⇒ The current position value is displayed again once the button is released.

> 4 s **(a)**

4.00 V 12.00 mA

5.39 V 9.15 mA

Set null point

- ▶ Bring magnet to the new null point.
- ▶ Activate **(a)** for at least 2 s.
 - ⇒ The new null point is set.

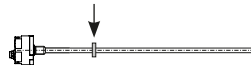

> 2 s **(a)**

1.04 V 4.82 mA

0.00 V 4.00 mA

Set end point

- ▶ Bring magnet to the new end point.
- ▶ Activate **(b)** for at least 2 s.
 - ⇒ The new end point is set.



> 2 s **(b)**

9.89 V 19.13 mA

10.00 V 20.00 mA

Inverting the characteristic curve (only with BTL7-C/E)

- ▶ Simultaneously activate **(a)** and **(b)** for at least 4 s.
 - ⇒ Error value is displayed.
 - ⇒ The characteristic curve of the output is inverted once released.

> 4 s **(a)+(b)**

3.60 mA

14.85 mA

End teach-in

- ▶ Briefly activate **(a)** and **(b)** simultaneously (< 1 s).
 - ⇒ The output indicates the error value during activation.
 - ⇒ Current position value is displayed.

< 1 s **(a)+(b)**

10.50 V 3.60 mA

10.00 V 4.00 mA

i Any of the individual steps for settings can be selected. The teach-in process can be ended at any time.

Programming line La = **(a)**
 Programming line Lb = **(b)**

8

Adjusting

NOTICE!

Interference in function

Adjustment while the system is running may result in malfunctions.

- ▶ Stop the system before performing adjustment.

Displayed values (example)

At 0...10 V At 4...20 mA

Initial situation:

- Transducer with magnet within measuring range



5.39 V

9.15 mA

Activate adjusting

- ▶ Activate (b) for at least 4 s.
 - ⇒ Indication for adjustment is displayed.
 - ⇒ The current position value is displayed again once the button is released.

> 4 s (b)

2.00 V

6.00 mA

5.39 V

9.15 mA

Set start point

- ▶ Bring magnet to the new start point.
- ▶ Activate (a) for at least 2 s.
 - ⇒ The new start point is set with the last valid start value.

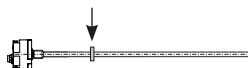

> 2 s (a)

1.04 V

4.82 mA

0.00 V

4.00 mA

Adjust start value

- ▶ The start value can be changed using (a) and (b). The gradient of the curve changes (see page 15).

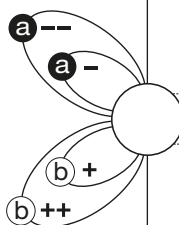

0.00 V

4.00 mA

0.90 V

7.20 mA

- ▶ End calibration procedure: Briefly activate (a) and (b) simultaneously (< 1 s).
 - ⇒ Set position value is saved.

< 1 s (a) + (b)

2.00 V

6.00 mA

0.90 V

7.20 mA

For setting the end point, adjusting the end value, and ending adjustment, see page 18.

i Any of the individual steps for settings can be selected. The adjustment process can be ended at any time.

8

Adjusting (continued)

Displayed values (example)

At 0...10 V At 4...20 mA

Set end point

▶ Bring magnet to the new end point.

▶ Activate (b) for at least 2 s.

⇒ The new end point is set with the last valid end value.



9.89 V	19.13 mA
--------	----------

> 2 s

(b)

10.00 V	20.00 mA
---------	----------

Adjust end value

▶ The end value can be changed using (a) and (b).
 The gradient of the curve changes (see page 15).

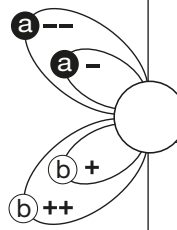

10.00 V	20.00 mA
---------	----------

8.00 V	16.80 mA
--------	----------

▶ End calibration procedure: Briefly press (a) and (b) simultaneously (< 1 s).

⇒ Set position value is saved.

< 1 s

(a+) (b)

2.00 V	6.00 mA
--------	---------

8.00 V	16.80 mA
--------	----------

End adjustment

▶ Briefly activate (a) and (b) simultaneously (< 1 s).

⇒ The current position value is displayed once the buttons are released.

< 1 s

(a+) (b)

10.50 V	3.60 mA
---------	---------

7.63 V	18.56 mA
--------	----------



Any of the individual steps for settings can be selected. The adjustment process can be ended at any time.

9

Resetting all values (reset)

NOTICE!

Interference in function

Resetting the values while the system is running may result in malfunctions.

- ▶ Stop the system before performing the reset.

The reset function can be used to restore all the settings to the factory settings. For a reset the magnet may also be located outside the measuring range.

Displayed values (example)

At 0...10 V At 4...20 mA

5.39 V	9.15 mA
--------	---------

10.50 V	3.60 mA
---------	---------

Activate reset

- ▶ Simultaneously activate **a** and **b** for at least 4 s. > 4 s **a + b**

Reset

- ▶ Simultaneously activate **a** and **b** for at least 4 s. > 4 s **a + b**

After activation:

- ⇒ All values are reset.
- ⇒ Current position value is displayed.
- ⇒ Reset is deactivated.

0.00 V	4.00 mA
--------	---------

9.89 V	19.13 mA
--------	----------

Abort reset

i Resetting can be aborted without any changes being saved after the *Activate reset* step.

- ▶ Briefly activate **a** and **b** simultaneously (< 1 s). < 1 s **a + b**

- ⇒ Current position value is displayed.

10 Technical data

10.1 Accuracy

The specifications are typical values for the BTL7-A/C/E/G... at 24 V DC and room temperature, with a nominal length of 500 mm in conjunction with the BTL-P-1013-4R, BTL-P-1013-4S, BTL-P-1012-4R or BTL-P-1014-2R magnet.

The transducer is ready immediately, full accuracy after warm-up phase.

i For special versions, other technical data may apply.
 Special versions are indicated by the suffix -SA on the part label.

Repeat accuracy	
Typical	±10 µm
Sampling rate	
Dependent on the nominal length	250 µs...5.5 ms
At nominal length = 500 mm	500 µs
Non-linearity at	
Nominal length ≤ 500 mm	±50 µm
Nominal length > 500 to ≤ 5500 mm	±0.01% FS
Nominal length > 5500 mm	±0.02% FS
Temperature coefficient ¹⁾	≤ 30 ppm/K
Max. detectable velocity	10 m/s

10.2 Ambient conditions²⁾

Operating temperature	-40°C...+85°C
Operating temperature for UL (only BTL7-...-KA...)	Max. +80°C
Storage temperature	-40°C...+100°C
Relative humidity	< 90%, non-condensing

Rod pressure rating (when installed in hydraulic cylinders)	
For Ø 8 mm	≤ 250 bar
For Ø 10.2 mm	≤ 600 bar
Shock rating	150 g/6 ms
Continuous shock per EN 60068-2-27 ³⁾	150 g/2 ms
Vibration per EN 60068-2-6 ³⁾ (note resonant frequency of the rod)	20 g, 10...2000 Hz
Degree of protection per IEC 60529	
Connector S32/S115 (when attached)	IP67
Cable	IP68 ³⁾

10.3 Supply voltage (external)

Voltage, stabilized⁴⁾:

BTL7-_5_ _-...	10...30 V DC
Ripple	≤ 0.5 V _{ss}
Current draw (at 24 V DC)	< 120 mA
Inrush current	≤ 500 mA/10 ms
Reverse polarity protection ⁵⁾	Up to 36 V
Overvoltage protection	Up to 36 V
Dielectric strength (GND to housing)	500 V AC

10.4 Output

BTL7-A... Output voltage	0...10 V and 10...0 V
Load current	≤ 5 mA
BTL7-C... Output current	0...20 mA/20...0 mA
Load resistance	≤ 500 ohms
BTL7-E... Output current	4...20 mA/20...4 mA
Load resistance	≤ 500 ohms
BTL7-G... Output voltage	-10...10 V and 10...-10 V
Load current	≤ 5 mA
Short circuit resistance	Signal cable to 36 V Signal cable to GND

10.5 Input

Programming inputs La, Lb:	High-active
BTL7-_5_ _-...	10...30 V DC
Overvoltage protection	up to 36 V

¹⁾ Nominal length 500 mm, magnet in the middle of the measuring range

²⁾ For : Use in enclosed spaces and up to a height of 2000 m above sea level.

³⁾ Individual specifications as per Balluff factory standard, resonances excluded

⁴⁾ For : The transducer must be externally connected via a limited-energy circuit as defined in UL 61010-1, a low-power source as defined in UL 60950-1, or a class 2 power supply as defined in UL 1310 or UL 1585.

⁵⁾ A prerequisite is that no current can flow between GND and 0 V in the event of polarity reversal.

10 Technical data (continued)

10.6 Dimensions, weights

Rod diameter	8 mm or 10.2 mm
Nominal length	
For Ø 8 mm	25...1016 mm
For Ø 10.2 mm	25...7620 mm
Weight (depends on length)	Approx. 2 kg/m
Housing material	Stainless steel
Flange material	Stainless steel
Rod material	Stainless steel
Rod wall thickness	
For Ø 8 mm	0.9 mm
For Ø 10.2 mm	2 mm
Young's modulus	Approx. 200 kN/mm ²
Housing mounting via threads	M18×1.5 or 3/4"-16UNF

BTL7-...-K__ ; BTL7-...-KA__

Cable material	PUR; cULus 20549 80°C, 300 V, internal wiring
Cable temperature	-40°C...+90°C
Cable diameter	Max. 7 mm
Permissible bending radius	
Fixed routing	≥ 35 mm
Movable	≥ 105 mm

BTL7-...-F__ ; BTL7-...-FA__

Cable material	PTFE No UL approval available
Cable temperature	-55°C...+200°C
Cable diameter	Max. 7 mm
Permissible bending radius	
Fixed routing	≥ 35 mm
Movable	No permissible bending radius

11 Accessories

Accessories are not included in the scope of delivery and must be ordered separately.

11.1 Magnets

BTL-P-1013-4R

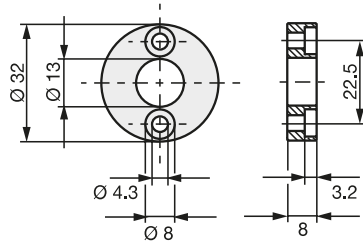

BTL-P-1013-4S

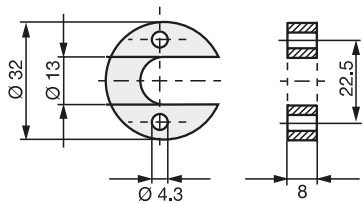

BTL-P-1012-4R

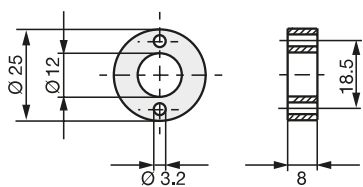

BTL-P-1014-2R

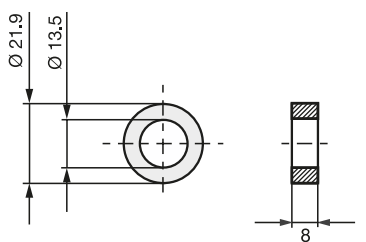

Fig. 11-1: Magnet installation dimensions

BTL-P-1013-4R, BTL-P-1013-4S, BTL-P-1012-4R, BTL-P-1014-2R:

Weight: Approx. 10 g
 Housing: Aluminum

Included in the scope of delivery for the BTL-P-1013-4R, BTL-P-1013-4S, BTL-P-1012-4R:

Spacer: 8 mm, material: polyoxymethylene (POM)

BTL5-P-4500-1 magnet (solenoid):

Weight: Approx. 90 g
 Housing: Plastic
 Operating temperature: $-40^{\circ}\text{C} \dots +60^{\circ}\text{C}$

BTL-P-1028-15R (special accessories for applications with a supporting rod):

Weight: Approx. 68 g
 Housing: Aluminum

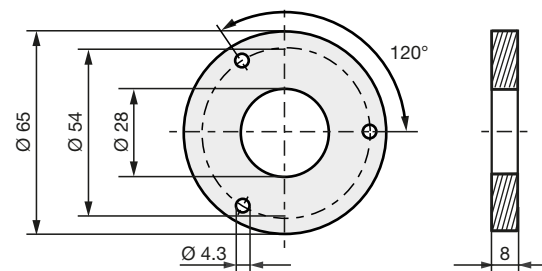

Fig. 11-2: BTL-P-1028-15R special accessories

11.2 Mounting nut

- M18x1.5 mounting nut:
BTL-A-FK01-E-M18x1.5
- 3/4"-16UNF mounting nut:
BTL-A-FK01-E-3/4"-16UNF

11 Accessories (continued)

11.3 Connectors and cables

11.3.1 BKS-S32/S33M-00, freely configurable

BKS-S32M-00

Straight connector, freely configurable
 M16 per IEC 130-9, 8-pin

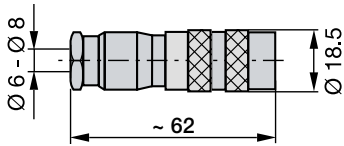

Fig. 11-3: Connector BKS-S32M-00

BKS-S33M-00

Angled connector, freely configurable
 M16 per IEC 130-9, 8-pin

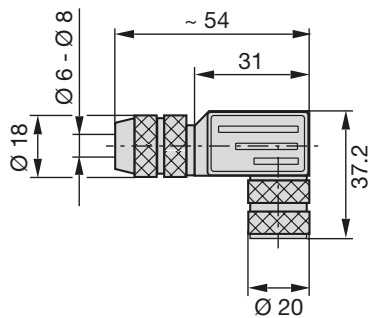

Fig. 11-4: Connector BKS-S33M-00

11.3.2 BKS-S232/S233-PU-__, preassembled

BKS-S232-PU-__

Straight connector, molded, preassembled
 M16, 8-pin
 Various cable lengths can be ordered, e.g.
 BKS-S232-PU-05: Cable length 5 m

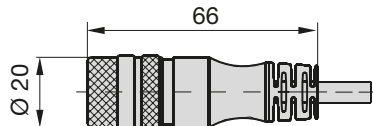

Fig. 11-5: Connector BKS-S232-PU-__

BKS-S233-PU-__

Angled connector, molded, preassembled
 M16, 8-pin
 Various cable lengths can be ordered, e.g.
 BKS-S233-PU-05: Cable length 5 m

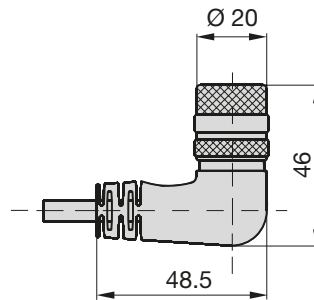

Fig. 11-6: Connector BKS-S233-PU-__

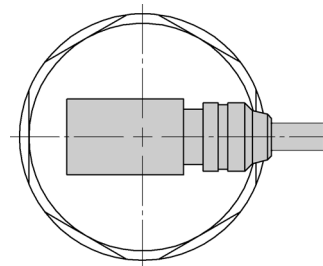

Fig. 11-7: Connector BKS-S233-PU-__, axial outlet

Pin	Color
1	YE yellow
2	GY gray
3	PK pink
4	RD red
5	GN green
6	BU blue
7	BN brown
8	WH white

Tab. 11-1: BKS-S232/S233-PU-__ pin assignment

1 1

Accessories (continued)

11.3.3 BKS-S115/S116-PU- __ , preassembled

BKS-S115-PU- __

Straight connector, molded-on cable, preassembled
 M12, 8-pin
 Various cable lengths can be ordered, e.g.
 BKS-S115-PU-05: Cable length 5 m

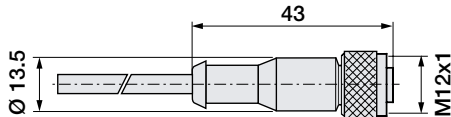

Fig. 11-8: Connector type BKS-S115-PU- __

BKS-S116-PU- __

Angled connector, molded-on cable, preassembled
 M12, 8-pin
 Various cable lengths can be ordered, e.g.
 BKS-S116-PU-05: Cable length 5 m

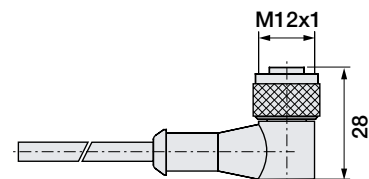

Fig. 11-9: Connector BKS-S116-PU- __

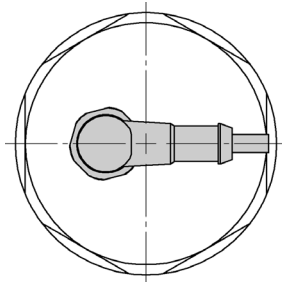

Fig. 11-10: Connector BKS-S116-PU- __, axial outlet

Pin	Color
1	YE yellow
2	GY gray
3	PK pink
4	RD red
5	GN green
6	BU blue
7	BN brown
8	WH white

Tab. 11-2: BKS-S115/116-PU- __ pin assignment

11.4 Calibration box

BTL7-A-CB02-S32

Scope of delivery:

- Calibration box
- 2 adapter cables, each approx. 0.3 m
- Condensed guide

BTL7-A-CB02-S115

Scope of delivery:

- Calibration box
- 2 adapter cables, each approx. 0.3 m
- Condensed guide

BTL7-A-CB02-K

Scope of delivery:

- Calibration box
- 2 adapter cables, each approx. 0.3 m/0.6 m
- Condensed guide

BTL7-A/C/E/G5__-M____-H/W(8)-S32/S115/____
Micropulse Transducer - Rod Style

12

Type code breakdown

BTL7 - E 5 0 0 - M0500 - H - S32

Micropulse transducer

Interface:

A = Analog interface, voltage output 0...10 V

G = Analog interface, voltage output -10...10 V

C = Analog interface, current output 0...20 mA

E = Analog interface, current output 4...20 mA

Supply voltage:

5 = 10...30 V DC

Output gradient:

00 = Rising (e.g. C_00 = 0...20 mA); only with BTL7-C/E

10 = Rising + falling (e.g. A_10 = 10...0 V and 0...10 V); only with BTL7-A/G

70 = Falling (e.g. C_70 = 20...0 mA); only with BTL7-C/E

Nominal length (4-digit):

M0500 = Metric specification in mm, nominal length 500 mm (M0025...M7620)

Rod version, fastening:

H = Metric mounting thread M18x1.5, O-ring, rod diameter 10.2 mm

W = 3/4"-16UNF thread, O-ring, rod diameter 10.2 mm

H8 = Metric mounting thread M18x1.5, O-ring, rod diameter 8 mm

W8 = 3/4"-16UNF thread, O-ring, rod diameter 8 mm

Electrical connection:

S32 = 8-pin, M16 plug per IEC 130-9, axial

S115 = 8-pin, M12 plug, axial

KA05 = Cable, 5 m, axial (PUR)

K05 = Cable, 5 m, radial (PUR)

FA05 = Cable, 5 m, axial (PTFE)

F05 = Cable, 5 m, radial (PTFE)

13 Appendix Section

13.1 Converting units of length

1 mm = 0.0393700787 inches

mm	inch
1	0.03937008
2	0.07874016
3	0.11811024
4	0.15748031
5	0.19685039
6	0.23622047
7	0.27559055
8	0.31496063
9	0.35433071
10	0.393700787

Tab. 13-1: Conversion table mm to inches

1 inch = 25.4 mm

inch	mm
1	25.4
2	50.8
3	76.2
4	101.6
5	127
6	152.4
7	177.8
8	203.2
9	228.6
10	254

Tab. 13-2: Conversion table inches to mm

13.2 Part label

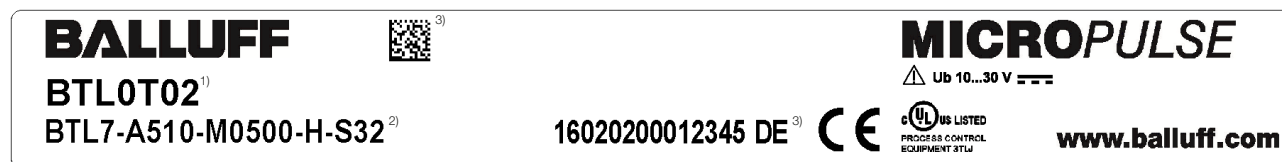

¹⁾ Ordering code

²⁾ Type

³⁾ Serial number

Fig. 13-1: BTL7 part label

**www.balluff.com**

Headquarters

Germany

Balluff GmbH
Schurwaldstrasse 9
73765 Neuhausen a.d.F.
Phone + 49 7158 173-0
Fax +49 7158 5010
balluff@balluff.de

Global Service Center

Germany

Balluff GmbH
Schurwaldstrasse 9
73765 Neuhausen a.d.F.
Phone +49 7158 173-370
Fax +49 7158 173-691
service@balluff.de

US Service Center

USA

Balluff Inc.
8125 Holton Drive
Florence, KY 41042
Phone (859) 727-2200
Toll-free 1-800-543-8390
Fax (859) 727-4823
technicalsupport@balluff.com

CN Service Center

China

Balluff (Shanghai) trading Co., Ltd.
Room 1006, Pujian Rd. 145.
Shanghai, 200127, P.R. China
Phone +86 (21) 5089 9970
Fax +86 (21) 5089 9975
service@balluff.com.cn