

BTL7-V50T-M_____P-C003

User's Guide

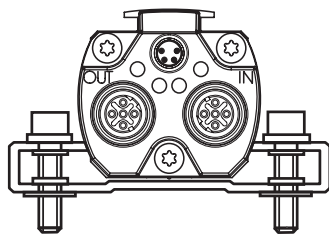

www.balluff.com

1	Notes to the user	4
1.1	Validity	4
1.2	Symbols and conventions	4
1.3	Scope of delivery	4
1.4	Approvals and markings	4
2	Safety	5
2.1	Intended use	5
2.2	General safety notes for the position measuring system	5
2.3	Explanation of the warnings	5
2.4	Disposal	5
3	Construction and function	6
3.1	Construction	6
3.2	Function	6
3.3	LED display	7
3.3.1	LED 1: BTL status	7
3.3.2	LED 2: PROFINET status (dual LED)	7
3.3.3	LED 3/LED 4: Link/Activity	7
4	Installation and connection	8
4.1	Installing the transducer	8
4.2	Captive magnets	8
4.3	Floating magnets	9
4.4	Electrical connection	10
4.4.1	Connector BTL7-...-C003	10
4.5	Shielding and cable routing	10
5	Startup	11
5.1	Starting up the system	11
5.2	Operating notes	11
6	Technical data	12
6.1	Accuracy	12
6.2	Ambient conditions	12
6.3	Supply voltage (external)	12
6.4	Output	12
6.5	Dimensions, weights	12
6.6	Maximum sampling rate f_{\max}	12
7	Accessories	13
7.1	Captive magnets	13
7.2	BTL2-GS10-____-A joint rod	13
7.3	Floating magnets	14
7.4	Connector	15
7.4.1	Power cable, preassembled with straight M8 plug	15
7.4.2	Power cable, preassembled with angled M8 plug	15
7.4.3	Data cable, preassembled with M12 plug	15
7.4.4	Data cable, preassembled with RJ45 plug	15
7.4.5	Straight data plug, freely configurable	16
7.4.6	Angled data plug, freely configurable	16
8	Type code breakdown	17
9	Appendix	18
9.1	Converting units of length	18
9.2	Part label	18

BTL7-V50T-M____-P-C003 Micropulse Transducer in a Profile Housing

1

Notes to the user

1.1 Validity

This guide describes the construction, function and setup options for the BTL7 Micropulse Transducer with PROFINET interface. It applies to types **BTL7-V50T-M____-P-C003** (see Type code breakdown on page 17).

The guide is intended for qualified technical personnel. Read this guide before installing and operating the transducer.

1.2 Symbols and conventions

Individual **instructions** are indicated by a preceding triangle.

- ▶ Instruction 1

Action sequences are numbered consecutively:

1. Instruction 1
2. Instruction 2



Note, tip

This symbol indicates general notes.

1.3 Scope of delivery

- BTL7 transducer
- Mounting clamps with insulating sleeves and screws
- Condensed guide



The magnets are available in various models and must be ordered separately.

1.4 Approvals and markings



UL approval
File no.
E227256



Certified in accordance with
Conformance Class A, B and C.



The CE Mark verifies that our products meet the requirements of EU Directive 2004/108/EC (EMC Directive).

The transducer meets the requirements of the following generic standards:

- EN 61000-6-1 (noise immunity)
- EN 61000-6-2 (noise immunity)
- EN 61000-6-3 (emission)
- EN 61000-6-4 (emission)

and the following product standard:

- EN 61326-2-3

Emission tests:

- RF emission
EN 55016-2-3 (industrial and residential areas)

Noise immunity tests:

- Static electricity (ESD)
EN 61000-4-2 Severity level 3
- Electromagnetic fields (RFI)
EN 61000-4-3 Severity level 3
- Electrical fast transients (burst)
EN 61000-4-4 Severity level 3
- Surge
EN 61000-4-5 Severity level 2
- Conducted interference induced
by high-frequency fields
EN 61000-4-6 Severity level 3
- Magnetic fields
EN 61000-4-8 Severity level 4



More detailed information on the guidelines, approvals, and standards is included in the declaration of conformity.

2

Safety

2.1 Intended use

The Micropulse Transducer, together with a machine controller (e.g. PLC), comprises a position measuring system. It is intended to be installed into a machine or system. Flawless function in accordance with the specifications in the technical data is ensured only when using original BALLUFF accessories. Use of any other components will void the warranty.

Opening the transducer or non-approved use are not permitted and will result in the loss of warranty and liability claims against the manufacturer.

2.2 General safety notes for the position measuring system

Installation and **startup** may only be performed by trained specialists with basic electrical knowledge.

Qualified personnel are those who can recognize possible hazards and institute the appropriate safety measures due to their professional training, knowledge, and experience as well as their understanding of the relevant regulations pertaining to the work to be done.

The **operator** is responsible for ensuring that local safety regulations are observed. In particular, the operator must take steps to ensure that a defect in the position measuring system will not result in hazards to persons or equipment. If defects and unresolvable faults occur in the transducer, it should be taken out of service and secured against unauthorized use.

2.3 Explanation of the warnings

Always observe the warnings in these instructions and the measures described to avoid hazards.

The warnings used here contain various signal words and are structured as follows:

SIGNAL WORD
Hazard type and source Consequences if not complied with ▶ Measures to avoid hazards

The individual signal words mean:

NOTICE! Identifies a hazard that could damage or destroy the product .
 DANGER The general warning symbol in conjunction with the signal word DANGER identifies a hazard which, if not avoided, will certainly result in death or serious injury .

2.4 Disposal

- ▶ Observe the national regulations for disposal.

BTL7-V50T-M____-P-C003 Micropulse Transducer in a Profile Housing

3

Construction and function

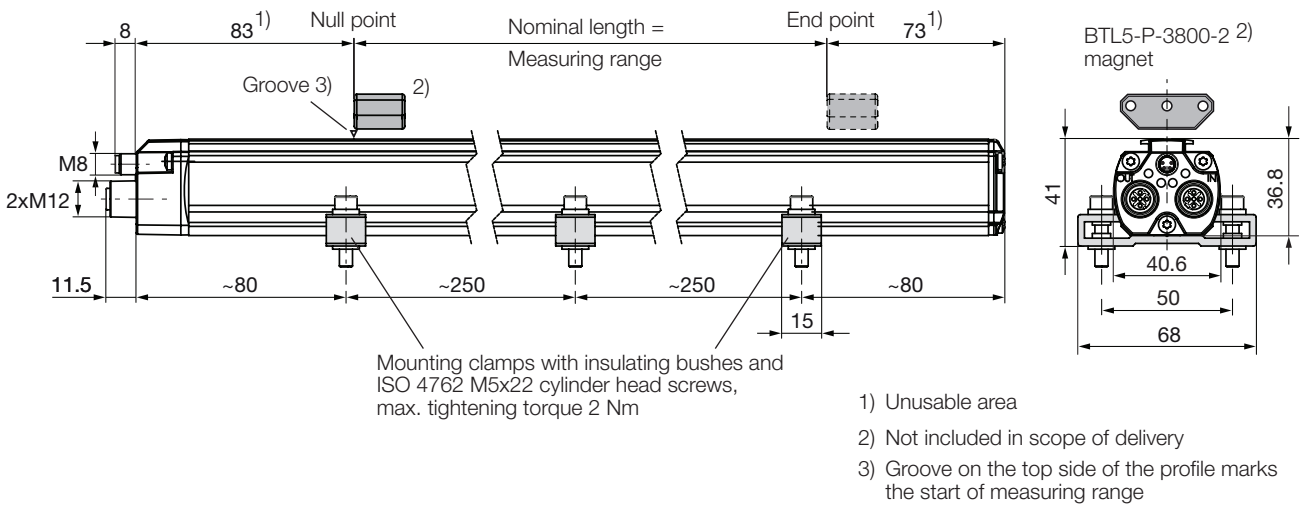

Fig. 3-1: BTL7... transducer, construction

3.1 Construction

Electrical connection: The electrical connection is made via a connector (see Type code breakdown on page 17).

BTL housing: Aluminum housing containing the waveguide and processing electronics.

Magnet: Defines the position to be measured on the waveguide. Magnets are available in various models and must be ordered separately (see Accessories on page 13).

Nominal length: To optimally adapt the transducer to the application, nominal lengths from 50 mm to 7620 mm are available.

3.2 Function

The BTL7 transducer contains the waveguide which is protected by an aluminum housing. A magnet is moved along the waveguide. This magnet is connected to the system part whose position is to be determined.

The magnet defines the position to be measured on the waveguide.

An internally generated INIT pulse interacts with the magnetic field of the magnet to generate a torsional wave in the waveguide which propagates at ultrasonic speed.

The component of the torsional wave which arrives at the end of the waveguide is absorbed in the damping zone to prevent reflection. The component of the torsional wave which arrives at the beginning of the waveguide is converted by a coil into an electrical signal. The travel time of the wave is used to calculate the position.

This information is transferred via the PROFINET interface. PROFINET is an industrial bus system based on the physical layer of the Ethernet (see www.profibus.com).

The transducer can detect and process up to 16 magnets. The maximum number of magnets depends on the nominal length. The position and velocity of each magnet can be output.

Implementation is based on the PNO encoder profile V4.1.

The following functions are also available:

- Number of magnets can be parameterized through the telegram selection. A fixed number from 1 to 16 or flexible (FMM). In FMM, the number of magnets corresponds to the number of magnets detected, with a maximum of 16
- Setting the resolution of the position and velocity output
- Reversal of the measuring direction
- Setting presets/offsets
- Temperature sensor. Read out current, minimum, and maximum temperature.

Synchronous operation with IRT is possible from a cycle time of 2 ms. The minimum possible cycle time is dependent on the length and configuration.

Supported PROFINET functions:

- RTC class 1 and 3
- RTA (Real Time Acyclic Protocol)
- DCP (Discover and Configuration Protocol)
- CL-RPC (Connectionless Remote Procedure Call)
- LLDP (Link Layer Discovery Protocol)
- SNMP (Simple Network Management Protocol)
- MRP (Media Redundancy Protocol) Client

BTL7-V50T-M____-P-C003 Micropulse Transducer in a Profile Housing



Construction and function (continued)

3.3 LED display

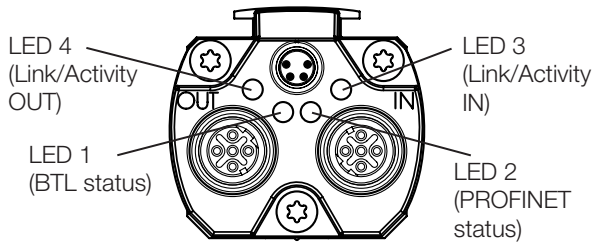

Fig. 3-2: BTL7 LED displays

3.3.1 LED 1: BTL status

LED 1	Operating state
Green	Normal function Magnet is within the limits.
Red	Error No magnet or magnet outside the limits.

Tab. 3-1: LED 1

3.3.2 LED 2: PROFINET status (dual LED)

LED 2			
Red (Bus Failure)	Green	Meaning	Cause
Off	Off	No supply voltage	
On	On	No bus connection with other participants (no link)	Bus not connected Master cannot be accessed or is switched off
Flashing ¹⁾	On	Bus connection (link) available, but the sensor is not involved in cyclic data exchange.	Sensor is starting up, but parameterization has not yet been completed. Sensor has been incorrectly configured. The sensor was assigned an incorrect station address and is thus not accessible. The desired configuration is not the same as the sensor configuration.
Off	On	The sensor is involved in cyclic data exchange.	

¹⁾ Flashing frequency is 0.5 Hz. The signal is shown for at least 3 s.

Tab. 3-2: LED 2

3.3.3 LED 3/LED 4: Link/Activity

LED 3/LED 4 Green	Status	Connection
On	Port open	Yes
Flashing	Requested by the master to identify the device	Yes
Off	Port closed	No

Tab. 3-3: LED 3/4

4

Installation and connection

4.1 Installing the transducer

NOTICE!

Improper installation
 Improper installation can compromise the function of the transducer and result in damage.

- ▶ For this reason, ensure that no strong electrical or magnetic fields are present in the immediate vicinity of the transducer.
- ▶ The recommended spacing for the installation must be strictly observed.

Any orientation is permitted. Mount the transducer on a level surface of the machine using the provided mounting clamps and cylinder-head screws. A sufficient number of mounting clamps is supplied.

i In order to avoid the development of resonant frequencies from vibration loads, we recommend arranging the mounting clamps at irregular intervals.

The transducer is electrically isolated from the machine with the supplied insulating bushes (see Figure 3-1).

1. Guide the transducer into the mounting clamps.
2. Attach transducer to the base using mounting screws (tighten screws in the clamps with max. 2 Nm).
3. Insert magnet (accessories).

i The micropulse transducer in profile housing is suitable both for floating, i.e. non-contacting magnets (see Figures 4-5 to 4-9) and for captive magnets (see Figures 4-2 to 4-4).

The distance (L) between the magnets must be at least 65 mm.

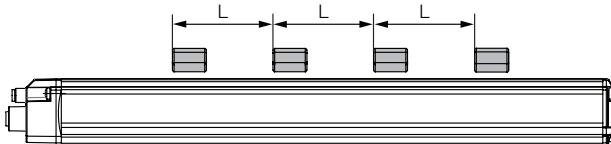

Fig. 4-1: Distance between the magnets

4.2 Captive magnets

The following must be observed when installing the magnet:

- Avoid lateral forces.
- Connect the magnet to the machine member with a joint rod (see Accessories on page 13).

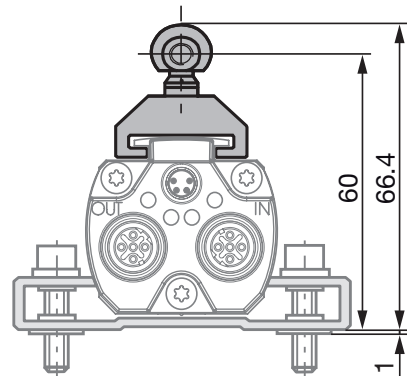

Fig. 4-2: Dimensions and distances with BTL5-F-2814-1S magnet

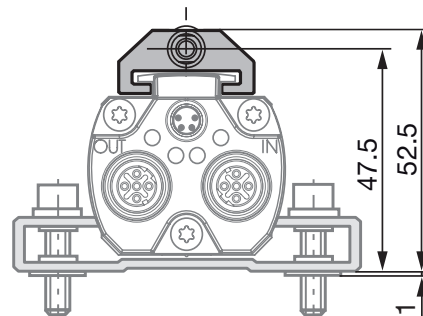

Fig. 4-3: Dimensions and distances with BTL5-T-2814-1S magnet

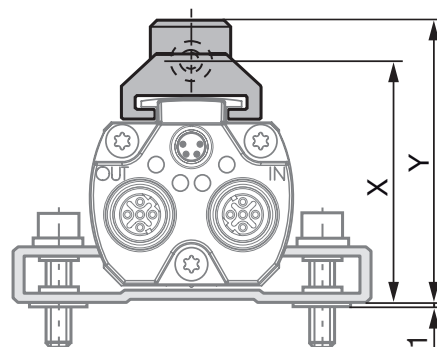

Fig. 4-4: Dimensions and distances with BTL5-M/N-2814-1S magnet

	BTL5-M-2814-1S	BTL5-N-2814-1S
Distance X	48.5 mm	57 mm
Distance Y	51 mm	59.5 mm

Tab. 4-1: Distances with BTL5-M/N-2814-1S magnet

4

Installation and connection (continued)

4.3 Floating magnets

The following must be observed when installing the magnet:

- To ensure the accuracy of the position measuring system, the magnet is attached to the moving member of the machine using non-magnetizable screws (stainless steel, brass, aluminum).
- The moving member must guide the magnet on a track parallel to the transducer.
- Ensure that the distance A between parts made of magnetizable material and the magnet is at least 10 mm (see Figures 4-5 to 4-9).
- Maintain the following values for distance B between the magnet and transducer and for center offset C (see Figures 4-5 to 4-9):

Type of magnet	Distance B ¹⁾	Offset C
BTL5-P-3800-2	0.1 to 4 mm	± 2 mm
BTL5-P-5500-2	5 to 15 mm	± 15 mm
BTL5-P-4500-1	0.1 to 2 mm	± 2 mm
BTL6-A-3800-2	4 to 8 mm ²⁾	± 2 mm
BTL6-A-3801-2	4 to 8 mm ²⁾	± 2 mm

¹⁾ The selected distance should stay constant over the entire measuring length.

²⁾ For optimum measurement results, a distance B of 6 to 8 mm is recommended.

Tab. 4-2: Distance and offset for floating magnets

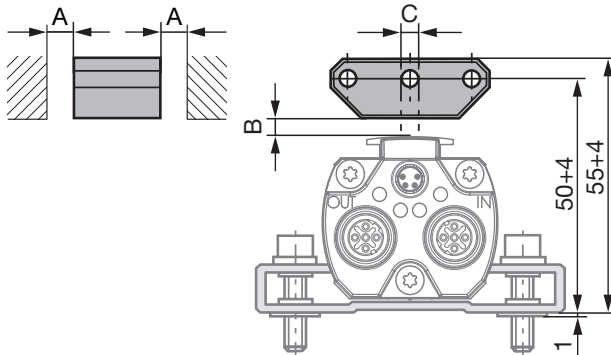

Fig. 4-5: Dimensions and distances with BTL5-P-3800-2 magnet

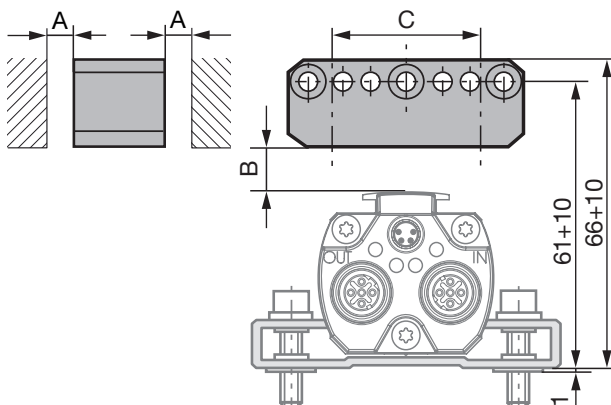

Fig. 4-6: Dimensions and distances with BTL5-P-5500-2 magnet

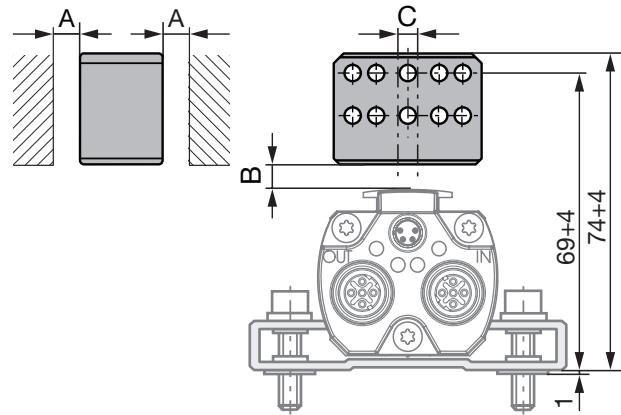

Fig. 4-7: Dimensions and distances with BTL6-A-3800-2 magnet

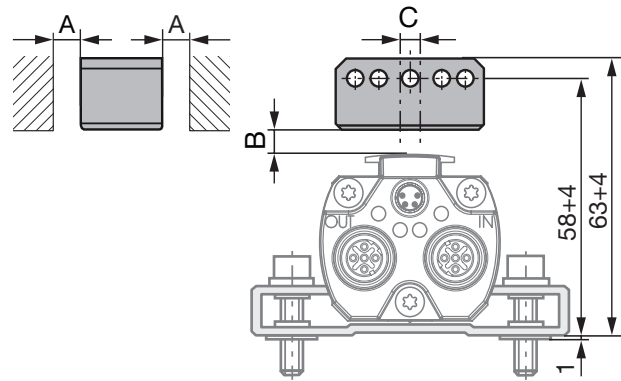

Fig. 4-8: Dimensions and distances with BTL6-A-3801-2 magnet

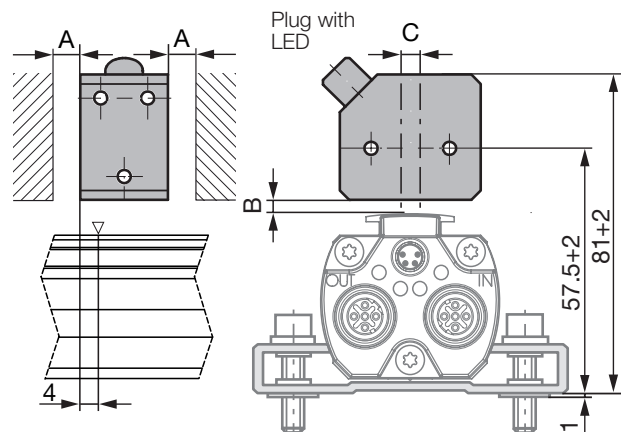

Fig. 4-9: Dimensions and distances with BTL5-P-4500-1 electromagnet (24 V/100 mA)



The measuring range is offset by 4 mm towards the BTL plug (see Figure 4-9).

4

Installation and connection (continued)

4.4 Electrical connection

The transducer is connected via a connector.
 The pin assignments for the respective version can be found in Table 4-3.

i Note the information on shielding and cable routing.

4.4.1 Connector BTL7-...-C003

Power		
Pin	Cable color	Signal
1	BN brown	10 to 30 V DC
2	WH white	Not used ¹⁾
3	BU blue	0 V GND ²⁾
4	BK black	Not used ¹⁾

BUS IN/OUT (data)		
Pin	Cable color	Signal
1	YE yellow	TX+
2	WH white	RX+
3	OG orange	TX-
4	BU blue	RX-

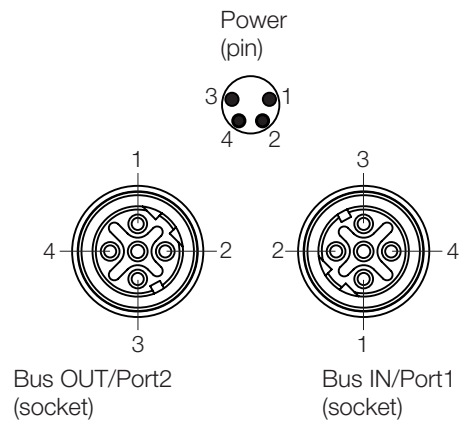

Fig. 4-10: Pin assignment of connector (view from above on transducer)

¹⁾ Unassigned leads can be connected to the GND on the controller side but not to the shield.

²⁾ Reference potential for supply voltage and EMC-GND.

Tab. 4-3: Pin assignment of ...-C003 connector

4.5 Shielding and cable routing

i **Defined ground!**
 The transducer and the control cabinet must be at the same ground potential.

Shielding

To ensure electromagnetic compatibility (EMC), observe the following:

- Connect transducer and controller using a shielded cable. Shielding: Braided copper shield with minimum 85% coverage.
- Connector version: Shield is internally connected to connector housing.

Magnetic fields

The position measuring system is a magnetostrictive system. It is important to maintain adequate distance between the transducer and strong, external magnetic fields.

Cable routing

Do not route the cable between the transducer, controller, and power supply near high voltage cables (inductive stray noise is possible).

The cable must be routed tension-free.

Cable length

The maximum cable length when using CAT5e cables is 100 m¹⁾.

¹⁾ Prerequisite: Construction, shielding and routing preclude the effect of any external noise fields.

Noise elimination

To avoid equipotential bonding - a current flow - through the cable shield, please note the following:

- Use insulating bushes
- Put the control cabinet and the system in which the BTL7 is located to the same ground potential.

5

Startup

5.1 Starting up the system

DANGER

Uncontrolled system movement

When starting up, if the position measuring system is part of a closed loop system whose parameters have not yet been set, the system may perform uncontrolled movements. This could result in personal injury and equipment damage.

- ▶ Persons must keep away from the system's hazardous zones.
- ▶ Startup must be performed only by trained technical personnel.
- ▶ Observe the safety instructions of the equipment or system manufacturer.

1. Check connections for tightness and correct polarity. Replace damaged connections.
2. Turn on the system.
3. Check measured values and adjustable parameters and readjust the transducer, if necessary.



Check for the correct values at the null point and end point, especially after replacing the transducer or after repair by the manufacturer.

5.2 Operating notes

- Check the function of the position measuring system and all associated components on a regular basis.
- Take the position measuring system out of operation whenever there is a malfunction.
- Secure the system against unauthorized use.

BTL7-V50T-M____-P-C003

Micropulse Transducer in a Profile Housing



Technical data

6.1 Accuracy

The specifications are typical values for BTL7-V50T... at 24 V DC and room temperature, with a nominal length of 500 mm in conjunction with the BTL5-P-3800-2, BTL5-P-4500-1, BTL5-P-5500-2¹⁾, BTL6-A-3800-2¹⁾, BTL6-A-3801-2¹⁾, BTL5-F-2814-1S, BTL5-T-2814-1S, BTL5-M-2814-1S or BTL5-N-2814-1S.

The BTL is fully operational immediately, with full accuracy after warm-up.



For special versions, other technical data may apply. Special versions are indicated by the suffix -SA on the part label.

Position resolution	1 μm
Non-linearity with a constant distance between the magnet and profile:	
Nominal length \leq 5500 mm	$\pm 30 \mu\text{m}$
Nominal length $>$ 5500 mm	$\pm 0.02 \%$ FS
Hysteresis	$\leq \pm 10 \mu\text{m}$
Repeat accuracy	$\leq \pm 5 \mu\text{m}$ (typ. $\pm 2.5 \mu\text{m}$)
Temperature coefficient ²⁾	$\leq 18 \text{ ppm/K}$
Velocity resolution	0.1 mm/s
Min. detectable velocity	1 mm/s
Max. detectable velocity	10 m/s

6.2 Ambient conditions³⁾

Operating temperature	-40°C to $+85^\circ\text{C}$
Storage temperature	-40°C to $+100^\circ\text{C}$
Relative humidity	$< 90\%$, non-condensing
Shock rating per EN 60068-2-27 ⁴⁾	150 g/6 ms
Continuous shock per EN 60068-2-29 ⁴⁾	150 g/2 ms
Vibration per EN 60068-2-6 ⁴⁾	20 g, 10 to 2000 Hz
Degree of protection per IEC 60529	
Connector C003 (when attached)	IP 67

6.3 Supply voltage (external)

Voltage, stabilized ⁵⁾	10 to 30 V DC
Ripple	$\leq 0.5 V_{\text{SS}}$
Current draw (at 24 V DC)	$\leq 120 \text{ mA}$ up to 1524 mm $\leq 160 \text{ mA}$ from 1525 mm
Inrush current	$\leq 500 \text{ mA}/10 \text{ ms}$
Reverse polarity protection	Up to 36 V
Overvoltage protection	Up to 36 V
Dielectric strength (GND to housing)	500 V AC

6.4 Output

Short-circuit resistance	Signal cable to GND
--------------------------	---------------------

6.5 Dimensions, weights

Housing height	36.8 mm
Nominal length	50 to 7620 mm
Weight (depends on length)	Approx. 1.4 kg/m
Housing material	Anodized aluminum

6.6 Maximum sampling rate f_{max}

At nominal length	
0050 to 0250 mm	780 Hz
0251 to 0600 mm	710 Hz
0601 to 1300 mm	600 Hz
1301 to 2700 mm	460 Hz
2701 to 5500 mm	245 Hz
5501 to 7600 mm	180 Hz
$> 7601 \text{ mm}$	170 Hz

¹⁾ In the position range 0 to 20 mm, the specified linearity limit can be exceeded by $\pm 100 \mu\text{m}$.

²⁾ Nominal length = 500 mm, magnet in the middle of the measuring range

³⁾ For : Use in enclosed spaces and up to a height of 2000 m above sea level.

⁴⁾ Individual specifications as per Balluff factory standard

⁵⁾ For : The transducer must be externally connected via a limited-energy circuit as defined in UL 61010-1, a low-power source as defined in UL 60950-1, or a class 2 power supply as defined in UL 1310 or UL 1585.

BTL7-V50T-M____-P-C003 Micropulse Transducer in a Profile Housing

7

Accessories

7.1 Captive magnets

BTL5-M/N-2814-1S

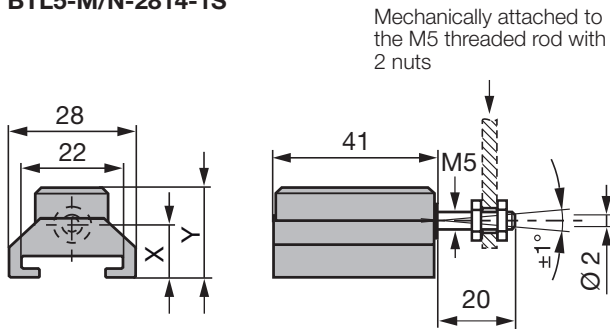

Fig. 7-1: Installation dimensions of BTL5-M/N-2814-1S magnet

	BTL5-M-2814-1S	BTL5-N-2814-1S
Distance X	12.5 mm	15 mm
Distance Y	21 mm	23.5 mm
Weight:	Approx. 32 g	Approx. 35 g
Housing:	Anodized aluminum	Anodized aluminum
Slide surface:	Plastic	Plastic

BTL5-F-2814-1S

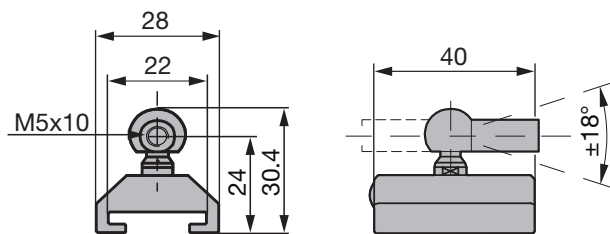

Fig. 7-2: Installation dimensions of BTL5-F-2814-1S magnet

Weight:	Approx. 28 g
Housing:	Anodized aluminum
Slide surface:	Plastic

BTL5-T-2814-1S

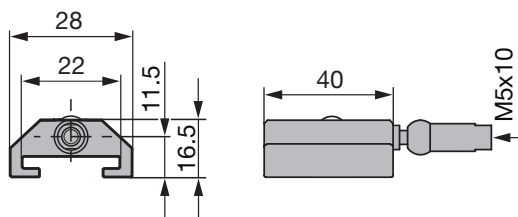

Fig. 7-3: Installation dimensions of BTL5-T-2814-1S magnet

Weight:	Approx. 28 g
Housing:	Anodized aluminum
Slide surface:	Plastic

7.2 BTL2-GS10-____-A joint rod

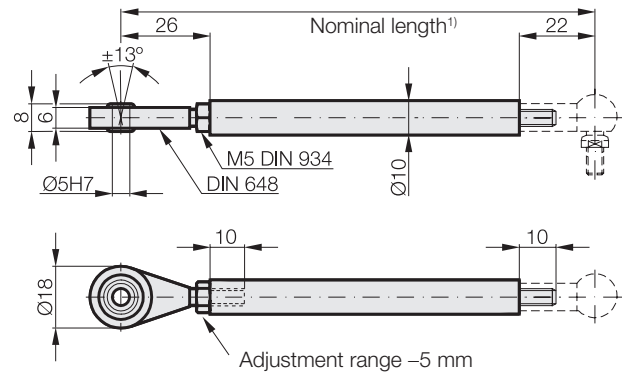

Fig. 7-4: BTL2-GS10-____-A joint rod

Weight:	Approx. 150 g/m
Material:	Aluminum

¹) State the nominal length when ordering

Example: BTL2-GS10-**0100**-A (nominal length = 100 mm)

7

Accessories (continued)

7.3 Floating magnets

BTL5-P-3800-2

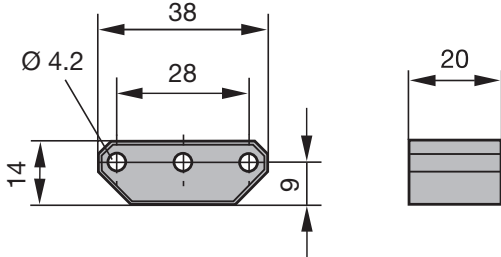

Fig. 7-5: Installation dimensions of BTL5-P-3800-2 magnet

Weight: Approx. 12 g
 Housing: Plastic

BTL5-P-5500-2

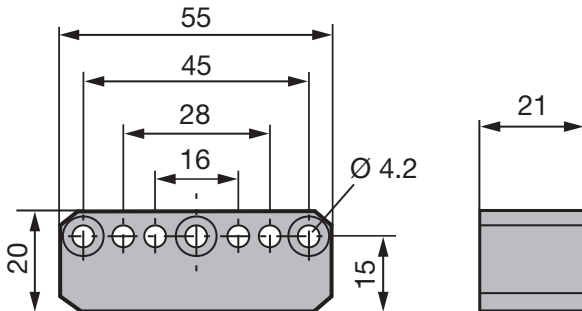

Fig. 7-6: Installation dimensions of BTL5-P-5500-2 magnet

Weight: Approx. 40 g
 Housing: Plastic

BTL6-A-3800-2

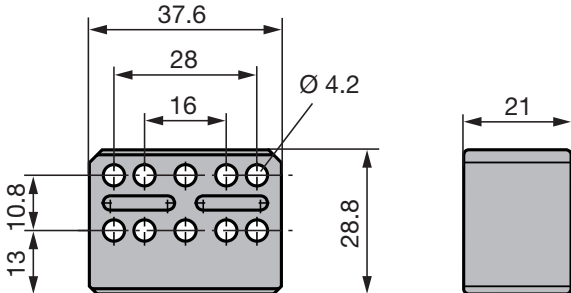

Fig. 7-7: Installation dimensions of BTL6-A-3800-2 magnet

Weight: Approx. 30 g
 Housing: Plastic

BTL6-A-3801-2

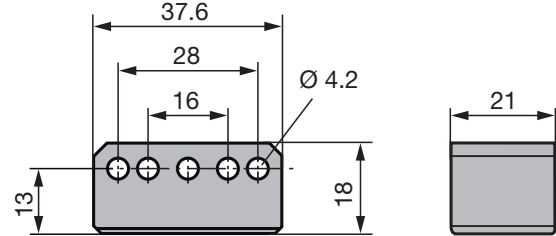

Fig. 7-8: Installation dimensions of BTL6-A-3801-2 magnet

Weight: Approx. 25 g
 Housing: Plastic

BTL5-P-4500-1

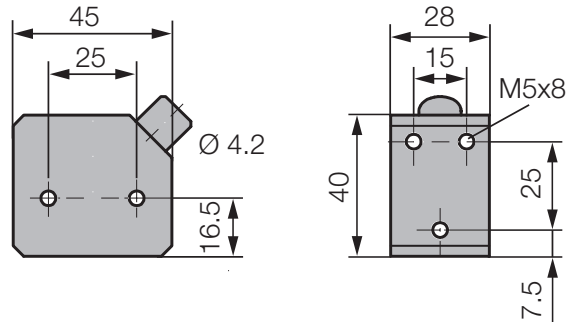

Fig. 7-9: Installation dimensions of BTL5-P-4500-1 magnet

Weight: Approx. 90 g
 Housing: Plastic
 Operating temperature: -40°C to +60°C

Special advantage of the BTL5-P-4500-1 magnet: Several magnets on the same transducer can be separately switched on and off electrically (actuation with a PLC signal).

BTL7-V50T-M____-P-C003 Micropulse Transducer in a Profile Housing

7

Accessories (continued)

7.4 Connector

7.4.1 Power cable, preassembled with straight M8 plug

- Straight or angled connector, molded, preassembled
- M8 socket, 4-pin

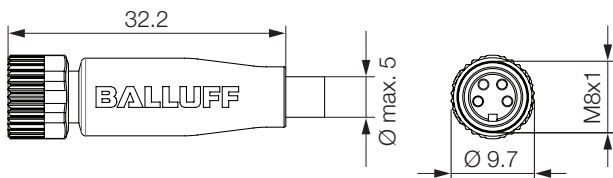

Fig. 7-10: Connector - straight socket

Type	Ordering code
BCC M314-0000-10-014-PS0434-020	BCC02N5
BCC M314-0000-10-014-PS0434-050	BCC02N6
BCC M314-0000-10-014-PS0434-100	BCC02N7

Examples:

BCC M314-0000-10-014-PS0434-**020** = cable length of 2 m

BCC M314-0000-10-014-PS0434-**050** = cable length of 5 m

7.4.2 Power cable, preassembled with angled M8 plug

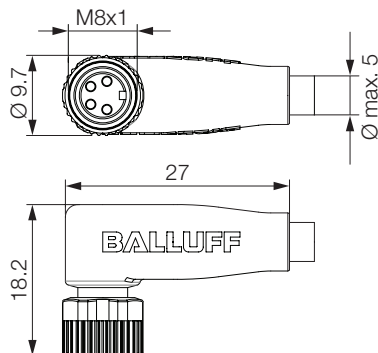

Fig. 7-11: Connector - angled socket

Type	Ordering code
BCC M324-0000-10-014-PS0434-020	BCC02NH
BCC M324-0000-10-014-PS0434-050	BCC02NJ
BCC M324-0000-10-014-PS0434-100	BCC02NK

Examples:

BCC M314-0000-10-014-PS0434-**020** = cable length of 2 m

BCC M314-0000-10-014-PS0434-**050** = cable length of 5 m

7.4.3 Data cable, preassembled with M12 plug

- Straight connector, molded, preassembled
- M12 plug (I), M12 plug (II), 4-pin

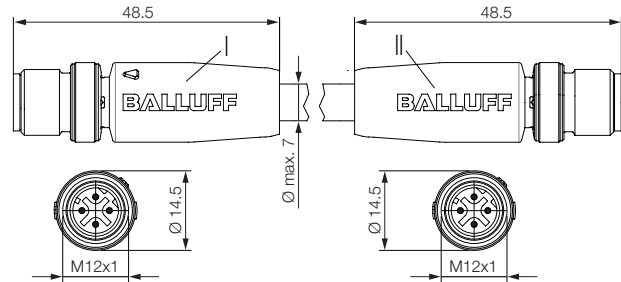

Fig. 7-12: Straight-straight connector

Type	Ordering code
BCC M414-M414-6D-331-PS54T2-020	BCC04K1
BCC M414-M414-6D-331-PS54T2-050	BCC04K2
BCC M414-M414-6D-331-PS54T2-100	BCC04K3
BCC M414-M414-6D-331-PS54T2-200	BCC04K4

Examples:

BCC M414-M414-6D-331-PS54T2-**020** = cable length of 2 m

BCC M414-M414-6D-331-PS54T2-**050** = cable length of 5 m

7.4.4 Data cable, preassembled with RJ45 plug

- Straight connector, molded, preassembled
- M12 plug (I), RJ45 plug (II), 4-pin

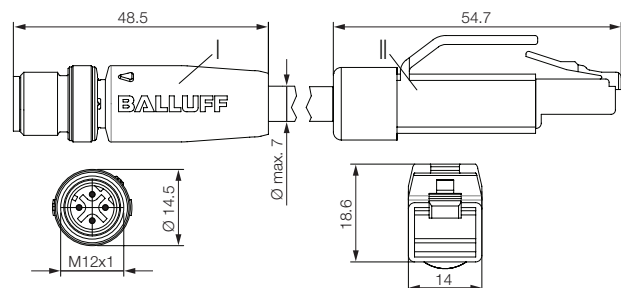

Fig. 7-13: Straight-straight connector

Type	Ordering code
BCC M414-E834-8G-668-PS54T2-020	BCC04K7
BCC M414-E834-8G-668-PS54T2-050	BCC04K8
BCC M414-E834-8G-668-PS54T2-100	BCC04K9
BCC M414-E834-8G-668-PS54T2-150	BCC04ZJ
BCC M414-E834-8G-668-PS54T2-200	BCC04KA

Examples:

BCC M414-E834-8G-668-PS54T2-**020** = cable length of 2 m

BCC M414-E834-8G-668-PS54T2-**050** = cable length of 5 m

7

Accessories (continued)

7.4.5 Straight data plug, freely configurable

- Straight or angled connector, freely configurable
- M12 plug, 4-pin

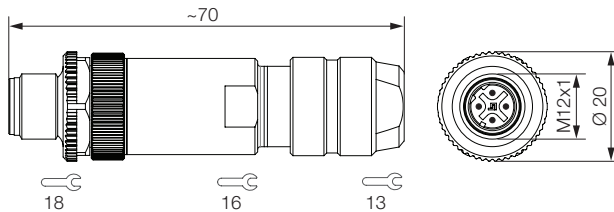

Fig. 7-14: Connector - straight plug

Type

BCC M474-0000-2D-000-51X475-000

Ordering code

BCC03WZ

7.4.6 Angled data plug, freely configurable

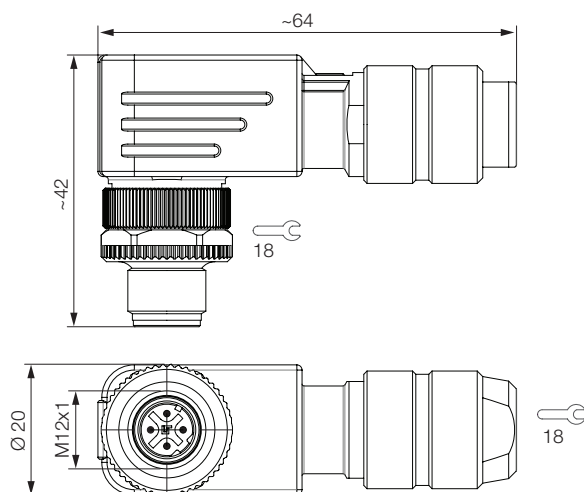

Fig. 7-15: Connector - angled plug

Type

BCC M484-0000-2D-000-51X475-000

Ordering code

BCC03Y0

BTL7-V50T-M____-P-C003

Micropulse Transducer in a Profile Housing

8

Type code breakdown

BTL7 - V 5 0 T - M0500 - P - C003

Micropulse transducer

Ethernet interface

Supply voltage:
5 = 10 to 30 V DC

Output gradient:
0 = Configurable

Ethernet interface type:
T = PROFINET

Nominal length (4-digit):
M0500 = Metric specification in mm, nominal length 500 mm (M0050 to M7620)

Construction:
P = profile housing

Electrical connection:
C003 = 4-pin, 1 x M8 plug + 2 x M12 plug, D-coded

BTL7-V50T-M____-P-C003

Micropulse Transducer in a Profile Housing

9

Appendix

9.1 Converting units of length

1 mm = 0.0393700787 inches

mm	inch
1	0.03937008
2	0.07874016
3	0.11811024
4	0.15748031
5	0.19685039
6	0.23622047
7	0.27559055
8	0.31496063
9	0.35433071
10	0.393700787

Tab. 9-1: Conversion table mm to inches

1 inch = 25.4 mm

inch	mm
1	25.4
2	50.8
3	76.2
4	101.6
5	127
6	152.4
7	177.8
8	203.2
9	228.6
10	254

Tab. 9-2: Conversion table inches to mm

9.2 Part label

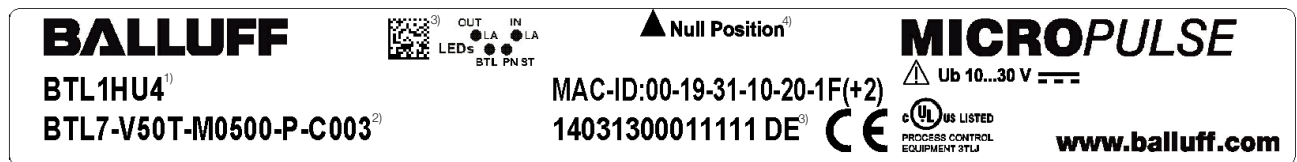

- ¹⁾ Ordering code
- ²⁾ Type
- ³⁾ Serial number
- ⁴⁾ Null mark

Fig. 9-1: BTL7 part label