

BTL7-S5 _ _ (B)-M _ _ _ -A/B/Y/Z(8)-S32/S115/S140/S147/ _ _ _ _

User's Guide

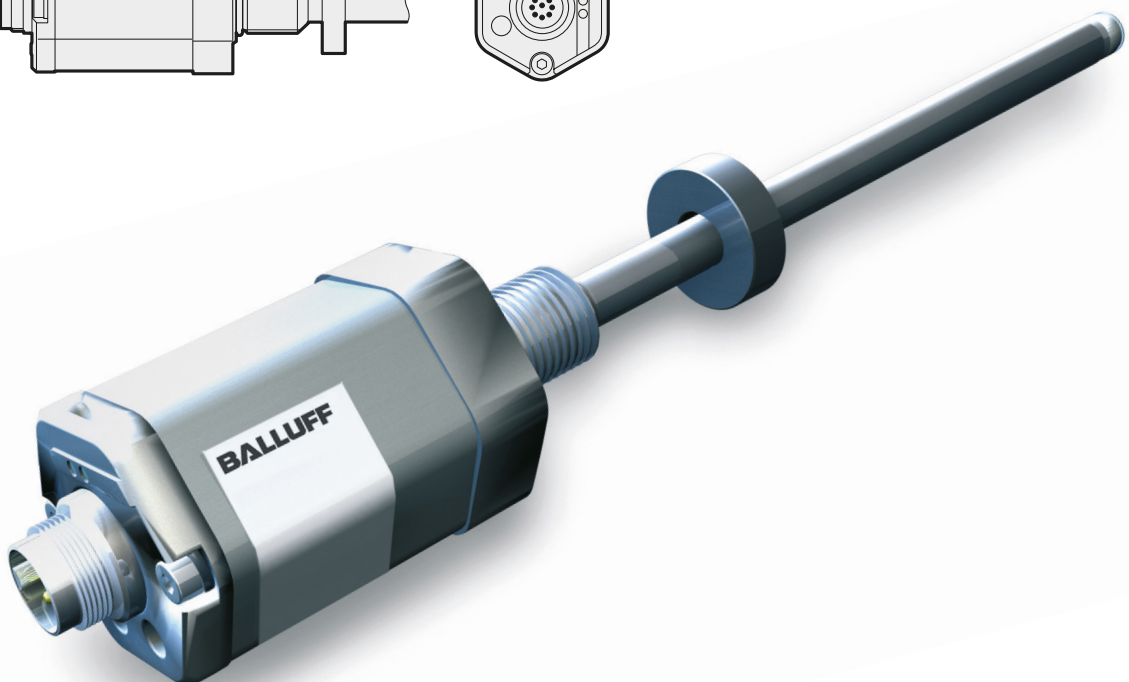
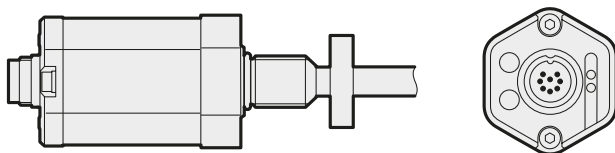

www.balluff.com

1	Notes to the user	5
1.1	Scope	5
1.2	Symbols and conventions	5
1.3	Scope of delivery	5
1.4	Approvals and markings	5
1.5	Abbreviations	5
2	Safety	6
2.1	Intended use	6
2.2	General safety notes for the position measuring system	6
2.3	Explanation of the warnings	6
2.4	Disposal	6
3	Construction and function	7
3.1	Construction	7
3.2	Function	7
3.3	LED display	8
4	Installation and connection	9
4.1	Installation guidelines	9
4.2	Preparing for installation	9
4.3	Installing the transducer	10
4.3.1	Installation recommendation for hydraulic cylinders	10
4.4	Electrical connection	11
4.4.1	Connector type S32	11
4.4.2	Connector type S115	11
4.4.3	Connector type S140	11
4.4.4	Connector type S147	12
4.4.5	Cable connection	12
4.5	Shielding and cable routing	12
5	Startup	13
5.1	Starting up the system	13
5.2	Operating notes	13
6	SSI interface	14
6.1	Principle	14
6.2	Data formats	15
6.3	Faulty SSI query	15
6.4	Synchronous and asynchronous operation	16
7	Configuration using the Micropulse Configuration Tool (only for BTL7-S510(B)-...)	17
7.1	Micropulse Configuration Tool (software)	17
7.2	Connecting the USB communication box	17
7.3	Configuration options	17
8	Technical data	18
8.1	Accuracy	18
8.2	Ambient conditions	18
8.3	Supply voltage	18
8.4	Output	18
8.5	Dimensions, weights	19
8.6	Update rate and clock frequency	20

9	Accessories	21
9.1	Magnets	21
9.2	Mounting nut	21
9.3	Connectors and cables	22
9.3.1	BKS-S32/S33M-00, freely configurable	22
9.3.2	BKS-S232/S233-PU-__, preassembled	22
9.3.3	BKS-S115/S116-PU-__, preassembled	22
9.3.4	BKS-S140-23-00, freely configurable	23
9.3.5	BKS-S147/S148M-00, freely configurable	23
9.4	USB communication box	23
10	Type code breakdown	24
11	Appendix	26
11.1	Converting units of length	26
11.2	Product labels	26

BTL7-S5__ (B)-M____-A/B/Y/Z(8)-S32/S115/S140/S147/KA__/FA__ Micropulse Transducer - Rod Style

1

Notes to the user

1.1 Scope

This guide describes the construction, function and setup options for the BTL7 Micropulse Transducer with SSI interface. It applies to types

BTL7-S5__ (B)-M____-A/B/Y/Z(8)-S32/S115/S140/S147/KA__/FA__ (see Type code breakdown on page 24 or page 25).

The guide is intended for qualified technical personnel. Read this guide before installing and operating the transducer.

1.2 Symbols and conventions

Individual **instructions** are indicated by a preceding triangle.

▶ Instruction 1

Action sequences are numbered consecutively:

1. Instruction 1
2. Instruction 2



Note, tip

This symbol indicates general notes.

1.3 Scope of delivery

- BTL7 transducer
- Condensed guide



The magnets are available in various models and must be ordered separately.

1.4 Approvals and markings



UL approval¹⁾
File no.
E227256

US Patent 5 923 164

The US patent was awarded in connection with this product.

¹⁾ Not for BTL7-...-FA__



The CE Mark verifies that our products meet the requirements of the current EMC Directive.

The transducer meets the requirements of the following product standard:

- EN 61326-2-3 (noise immunity and emission)

Emission tests:

- RF emission
EN 55011

Noise immunity tests:

- Static electricity (ESD)
EN 61000-4-2 Severity level 3
- Electromagnetic fields (RFI)
EN 61000-4-3 Severity level 3
- Electrical fast transients (burst)
EN 61000-4-4 Severity level 3
- Surge
EN 61000-4-5 Severity level 2
- Conducted interference induced
by high-frequency fields
EN 61000-4-6 Severity level 3
- Magnetic fields
EN 61000-4-8 Severity level 4



More detailed information on the guidelines, approvals, and standards is included in the declaration of conformity.

1.5 Abbreviations

SSI Synchronous Serial Interface

2

Safety

2.1 Intended use

The Micropulse Transducer, together with a machine controller (e.g. PLC), comprises a position measuring system. It is intended to be installed into a machine or system. Flawless function in accordance with the specifications in the technical data is ensured only when using original BALLUFF accessories. Use of any other components will void the warranty.

Opening the transducer or non-approved use are not permitted and will result in the loss of warranty and liability claims against the manufacturer.

2.2 General safety notes for the position measuring system

Installation and startup may only be performed by trained specialists with basic electrical knowledge.

Qualified personnel are those who can recognize possible hazards and institute the appropriate safety measures due to their professional training, knowledge, and experience, as well as their understanding of the relevant regulations pertaining to the work to be done.

The **operator** is responsible for ensuring that local safety regulations are observed.

In particular, the operator must take steps to ensure that a defect in the position measuring system will not result in hazards to persons or equipment.

If defects and unresolvable faults occur in the transducer, it should be taken out of service and secured against unauthorized use.

2.3 Explanation of the warnings

Always observe the warnings in these instructions and the measures described to avoid hazards.

The warnings used here contain various signal words and are structured as follows:

SIGNAL WORD
Hazard type and source Consequences if not complied with ▶ Measures to avoid hazards

The individual signal words mean:

NOTICE! Identifies a hazard that could damage or destroy the product .
 DANGER The general warning symbol in conjunction with the signal word DANGER identifies a hazard which, if not avoided, will certainly result in death or serious injury .

2.4 Disposal

- ▶ Observe the national regulations for disposal.

BTL7-S5__ (B)-M____ -A/B/Y/Z(8)-S32/S115/S140/S147/KA__/FA__ Micropulse Transducer - Rod Style

3

Construction and function

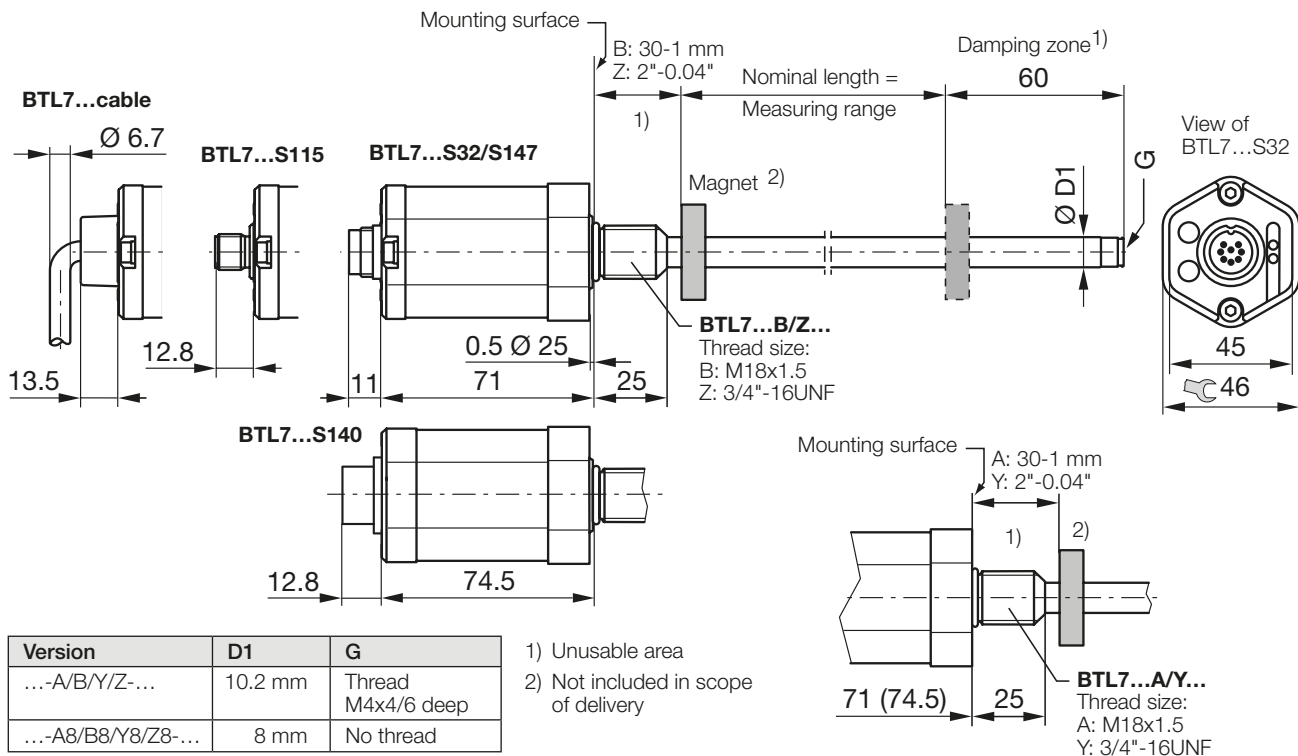

Fig. 3-1: BTL7...A/B/Y/Z(8)... transducer, construction and function

3.1 Construction

Electrical connection: The electrical connection is made via a cable or a connector (see Type code breakdown on page 24 or page 25).

Housing: Aluminum housing containing the processing electronics.

Mounting thread: We recommend assembling the transducer on the fastening screw thread:

- BTL7-...-A/B: M18x1.5
- BTL7-...-Y/Z: 3/4"-16UNF

The transducers with $\varnothing 10.2$ mm have an additional thread at the end of the rod to support larger nominal lengths.

Magnet: Defines the position to be measured on the waveguide. Magnets are available in various models and must be ordered separately (see Accessories on page 21).

Nominal length: Defines the available measuring range. Rods with various nominal lengths from 25 mm to 7620 mm are available depending on the version:

- $\varnothing 10.2$ mm: Nominal length from 25 mm to 7620 mm
- $\varnothing 8$ mm: Nominal length from 25 mm to 1016 mm

Damping zone: Area at the end of the rod that cannot be used for measurements, but which may be passed over.

3.2 Function

The Micropulse Transducer contains the waveguide which is protected by an outer stainless steel tube (rod). A magnet is moved along the waveguide. This magnet is connected to the system part whose position is to be determined. The magnet defines the position to be measured on the waveguide.

An internally generated INIT pulse interacts with the magnetic field of the magnet to generate a torsional wave in the waveguide which propagates at ultrasonic speed.

The component of the torsional wave which arrives at the end of the waveguide is absorbed in the damping zone to prevent reflection. The component of the torsional wave which arrives at the beginning of the waveguide is converted by a coil into an electrical signal. The travel time of the wave is used to calculate the position that is output in antivalent form as synchronous serial data (SSI) on the RS-422 interface. This is done with a high level of precision and reproducibility within the measuring range indicated as the nominal length.

In addition to the position output value, the following functions can be selected (only BTL7-S510(B)-...):

- Differential position
- Speed (with or without leading sign)
- Speed difference

3

Construction and function (continued)

3.3 LED display

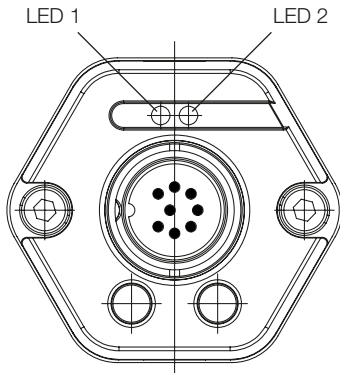

Fig. 3-2: Position of the BTL7 LED displays

LED 1	
Green	Normal function Magnet is within the limits.
Red	Error No magnet or magnet outside the limits.

LED 2	
Green	Synchronous operation¹⁾ Internal measurement is synchronous to SSI query.
Off	Asynchronous operation¹⁾ Internal measurement is asynchronous to SSI query.
Flashing green	Programming mode Only with BTL7-S510(B)-...



Note on configuration (only BTL7-S510(B)-...)

The entire range of functionality can only be configured with the PC software "Micropulse Configuration Tool". To do this, the USB communication box must be connected (see Accessories on page 23).

When reading or writing data via the Micropulse Configuration Tool, LED 2 flashes green to display programming mode.

¹⁾ Asynchronous operation is reached when the external sampling rate is $> f_{A,max}$ or < 62.5 Hz (only with BTL7-S5__B-...), see Technical data on page 20, Fig. 8-1.

Behavior of LED 1 and the error value through the entire range:

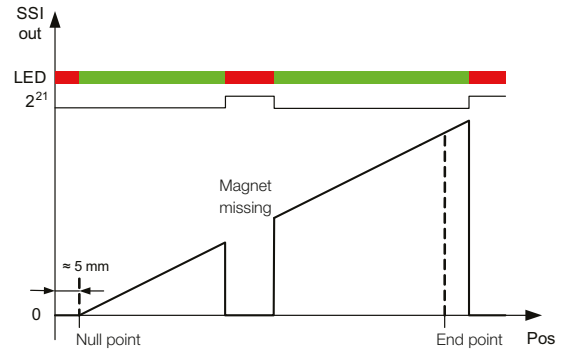

Fig. 3-3: Behavior of LED 1 and error value BTL7 $\geq 5 \mu\text{m}$

For resolutions $\geq 5 \mu\text{m}$, in the case of an error, bit 2^{21} is set. For resolutions $< 5 \mu\text{m}$, there is no error bit and the value 0 is output.

4

Installation and connection

4.1 Installation guidelines

Non-magnetizable material

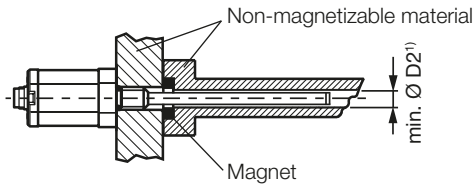

¹) Min. Ø D2 = Minimum diameter of the bore (see Tab. 4-1)

Fig. 4-1: Installation in non-magnetizable material

Magnetizable material

If using magnetizable material, the transducer must be protected against magnetic interference through suitable measures (e.g. spacer ring made of non-magnetizable material, a suitable distance from strong external magnetic fields).

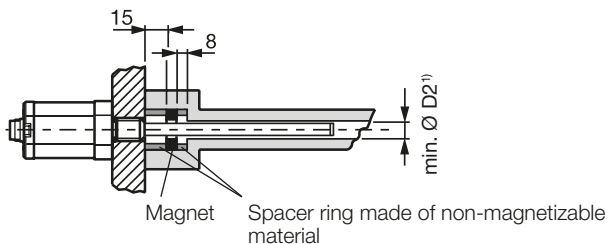
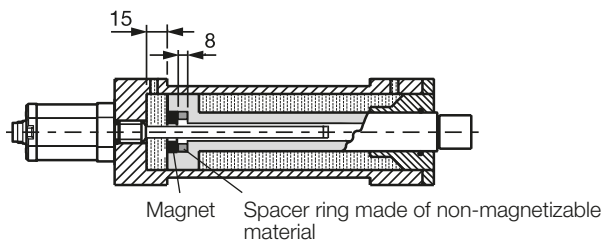

¹) Min. Ø D2 = Minimum diameter of the bore (see Tab. 4-1)

Fig. 4-2: Installation in magnetizable material

Rod diameter	Bore diameter D2
10.2 mm	At least 13 mm
8 mm	At least 11 mm

Tab. 4-1: Bore diameter if installed in a hydraulic cylinder

4.2 Preparing for installation

Installation note: We recommend using non-magnetizable material to mount the transducer and magnet.

Horizontal assembly: for horizontal assembly with nominal lengths > 500 mm, support the rod and tighten it at the end if necessary (only possible with a diameter of 10.2 mm).

Hydraulic cylinder: If installed in a hydraulic cylinder, ensure that the minimum value for the bore diameter of the support piston is complied with (see Tab. 4-1).

Mounting hole: The transducer comes with an M18x1.5 (ISO) or 3/4"-16UNF (SAE) mounting thread. Depending on the version, a mounting hole must be made before assembly.

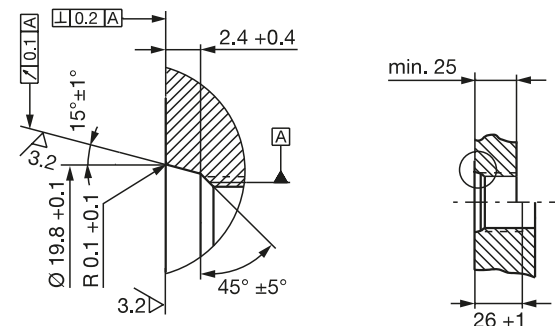

Fig. 4-3: Mounting hole M18x1.5 per ISO 6149 O-ring 15.4x2.1

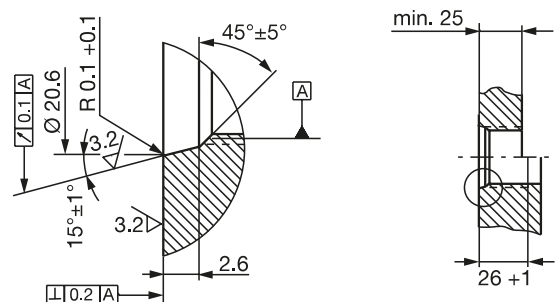

Fig. 4-4: Mounting hole 3/4"-16UNF per SAE J475 O-ring 15.3x2.4

Magnet: Various magnets are available for the BTL7 transducer (see Accessories on page 21).

4

Installation and connection (continued)

4.3 Installing the transducer

NOTICE!

Interference in function

Improper installation can compromise the function of the transducer and result in increased wear.

- ▶ The mounting surface of the transducer must make full contact with the supporting surface.
 - ▶ The bore must be perfectly sealed (O-ring/flat seal).
-
- ▶ Make a mounting hole with thread (possibly with countersink for the O-ring) acc. to Fig. 4-3 or Fig. 4-4.
 - ▶ Screw the transducer with mounting thread into the mounting hole (max. torque 100 Nm).
 - ▶ Install the magnet (accessories).
 - ▶ From 500 mm nominal length: support the rod and tighten it at the end if necessary (only possible with a diameter of 10.2 mm).

i Suitable nuts for the mounting thread are available as accessories (see page 21).

4.3.1 Installation recommendation for hydraulic cylinders

If you seal the hole with a flat seal, the max. operating pressure will be reduced in accordance with the larger pressurized surface.

If installing horizontally in a hydraulic cylinder (nominal lengths > 500 mm), we recommend affixing a sliding element to protect the rod end from wear.

i Dimensioning of the detailed solutions is the responsibility of the cylinder manufacturer.

The sliding element material must be suitable for the appropriate load case, medium used, and application temperatures. E.g. Teflon or bronze are all possible materials.

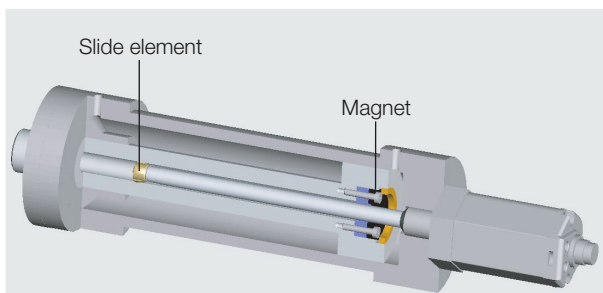

Fig. 4-5: Example 1, transducer installed with sliding element

The sliding element can be screwed on or bonded.

- ▶ Secure the screws so they cannot be loosened or lost.
- ▶ Select a suitable adhesive.

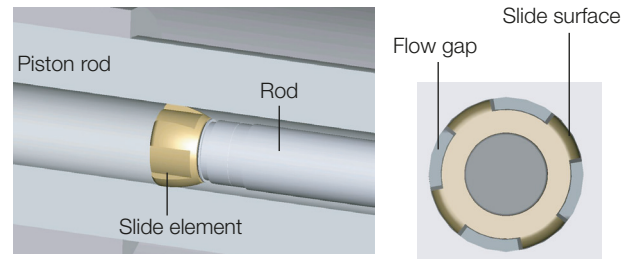

Fig. 4-6: Detailed view and top view of sliding element

There must be a gap between the sliding element and piston bore that is sufficiently large for the hydraulic oil to flow through.

Options for fixing the magnet:

- Screws
- Threaded ring
- Press fitting
- Notches (center punching)

i If installed in a hydraulic cylinder, the magnet should not make contact with the rod.

The hole in the spacer ring must ensure optimum guidance of the rod by the sliding element.

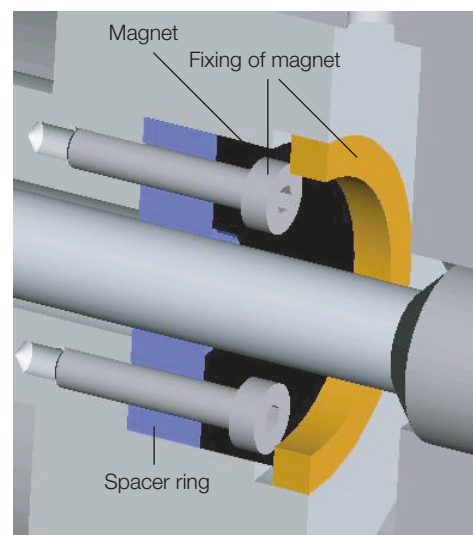

Fig. 4-7: Fixing of magnet

An example of how to install the transducer with a supporting rod is shown in Fig. 4-8 on page 11.

BTL7-S5_(B)-M____-A/B/Y/Z(8)-S32/S115/S140/S147/KA_/FA_ Micropulse Transducer - Rod Style

4

Installation and connection (continued)

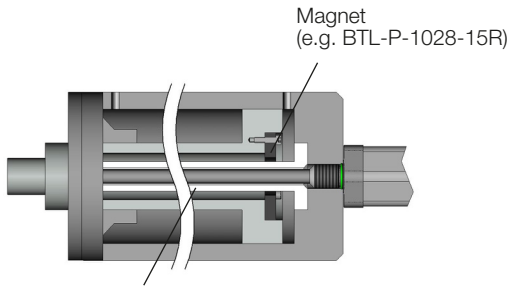

Supporting rod made of non-magnetizable material

Fig. 4-8: Example 2, transducer installed with supporting rod

4.4 Electrical connection

Depending on the model, the electrical connection is made using a cable or a connector.

The connection or pin assignments for the respective version can be found in Tab. 4-2 to Tab. 4-6.



Note the information on shielding and cable routing on page 12.

4.4.1 Connector type S32

	BTL7 standard	BTL7 USB configurable
Pin	BTL7-S5_ _-...-S32 BTL7-S5_ _B-...-S32	BTL7-S510-...-S32 BTL7-S510B-...-S32
1	+Clk	+Clk
2	+Data	+Data
3	-Clk	-Clk
4	Not used ¹⁾	La ²⁾
5	-Data	-Data
6	GND	GND
7	10...30 V	10...30 V
8	Not used ¹⁾	Lb ²⁾

¹⁾ Unassigned leads can be connected to the GND on the controller side but not to the shield.

²⁾ Communication line

Tab. 4-2: Connection assignment BTL7...-S32

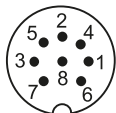

Fig. 4-9: Pin assignment of S32 (view of connector pins of transducer), 8-pin M16 circular plug

4.4.2 Connector type S115

	BTL7 standard	BTL7 USB configurable
Pin	BTL7-S5_ _-...-S115 BTL7-S5_ _B-...-S115	BTL7-S510-...-S115 BTL7-S510B-...-S115
1	+Clk	+Clk
2	+Data	+Data
3	-Clk	-Clk
4	Not used ¹⁾	La ²⁾
5	-Data	-Data
6	GND	GND
7	10...30 V	10...30 V
8	Not used ¹⁾	Lb ²⁾

¹⁾ Unassigned leads can be connected to the GND on the controller side but not to the shield.

²⁾ Communication line

Tab. 4-3: Connection assignment BTL7...-S115

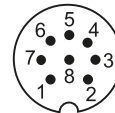

Fig. 4-10: Pin assignment of S115 (view of connector pins of transducer), 8-pin M12 circular plug

4.4.3 Connector type S140

	BTL7 standard	BTL7 USB configurable
Pin	BTL7-S5_ _-...-S140 BTL7-S5_ _B-...-S140	BTL7-S510-...-S140 BTL7-S510B-...-S140
A	+Data	+Data
B	+Clk	+Clk
C	-Clk	-Clk
D	10...30 V	10...30 V
E	Not used ¹⁾	Not used ¹⁾
F	GND	GND
G	Not used ¹⁾	La ²⁾
H	Not used ¹⁾	Lb ²⁾
J	-Data	-Data
K	Not used ¹⁾	Not used ¹⁾

¹⁾ Unassigned leads can be connected to the GND on the controller side but not to the shield.

²⁾ Communication line

Tab. 4-4: Connection assignment BTL7...-S140

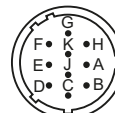

Fig. 4-11: Pin assignment of S140 (view of connector pins of transducer), 10-pin circular plug

4

Installation and connection (continued)

4.4.4 Connector type S147

	BTL7 standard
Pin	BTL7-S5__-...-S147 BTL7-S5__B-...-S147
1	-Data
2	+Data
3	+Clk
4	-Clk
5	10...30 V
6	GND
7	Not used ¹⁾

¹⁾ Unassigned leads can be connected to the GND on the controller side but not to the shield.

Tab. 4-5: Connection assignment BTL7...-S147

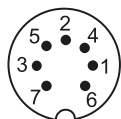

Fig. 4-12: Pin assignment of S147 (view of connector pins of transducer), 7-pin M16 circular plug

4.4.5 Cable connection

	BTL7 standard	BTL7 USB configurable
Cable color	BTL7-S5__-...-KA BTL7-S5__-...-FA BTL7-S5__B-...-KA BTL7-S5__B-...-FA	BTL7-S510-...-KA BTL7-S510-...-FA BTL7-S510B-...-KA BTL7-S510B-...-FA
YE yellow	+Clk	+Clk
GY gray	+Data	+Data
PK pink	-Clk	-Clk
RD red	Not used ¹⁾	La ²⁾
GN green	-Data	-Data
BU blue	GND	GND
BN brown	10...30 V	10...30 V
WH white	Not used ¹⁾	Lb ²⁾

¹⁾ Unassigned leads can be connected to the GND on the controller side but not to the shield.

²⁾ Communication line

Tab. 4-6: Connection assignment BTL7... cable

i Clk, Data and supply are twisted in pairs (see Fig. 4-13).

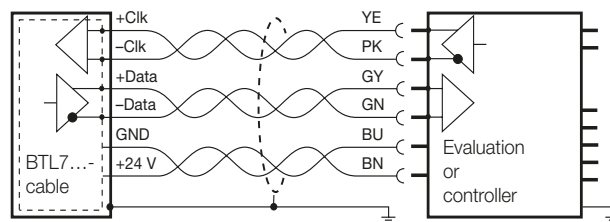

Fig. 4-13: Connection example for BTL7-S...-cable 24 V DC with evaluation/controller

4.5 Shielding and cable routing

i **Defined ground!**
 The transducer and the control cabinet must be at the same ground potential.

Shielding

To ensure electromagnetic compatibility (EMC), observe the following:

- Connect the transducer and controller using a shielded cable.
 Shielding: Copper filament braided, at least 85% coverage
- Connector version: Shield is internally connected to connector housing.
- Cable version: On the transducer side, the cable shielding is connected to the housing.
 Ground the cable shielding on the controller side (connect with the protective earth conductor).

Magnetic fields

The position measuring system is a magnetostrictive system. It is important to maintain adequate distance between the transducer cylinder and strong, external magnetic fields.

Cable routing

Do not route the cable between the transducer, controller, and power supply near high voltage cables (inductive stray noise is possible).
 The cable must be routed tension-free.

Bending radius for fixed cable

The bending radius for a fixed cable must be at least five times the cable diameter.

Cable length

BTL7-S...	Max. 500 m ¹⁾
-----------	--------------------------

¹⁾ Prerequisite: Construction, shielding and routing preclude the effect of any external noise fields. Required cable cross-section $\geq 0.6 \text{ mm}^2$ or $\leq \text{AWG19}$.

Tab. 4-7: Cable length BTL7

i For notes on cable length, see Technical data on page 20, Fig. 8-2.

5

Startup

5.1 Starting up the system

DANGER

Uncontrolled system movement

When starting up, if the position measuring system is part of a closed loop system whose parameters have not yet been set, the system may perform uncontrolled movements. This could result in personal injury and equipment damage.

- ▶ Persons must keep away from the system's hazardous zones.
- ▶ Startup must be performed only by trained technical personnel.
- ▶ Observe the safety instructions of the equipment or system manufacturer.

1. Check connections for tightness and correct polarity. Replace damaged connections.
2. Turn on the system.
3. Check measured values and adjustable parameters and readjust the transducer, if necessary.



Check for the correct values at the null point and end point, especially after replacing the transducer or after repair by the manufacturer.

5.2 Operating notes

- Check the function of the transducer and all associated components on a regular basis.
- Take the position measuring system out of operation whenever there is a malfunction.
- Secure the system against unauthorized use.

6

SSI interface

6.1 Principle

SSI stands for Synchronous Serial Interface and describes a digital synchronous interface with a differential clock line and a differential data line.

With the first falling cycle edge, the data word to be output is buffered in the transducer to ensure data consistency. Data output takes place with the first rising cycle flank, i.e. the transducer supplies a bit to the data line for each rising cycle edge. In doing so, the line capacities and delays of drivers t_v when querying the data bits must be taken into account in the controller.

The max. clock frequency f_{clk} is dependent on the cable length (see Technical data on page 20, Fig. 8-2). The t_m time, also called monoflop time, is started with the last falling edge and is output as the low level with the last rising edge. The data line remains at low until the t_m time has elapsed. Afterwards, the transducer is ready again to receive the next clock package.

With the BTL7-S5__B-M..., position data is determined and output in a timely manner and synchronous to the external sampling period. For synchronous operation, the sampling period T_A must be in the range $T_{A,min} \leq T_A \leq 16 \text{ ms}$. The transducer switches to asynchronous operation outside of this range. If the minimum sampling time is undercut, the transducer outputs the same position value several times. The external sampling rate is then greater than the internal rate. In addition, T_A must be long enough so that the next clock package does not occur in the t_m range of the previous package.

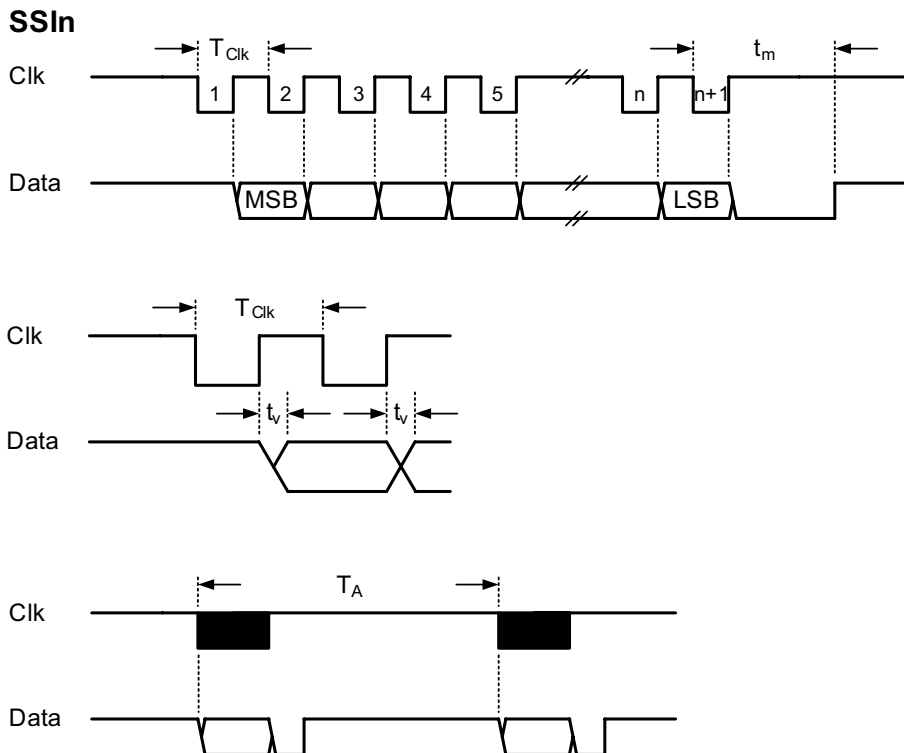

- T_{clk} = $1/f_{clk}$ SSI clock period, SSI clock frequency
- T_A = $1/f_A$ Sampling period, sampling rate
- n Number of bits to be transmitted (requires n+1 clock impulses)
- t_m = $2 \cdot T_{clk}$ Time until the SSI interface is ready again
- t_v = 150 ns Transmission delay times (measured with a 1 m cable)

6

SSI interface (continued)

6.2 Data formats

Standard BTL7 has the following factory settings for position output, which can no longer be changed retroactively:

- SSI24, SSI25 or SSI26
- Binary or Gray coded
- Rising or falling

The contents of the information to be transferred and the error value can be configured with the BTL7-S510(B)-.... Position, speed, or position/speed differences can be sent via Data. The MSB is always transmitted first.

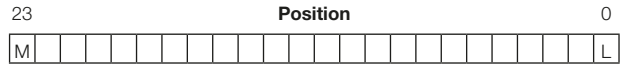

Output of a position via SSI24

M = MSB (Most Significant Bit)
 L = LSB (Least Significant Bit)

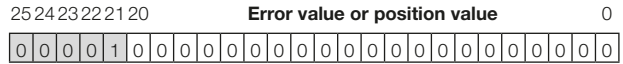

Example of a SSI26 with error bit at bit position 21 and error value 0. The data length there is 21 bit, the total bit number is 26. Four zeros are transmitted before the error bit.

SSI16

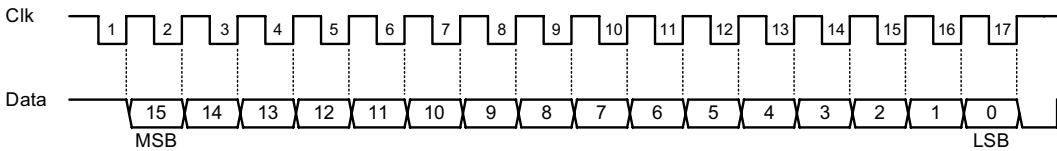

Fig. 6-1: Example of a complete SSI16 data transmission

Depending on the configuration, position or speed data may have a leading sign with the BTL7-S510(B)-.... Negative values are output as a two's complement. With positive speeds, the magnet moves away from the electronics head; with negative speeds it moves towards the electronics head. The controller must be set to process signed data then.

6.3 Faulty SSI query

Underclocking

If there are too few clock edges, the current data level will be maintained for the time t_o ($t_o = 2 \cdot T_{clk}$ Timeout times) after the last negative edge from Clk. If, however, another positive edge occurs, the next bit will then be output. Afterwards, a T_o event will occur internally, the data output switches to low and then back to high after the time t_m has elapsed. The high level is maintained until the next clock burst. Time t_m starts after the end of time t_o .

Overclocking

If there are too many clock edges, the data output will switch to low after the correct number of cycles has been completed. The t_m timer is started again for every additional negative edge from Clk and the T_m event is set internally. Data switches back to high after the time t_m has elapsed.

A T_o or T_m event is displayed in the status field as a communication error in the Micropulse Configuration Tool. In short, a communication error is caused by the following:

- The bit number set in the transducer does not correspond to the bit number in the controller.
 $n_{BTL} > n_{PLC} \rightarrow T_o$ event
 $n_{BTL} < n_{PLC} \rightarrow T_m$ event
- The SSI clock frequency is too low
 $f_{clk} < 9.771 \text{ kHz} \rightarrow T_o$ event
- The pause between two clock packages is too short
 $\rightarrow T_m$ event

6

SSI interface (continued)

6.4 Synchronous and asynchronous operation

Synchronous operation

A uniform and brief timing is often required for control applications. The position delay t_D must be kept as short and constant as possible. Synchronous operation is thus intended for closed control loops. Here, the internal sensing cycle adjusts itself to the external sampling cycle. The following graphic clarifies this relationship:

Two boundary conditions must be taken into account during synchronous operation:

- The external sampling frequency f_A must be in the range $62.5 \text{ Hz} < f_A < f_{A,max}$. The maximum permissible sampling frequency $f_{A,max}$ is shown in Fig. 8-1 on page 20.
- The sampling frequency must be kept as constant as possible.



The sampling frequency is the reciprocal value of the time between two clock packages and may not be confused with the SSI clock frequency.

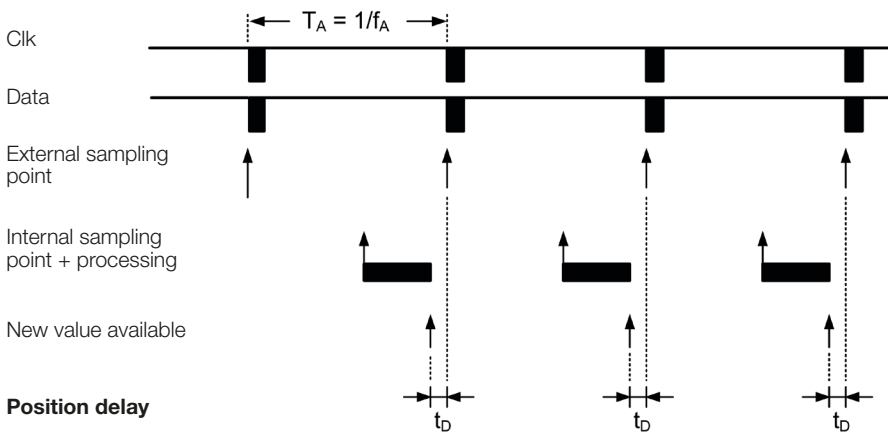

Asynchronous operation

During asynchronous operation, the external sampling frequency is independent of the internal sampling frequency of the transducer. Depending on the external query point, the position is more or less current and the position delay t_D is not constant. In the worst case, it is equal to the internal sampling period. The transducer always works with the maximum possible internal sampling frequency. Due to the measuring principle, the maximum sampling frequency $f_{A,max}$ is dependent on the nominal length of the transducer.

The following graphic shows the behavior of internal and external sampling in asynchronous operation:

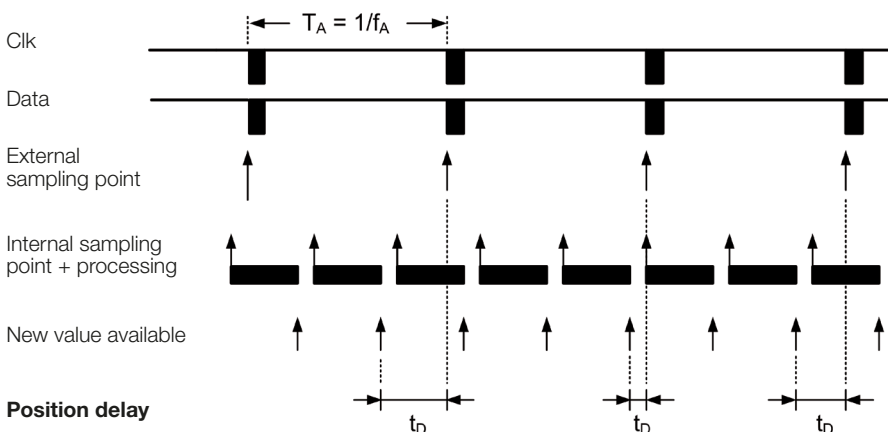

7

Configuration using the Micropulse Configuration Tool (only for BTL7-S510(B)-...)

7.1 Micropulse Configuration Tool (software)

The BTL7-S510(B)-... transducer can be configured quickly and simply on a PC using the Micropulse Configuration Tool PC software.

The most important features include:

- Online display of the current position of the magnet
- Graphic support for setting the functions and characteristics
- Display of information on the connected transducer
- Selection of displayed number formats and units
- Possible to reset to the factory settings
- Demo mode without a connected transducer

i The PC software and associated manual can be found in the Internet under www.balluff.com.

7.2 Connecting the USB communication box

With BTL7-S510(B)-... transducers with a connector (S32/S115/S140), the communication box must be looped in between the transducer and controller. The communication box is connected to the PC via a USB cable.

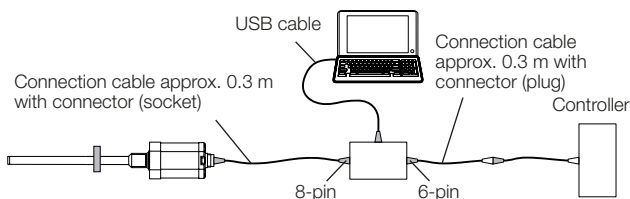

Fig. 7-1: Connecting the communication box with connector

With a BTL7-S510(B)-...-cable transducer, the communication lines La, Lb and GND are connected to the USB communication box.

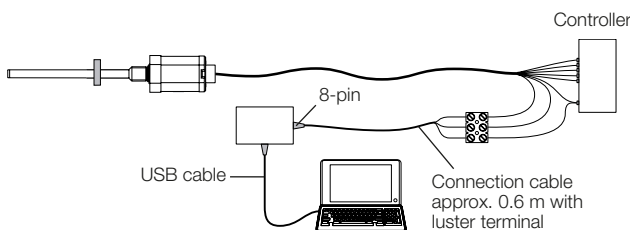

Fig. 7-2: Connecting the communication box with a cable connection

i When reading or writing data via the Configuration Tool, the LED 2 flashes green.

7.3 Configuration options

Prerequisites

- USB communication box connected to the transducer and PC.
- Software correctly installed.
- Transducer connected to the power supply.
- Magnet on transducer.

Output functions

- **Position:** Position in the measuring range.
- **Speed:** Speed of the magnet; the sign indicates the direction of movement. A movement from the starting point to end point is output with a positive sign; a movement from the end point to the starting point is output with a negative sign.
- **Speed (unsigned):** Speed of the magnet, the direction of movement cannot be read.
- **Differential position:** Distance between two magnets. Selection is only possible if two magnets have been selected.
- **Speed difference:** The speeds of two magnets are subtracted to form a sum. Selection is only possible if two magnets have been selected.

Freely configurable characteristic curve

- The gradient of the characteristic curve can be set by adjusting the resolution.
- The limits can be adjusted to the measuring range.
- The error value can be set.

Boundary conditions for several magnets

- Two magnets can only be selected from a nominal length ≥ 90 mm.
- The distance between two magnets must be ≥ 65 mm.

⚠ DANGER

Uncontrolled system movement

When starting up, if the position measuring system is part of a closed loop system whose parameters have not yet been set, the system may perform uncontrolled movements. This could result in personal injury and equipment damage.

- ▶ The system must be taken out of operation before configuration.
- ▶ Transducers may only be connected to the communication box for configuration.
- ▶ The communication box must be removed after configuration.

8

Technical data

8.1 Accuracy

The specifications are typical values for BTL7-S... at 24 V DC, at room temperature, and with a nominal length of 500 mm in conjunction with the BTL-P-1013-4R, BTL-P-1013-4S, BTL-P-1012-4R or BTL-P-1014-2R magnet.

The transducer is fully operational immediately, with full accuracy after warm-up.



For special versions, other technical data may apply.
 Special versions are indicated by the suffix -SA on the part label.

Position resolution	1, 2, 5, 10, 20, 40, 50, 100 µm (additionally 200, 500, 1000 µm with BTL7-S510(B)-...)
Non-linearity at	
Nominal length 25...5500 mm	
resolution ≤ 10 µm	≤ ±30 µm
resolution > 10 µm	≤ ±2 LSB
Nominal length 5501...7620 mm	±0,02 %
Hysteresis	≤ ±7 µm
Repeat accuracy	≤ ±5 µm (typ. ±2.5 µm)
Temperature coefficient ¹⁾	≤ 15 ppm/K
Speed resolution	0.1 mm/s
Min. detectable speed	1 mm/s
Max. detectable speed	10 m/s

8.2 Ambient conditions²⁾

Operating temperature	-40°C...+85°C
Operating temperature for UL (only BTL7...-KA...)	Max. +80°C
Storage temperature	-40°C...+100°C
Relative humidity	< 90%, non-condensing
Rod pressure rating (when installed in hydraulic cylinders)	
For Ø 8 mm	≤ 250 bar
For Ø 10.2 mm	≤ 600 bar
Shock rating	150 g/6 ms
Continuous shock per EN 60068-2-27 ³⁾	150 g/2 ms

Vibration 20 g, 10...2000 Hz per EN 60068-2-6³⁾ (note resonant frequency of the rod)

Degree of protection per IEC 60529	
Connector S32/S115/S147 (when attached)	IP67
Connector S140 (when attached)	IP65
Cable	IP68 ³⁾

8.3 Supply voltage

Voltage, stabilized ⁴⁾	10...30 V DC
Ripple	≤ 0.5 V _{ss}
Current draw (at 24 V DC)	≤ 120 mA
Inrush current	≤ 500 mA
Reverse polarity protection	Up to 36 V (supply to GND)
Overvoltage protection	Up to 36 V
Dielectric strength (GND to housing)	500 V DC

8.4 Communication lines La, Lb

Short-circuit protection Signal cable to GND

¹⁾ Nominal length 500 mm, magnet in the middle of the measuring range

²⁾ For : Use in enclosed spaces and up to a height of 2000 m above sea level.

³⁾ Individual specifications as per Balluff factory standard, resonances excluded

⁴⁾ For : The transducer must be externally connected via a limited-energy circuit as defined in UL 61010-1, a low-power source as defined in UL 60950-1, or a class 2 power supply as defined in UL 1310 or UL 1585.

BTL7-S5__ (B)-M____-A/B/Y/Z(8)-S32/S115/S140/S147/KA__/FA__ Micropulse Transducer - Rod Style

8

Technical data (continued)

8.5 Output

Configurable bit number (only BTL7-S510(B)-...)	16-32
Coding	Binary or Gray
Characteristic	Rising or falling
SSI data	Position, speed, absolute speed, differential position, speed difference (between 2 magnets), error value
SSI clock frequency f_{clk}	10 kHz...1 MHz
Behavior at null point	BTL7 standard: No negative values between flange and null point BTL7-S510(B)-...: Configurable
Short-circuit protection	Signal lines Data+/-, Clk+/- to +36 V or GND

8.6 Dimensions, weights

Rod diameter	8 mm or 10.2 mm
Nominal length	
For Ø 8 mm	25...1016 mm
For Ø 10.2 mm	25...7620 mm
Weight (depends on length)	Approx. 2 kg/m
Housing material	Aluminum
Flange material	Stainless steel
Rod material	Stainless steel
Rod wall thickness	
For Ø 8 mm	0.9 mm
For Ø 10.2 mm	2 mm
Young's modulus	Approx. 200 kN/mm ²
Housing mounting via threads	M18×1.5 or 3/4"-16UNF
Tightening torque	Max. 100 Nm

BTL7-...-KA__

Cable material	PUR cULus 20549 80 °C, 300 V, internal wiring
Cable temperature	-40°C...+90°C
Cable diameter	Max. 7 mm
Permissible bending radius	
Fixed routing	≥ 35 mm
Movable	≥ 105 mm

BTL7-...-FA__

Cable material	PTFE No UL approval available
Cable temperature	-55°C...+200°C
Cable diameter	Max. 7 mm
Permissible bending radius	
Fixed routing	≥ 35 mm
Movable	No permissible bending radius

8.7 Connection to the evaluation unit

The maximum sampling frequency $f_{A,max}$, at which a new current value is available with each sampling, can be found in the following graphic:

The minimum sampling frequency $f_{A,min}$ is 62,5 Hz.

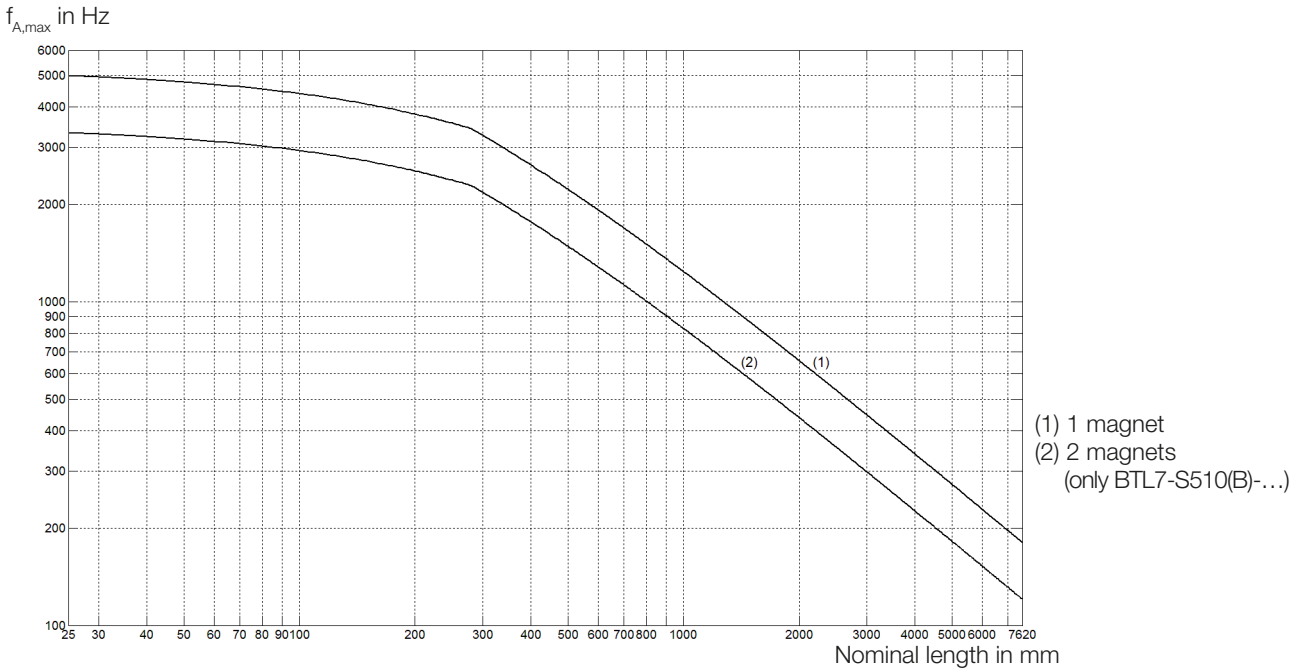

Fig. 8-1: Maximum sampling rate depending on the nominal length (for position output) The maximum sampling rate for velocity output is limited to 3.3 kHz.

The maximum SSI clock frequency $f_{CLK,max}$ is dependent on the cable length¹⁾:

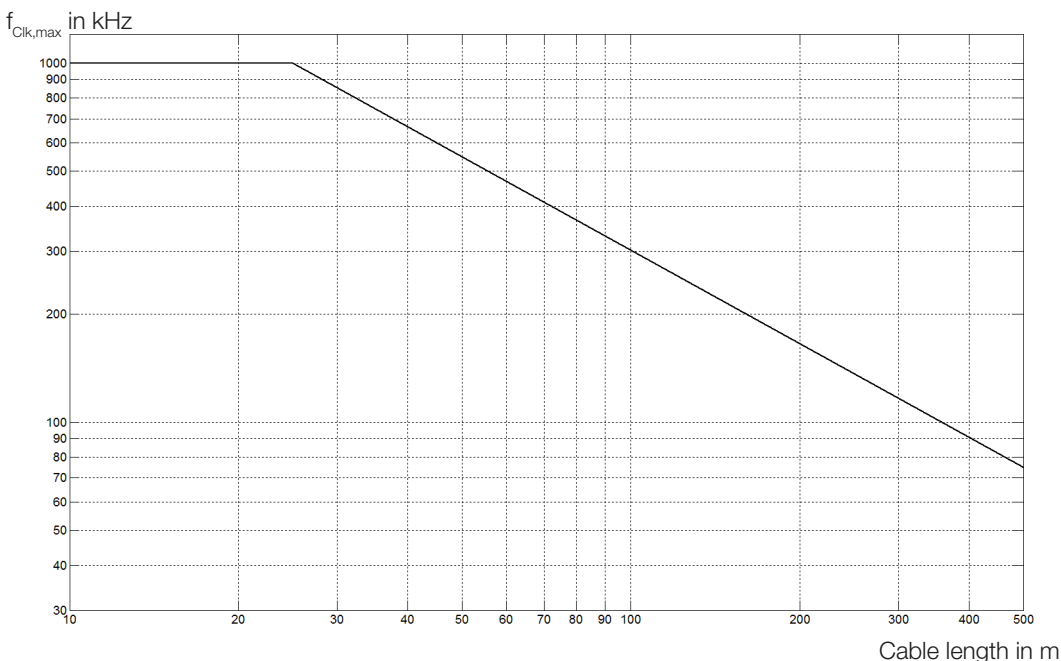

Fig. 8-2: Maximum SSI clock frequency depending on the cable length

¹⁾ For longer length: required cable cross-section $\geq 0.6 \text{ mm}^2$ or $\leq \text{AWG19}$

9

Accessories

Accessories are not included in the scope of delivery and must be ordered separately.

9.1 Magnets

BTL-P-1013-4R

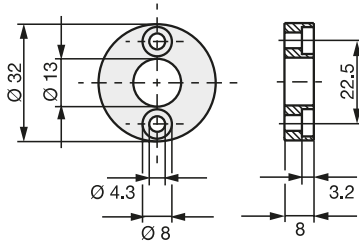

BTL-P-1013-4S

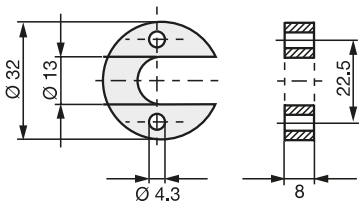

BTL-P-1012-4R

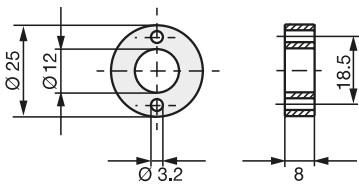

BTL-P-1014-2R

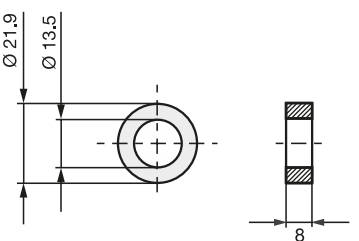

BTL-P-1013-4R, BTL-P-1013-4S, BTL-P-1012-4R, BTL-P-1014-2R:

Weight: Approx. 10 g
 Housing: Aluminum

The scope of delivery for BTL-P-1013-4R, BTL-P-1013-4S, BTL-P-1012-4R magnets includes:

Spacer: 8 mm, material: polyoxymethylene (POM)

BTL5-P-4500-1 magnet (solenoid):

Weight: Approx. 90 g
 Housing: Plastic
 Operating temperature: -40°C...+60°C

BTL-P-1028-15R (special accessories for applications with a supporting rod):

Weight: Approx. 68 g
 Housing: Aluminum

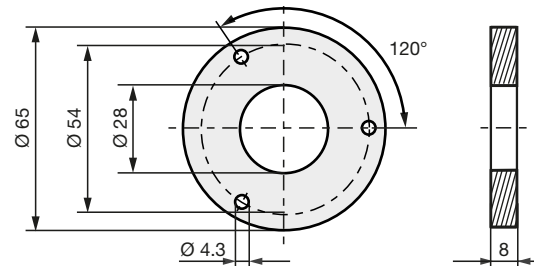

9.2 Mounting nut

- Mounting nut M18x1.5:
BTL-A-FK01-E-M18x1.5
- 3/4"-16UNF mounting nut:
BTL-A-FK01-E-3/4"-16UNF

Fig. 9-1: Magnet installation dimensions

9

Accessories (continued)

9.3 Connectors and cables

9.3.1 BKS-S32/S33M-00, freely configurable

BKS-S32M-00

Straight connector, freely configurable
 M16 per IEC 130-9, 8-pin

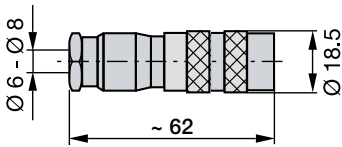

Fig. 9-2: Connector BKS-S32M-00

BKS-S33M-00

Angled connector, freely configurable
 M16 per IEC 130-9, 8-pin

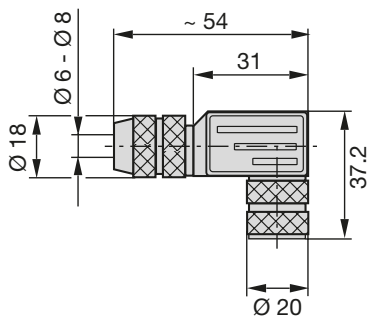

Fig. 9-3: Connector BKS-S33M-00

9.3.2 BKS-S232/S233-PU-__, preassembled

BKS-S232-PU-__

Straight connector, molded, preassembled
 M16, 8-pin
 Various cable lengths can be ordered, e.g.
 BKS-S232-PU-05: Cable length 5 m

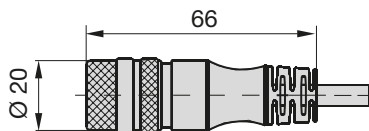

Fig. 9-4: Connector BKS-S232-PU-__

BKS-S233-PU-__

Angled connector, molded, preassembled
 M16, 8-pin
 Various cable lengths can be ordered, e.g.
 BKS-S233-PU-05: Cable length 5 m

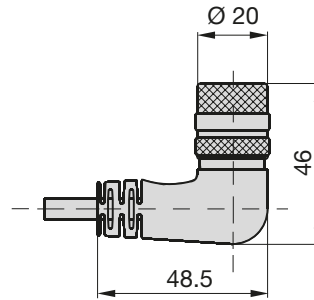

Fig. 9-5: Connector BKS-S233-PU-__

Pin	Color
1	YE yellow
2	GY gray
3	PK pink
4	RD red
5	GN green
6	BU blue
7	BN brown
8	WH white

Tab. 9-1: BKS-S232/S233-PU-__ pin assignment

9.3.3 BKS-S115/S116-PU-__, preassembled

BKS-S115-PU-__

Straight connector, molded-on cable, preassembled
 M12, 8-pin
 Various cable lengths can be ordered, e.g.
 BKS-S115-PU-05: Cable length 5 m

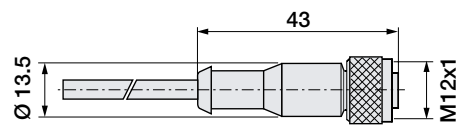

Fig. 9-6: Connector BKS-S115-PU-__

BTL7-S5__ (B)-M____-A/B/Y/Z(8)-S32/S115/S140/S147/KA__/FA__ Micropulse Transducer - Rod Style



Accessories (continued)

BKS-S116-PU-__

Angled connector, molded-on cable, preassembled M12, 8-pin

Various cable lengths can be ordered, e.g.

BKS-S116-PU-05: Cable length 5 m

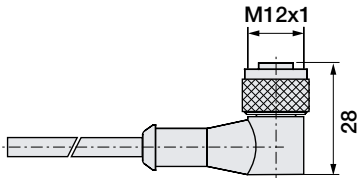

Fig. 9-7: Connector BKS-S116-PU-__

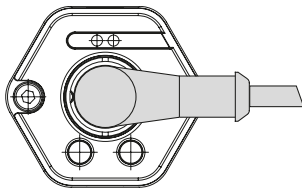

Fig. 9-8: Connector BKS-S116-PU-__, outlet

Pin	Color
1	YE yellow
2	GY gray
3	PK pink
4	RD red
5	GN green
6	BU blue
7	BN brown
8	WH white

Tab. 9-2: BKS-S115/S116-PU-__ pin assignment

9.3.4 BKS-S140-23-00, freely configurable

BKS-S140-23-00

Straight connector, field attachable 10-pin

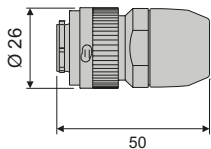

Fig. 9-9: Connector type BKS-S140-23-00

9.3.5 BKS-S147/S148M-00, freely configurable

BKS-S147M-00

Straight connector, field attachable

M16 per IEC 130-9, 7-pin

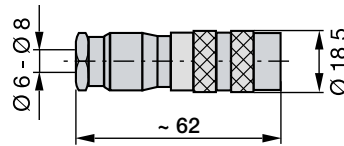

Fig. 9-10: Connector type BKS-S147M-00

BKS-S148M-00

Angled connector, field attachable

M16 per IEC 130-9, 7-pin

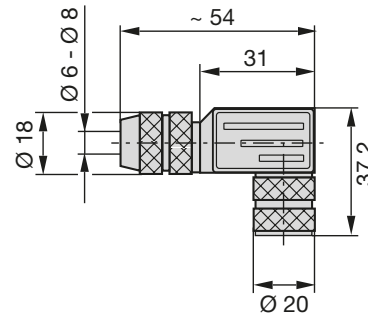

Fig. 9-11: Connector type BKS-S148M-00

9.4 USB communication box

BTL7-A-CB01-USB-S32

For BTL7-S510(B)-... with connector type S32.

Scope of delivery: USB communication box, USB cable, 2 adapter cables each approx. 0.3 m, condensed guide.

BTL7-A-CB01-USB-S115

For BTL7-S510(B)-... with connector type S115.

Scope of delivery: USB communication box, USB cable, 2 adapter cables each approx. 0.3 m, condensed guide.

BTL7-A-CB01-USB-S140

For BTL7-S510(B)-... with connector type S140.

Scope of delivery: USB communication box, USB cable, 2 adapter cables each approx. 0.3 m, condensed guide.

BTL7-A-CB01-USB-KA

For BTL7-S510(B)-... with cable connection.

Scope of delivery: USB communication box, USB cable, 1 adapter cable each approx. 0.6 m, condensed guide.

10 Type code breakdown

BTL7 standard

BTL7 - S 5 0 1 B - M0500 - B - S32

Micropulse transducer

SSI interface

Supply voltage:

5 = 10...30 V DC

Data format:

24 bit

25 bit

26 bit

0 = Binary, rising

6 = Binary, rising

A = Binary, rising

1 = Gray, rising

7 = Gray, rising

B = Gray, rising

2 = Binary, falling

8 = Binary, falling

C = Binary, falling

3 = Gray, falling

9 = Gray, falling

D = Gray, falling

Resolution:

1 = 1 µm

3 = 10 µm

5 = 40 µm

7 = 2 µm

2 = 5 µm

4 = 20 µm

6 = 100 µm

8 = 50 µm

Synchronous/asynchronous operation:

B = synchronous operation

without B = asynchronous operation

Nominal length (4-digit):

M0500 = Metric specification in mm, nominal length 500 mm

(M0025...M1016: A8, B8, Y8, Z8)

(M0025...M7620: A, B, Y, Z)

Rod version, fastening:

A = Metric mounting thread M18x1.5, O-ring, rod diameter 10.2 mm

B = Metric mounting thread M18x1.5, O-ring, rod diameter 10.2 mm

Y = 3/4"-16UNF thread, O-ring, rod diameter 10.2 mm

Z = 3/4"-16UNF thread, O-ring, rod diameter 10.2 mm

A8 = Metric mounting thread M18x1.5, O-ring, rod diameter 8 mm

B8 = Metric mounting thread M18x1.5, O-ring, rod diameter 8 mm

Y8 = 3/4"-16UNF thread, O-ring, rod diameter 8 mm

Z8 = 3/4"-16UNF thread, O-ring, rod diameter 8 mm

Electrical connection:

S32 = 8-pin, M16 plug per IEC 130-9

S115 = 8-pin, M12 plug

S140 = 10-pin, plug

S147 = 7-pin, M16 plug acc. to DIN 45329

KA05 = Cable, 5 m (PUR)

FA05 = Cable, 5 m (PTFE)

BTL7-S5__ (B)-M____-A/B/Y/Z(8)-S32/S115/S140/S147/KA__/FA__
Micropulse Transducer - Rod Style

10 Type code breakdown (continued)

BTL7 USB configurable

BTL7 - S 5 1 0 B - M0500 - B - S32

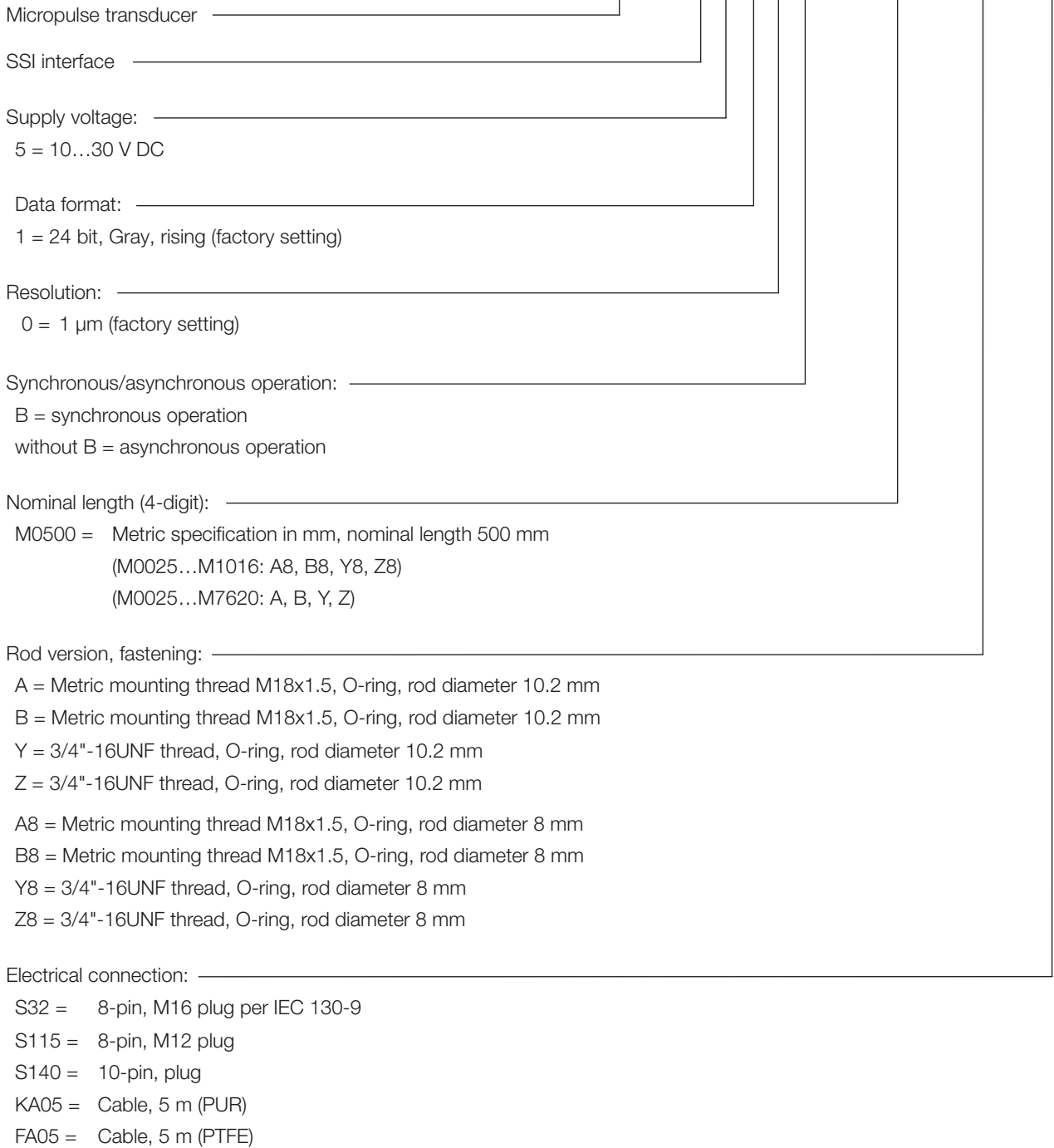

11 Appendix

11.1 Converting units of length

1 mm = 0.0393700787 inch

mm	inches
1	0.03937008
2	0.07874016
3	0.11811024
4	0.15748031
5	0.19685039
6	0.23622047
7	0.27559055
8	0.31496063
9	0.35433071
10	0.393700787

Tab. 11-1: Conversion table mm to inches

1 inch = 25.4 mm

inches	mm
1	25.4
2	50.8
3	76.2
4	101.6
5	127
6	152.4
7	177.8
8	203.2
9	228.6
10	254

Tab. 11-2: Conversion table inches to mm

11.2 Product labels



Fig. 11-1: Standard BTL7 product label



Fig. 11-2: BTL7-S510-... product label

 **www.balluff.com**

Headquarters

Germany

Balluff GmbH
Schurwaldstrasse 9
73765 Neuhausen a.d.F.
Phone + 49 7158 173-0
Fax +49 7158 5010
balluff@balluff.de

Global Service Center

Germany

Balluff GmbH
Schurwaldstrasse 9
73765 Neuhausen a.d.F.
Phone +49 7158 173-370
Fax +49 7158 173-691
service@balluff.de

US Service Center

USA

Balluff Inc.
8125 Holton Drive
Florence, KY 41042
Phone (859) 727-2200
Toll-free 1-800-543-8390
Fax (859) 727-4823
technicalsupport@balluff.com

CN Service Center

China

Balluff (Shanghai) trading Co., Ltd.
Room 1006, Pujian Rd. 145.
Shanghai, 200127, P.R. China
Phone +86 (21) 5089 9970
Fax +86 (21) 5089 9975
service@balluff.com.cn