

BTL6-P11 _-M_ _ _-A1-S115

User's Guide

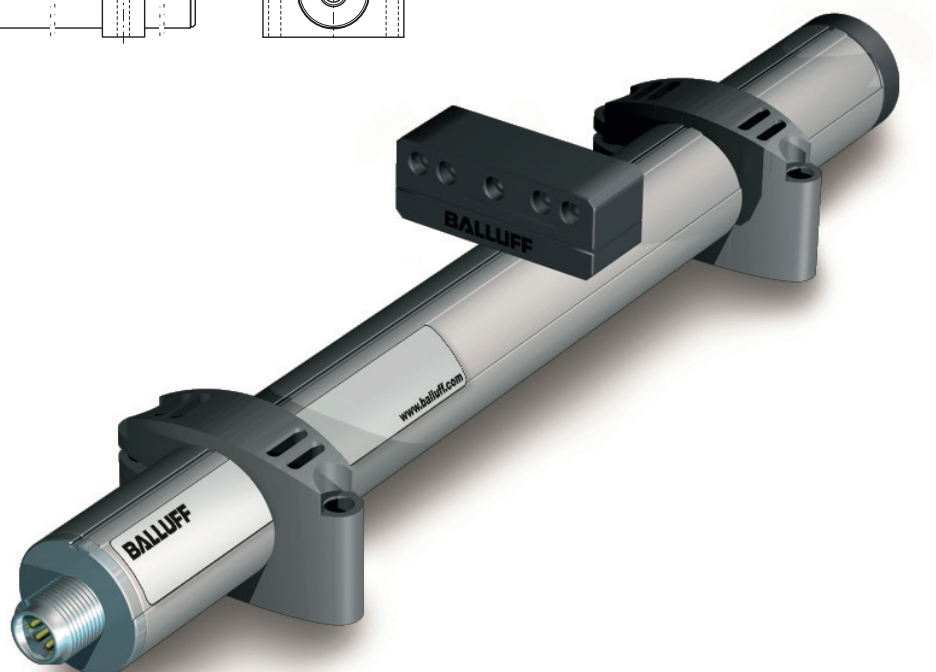
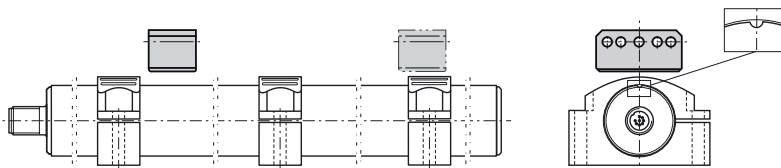

www.balluff.com

1	Notes to the user	4
1.1	Validity	4
1.2	Symbols and conventions	4
1.3	Scope of delivery	4
1.4	Approvals and markings	4
2	Safety	5
2.1	Intended use	5
2.2	General safety notes	5
2.3	Explanation of the warnings	5
2.4	Disposal	5
3	Construction and function	6
3.1	Construction	6
3.2	Function	6
4	Installation and connection	7
4.1	Installing the BTL	7
4.2	Electrical Connection	8
4.3	Shielding and cable routing	8
5	Startup	9
5.1	Starting up the system	9
5.2	Operating notes	9
6	P interface	10
6.1	Principle	10
6.2	DPI/IP method	10
7	Technical data	12
7.1	Accuracy	12
7.2	Ambient conditions	12
7.3	Power supply	12
7.4	Output	12
7.5	Dimensions, weights	12
8	Accessories	13
8.1	Magnets	13
8.2	Mounting brackets/cuff	13
8.3	Connectors	14
9	Type code	15
10	Appendix	16
10.1	Converting units of length	16
10.2	Part label	16

BTL6-P11_-M____-A1-S115

Magnetostrictive Linear Position Sensor – Profile Style

1

Notes to the user

1.1 Validity

This guide describes the construction, function and setup options for the BTL magnetostrictive linear position sensor with digital interface. It applies to models

BTL6-P11_-M____-A1-S115 (see part numbering on page 15).

The guide is intended for qualified technical personnel. Read this guide before installing and operating the BTL.

1.2 Symbols and conventions

Individual **actions** are indicated by a preceding triangle.

- ▶ Instruction 1
- ⇒ Result

Action sequences are numbered consecutively:

1. Instruction 1
2. Instruction 2



Note, tip

This symbol indicates general notes.

1.3 Scope of delivery

- BTL
- Condensed guide



The magnets are available in various models and must be ordered separately.

1.4 Approvals and markings



UL approval
File no.
E227256

US Patent 5 923 164

The US patent was awarded in connection with this product.



The CE Mark verifies that our products meet the requirements of the current EMC Directive.

The BTL meets the requirements of the following product standard:

- EN 61326-2-3 (noise immunity and emission)

Emission tests:

- RF emission
EN 55011

Noise immunity tests:

- Static electricity (ESD)
EN 61000-4-2 Severity level 3
- Electromagnetic fields (RFI)
EN 61000-4-3 Severity level 3
- Electrical fast transients (burst)
EN 61000-4-4 Severity level 3
- Surge
EN 61000-4-5 Severity level 2
- Conducted interference induced by high-frequency fields
EN 61000-4-6 Severity level 3
- Magnetic fields
EN 61000-4-8 Severity level 4



More detailed information on the guidelines, approvals, and standards is included in the declaration of conformity.

2

Safety

2.1 Intended use

The BTL magnetostrictive linear position sensor, together with a machine controller (e.g. PLC), comprises a position measuring system. It is intended to be installed into a machine or system and used in the industrial sector. Flawless function in accordance with the specifications in the technical data is ensured only when using original Balluff accessories. Use of any other components will void the warranty.

Opening the BTL or non-approved use are not permitted and will result in the loss of warranty and liability claims against the manufacturer.

2.2 General safety notes

Installation and **startup** may only be performed by trained specialists with basic electrical knowledge.

Qualified personnel are persons whose technical training, knowledge and experience as well as knowledge of the relevant regulations allows him to assess the work assigned to him, recognize possible hazards and take appropriate safety measures.

The **operator** is responsible for ensuring that local safety regulations are observed.

In particular, the operator must take steps to ensure that a defect in the BTL will not result in hazards to persons or equipment.

If defects and unresolvable faults occur in the BTL, take it out of service and secure against unauthorized use.

2.3 Explanation of the warnings

Always observe the warnings in these instructions and the measures described to avoid hazards.

The warnings used here contain various signal words and are structured as follows:

SIGNAL WORD
<p>Type and source of the hazard Consequences if not complied with ► Measures to avoid hazards</p>

The individual signal words mean:

NOTICE
<p>Identifies a danger that could damage or destroy the product.</p>
 DANGER
<p>The general warning symbol in conjunction with the signal word DANGER identifies a hazard which, if not avoided, will certainly result in death or serious injury.</p>

2.4 Disposal

- Observe the national regulations for disposal.

BTL6-P11_-M____-A1-S115 Magnetostrictive Linear Position Sensor – Profile Style

3

Construction and function

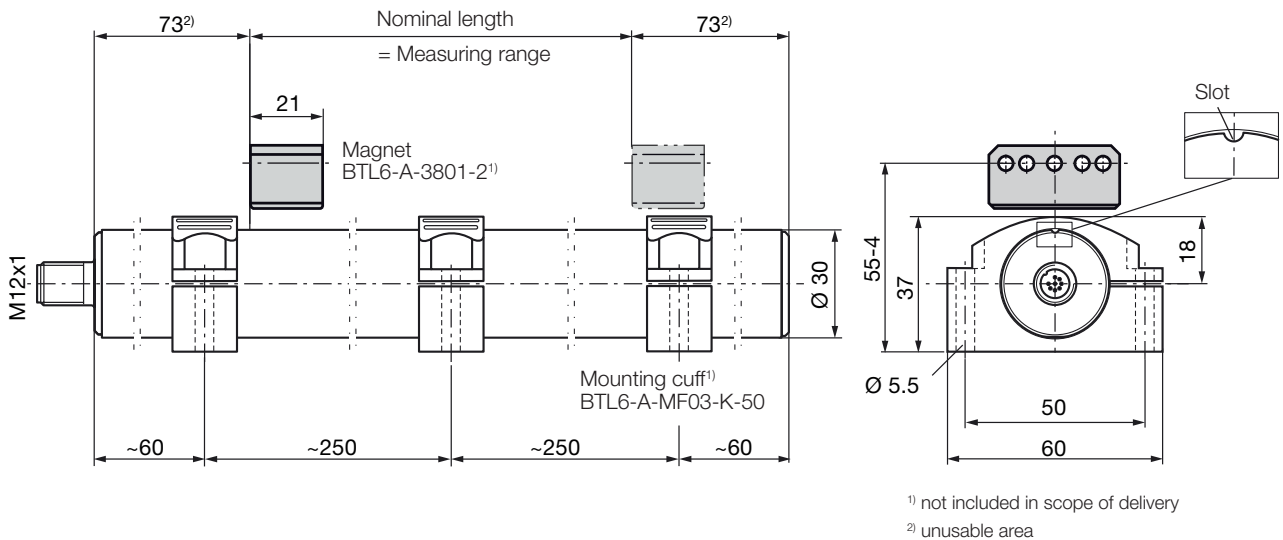

Fig. 3-1: BTL6..., construction

3.1 Construction

Electrical Connection: The electrical connection is made using a connector.

Housing: Aluminum, contains the processing electronics.

Magnet: Defines the position to be measured on the waveguide. Magnets are available in various models and must be ordered separately (see Accessories on page 13).

Nominal length: The following standard nominal lengths are available for compatibility with any application:

	Nominal length
BTL6-P11_-...	50...4012 mm

3.2 Function

The BTL contains the waveguide which is protected by an aluminum housing. A magnet is moved along the waveguide. This magnet is connected to the system part whose position is to be determined. The magnet defines the position to be measured on the waveguide.

An externally generated INIT pulse interacts with the magnetic field of the magnet to generate a torsional wave in the waveguide which propagates at ultrasonic velocity.

The component of the torsional wave which arrives at the end of the waveguide is absorbed in the damping zone to prevent reflection. The component of the torsional wave which arrives at the beginning of the waveguide is converted by a coil into an electrical signal. The travel time of the wave is used to calculate the position. The position value corresponds to the travel time of the torsional wave and is output as digital time information between the start and stop pulses.

The evaluation may relate to the rising or falling edge. This is done with a high level of precision and reproducibility within the measuring range indicated as the nominal length.

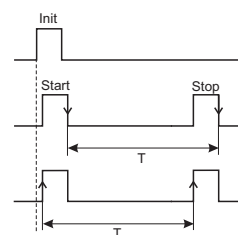

Fig. 3-2: Time/distance measuring principle

BTL6-P11 _-M _ _ _ -A1-S115 Magnetostrictive Linear Position Sensor – Profile Style

4

Installation and connection

4.1 Installing the BTL

NOTICE

Improper installation

Improper installation can compromise the function of the BTL and result in damage.

- ▶ Ensure that no strong electrical or magnetic fields are present in the direct vicinity of the BTL.
- ▶ Be sure to maintain the specified distances and separations.

Note when installing the magnet:

- To ensure the accuracy of the magnetostrictive linear position sensor, fasten the magnet to the moving member of the machine only using non-magnetizable screws (stainless steel, brass, aluminum).
- The moving member must guide the magnet on a parallel line to the BTL.
- Distance A between the magnet and parts made of magnetizable material must be kept to at least 10 mm (see Fig. 4-1 and Fig. 4-2).
- For distance B between the magnet and the BTL and for the center offset C (see Fig. 4-1 and Fig. 4-2) the following values must be maintained:

Magnet type	Distance B ¹⁾	Offset C
BTL6-A-3800-2	4...8 mm ²⁾	± 5 mm
BTL6-A-3801-2	4...8 mm ²⁾	± 5 mm

¹⁾ The selected distance must remain constant over the entire stroke length.

²⁾ For optimal measuring results a distance B of 6...8 mm is recommended.

Tab. 4-1: Distance and offset for magnets (see Fig. 4-1 and Fig. 4-2)

- When using multiple magnets a minimum separation of 65 mm must be maintained between them (see Fig. 4-3).

The BTL is installed on a flat surface of the machine using mounting clamps or cuffs (available accessories). Any orientation is permitted. Note the recommended spacing for the location of clamps or cuffs (see Fig. 3-1 on page 6).

1. Slide BTL into the mounting clamps or cuffs.
2. Align BTL slot in the direction of the magnet(s)!
3. Attach the BTL to the base (tighten screws in clamps or cuffs to max. 4 Nm tightening torque).
4. Installing magnet (accessory).



Check orientation of the BTL. If the slot is not in the direction of the magnet, the mounting screws must be loosened and steps 2 and 3 repeated.

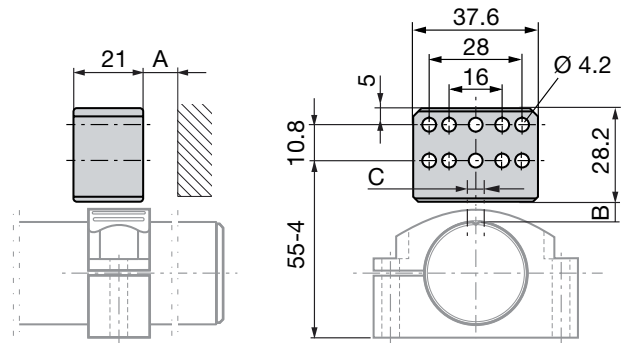

Fig. 4-1: Dimensions and spacing with magnet BTL6-A-3800-2

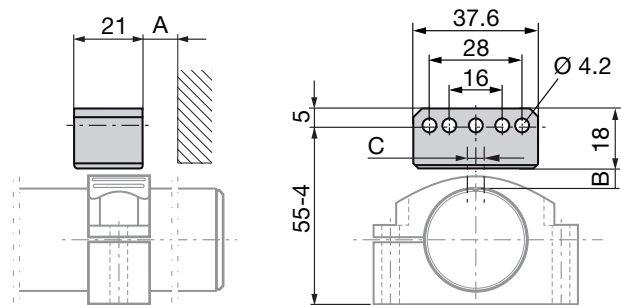

Fig. 4-2: Dimensions and spacing with magnet BTL6-A-3801-2

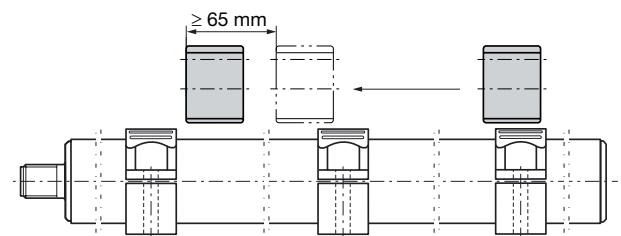

Fig. 4-3: Minimum spacing when using multiple magnets

4 Installation and connection (continued)

4.2 Electrical Connection

The BTL is connected using a plug connection (see Accessories on page 14).

Pin	BTL6-P11_-...
1	+Init
2	+Start/Stop
3	-Init
4	Must remain free
5	-Start/Stop
6	GND ¹⁾
7	20...28 V
8	Must remain free

¹⁾ Reference potential for supply voltage and EMC-GND.

Tab. 4-2: Pin assignment of S115

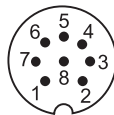

Fig. 4-4: Pin assignment of S115 (view from above on BTL connector), 8-pin M12 circular plug

4.3 Shielding and cable routing

i Defined ground!
 The BTL and the control cabinet must be at the same ground potential.

Shielding

To ensure electromagnetic compatibility (EMC), observe the following:

- Connect BTL and controller using a shielded cable. Shielding: Braided copper shield with minimum 85% coverage.
- Shield is internally connected to connector housing.

Magnetic fields

The position measuring system is a magnetostrictive system.

Be sure to provide sufficient distance of the BTL from strong external magnetic fields.

Cable routing

Do not route the cable between the BTL, controller, and power supply near high voltage cables (inductive stray noise is possible).

The cable must be routed tension-free.

Cable length

BTL6-P...	Max. 500 m ¹⁾
-----------	--------------------------

¹⁾ Longer cables may be used if their construction, shielding and routing prevent noise interference.

Tab. 4-3: Cable length BTL6-P...

5**Startup****5.1 Starting up the system****⚠ DANGER****Uncontrolled system movement**

When starting up, if the position measuring system is part of a closed loop system whose parameters have not yet been set, the system may perform uncontrolled movements. This could result in personal injury and equipment damage.

- ▶ Persons must keep away from the system's hazardous zones.
- ▶ Startup must be performed only by trained technical personnel.
- ▶ Observe the safety instructions of the equipment or system manufacturer.

1. Check connections for tightness and correct polarity. Replace damaged connections.
2. Turn on the system.
3. Check measured values and adjustable parameters (especially after replacing the BTL).

5.2 Operating notes

- Regularly check function of the BTL and all associated components.
- Take the BTL out of operation whenever there is a malfunction.
- Secure the system against unauthorized use.

6

P interface

6.1 Principle

The P interface is a universal impulse interface and unifies the functions of the falling and rising edges. The position measuring system control is done via Init and start/stop signals. Here, the “start pulse” is the reference point for the travel time measurement.

Reliable signal transmission, even with cable lengths of up to 500 m between the evaluation unit and BTL is ensured by the particularly fail-safe RS485 differential driver and receiver. Interfering signals are effectively suppressed.

DPI/IP is a protocol for direct data exchange between the controller and BTL. Here, the signal lines transmit additional information, such as manufacturer, sensor type, measuring length, and waveguide velocity. This makes it possible to start up or exchange a BTL without needing to manually change the control parameters.

The interface enables bi-directional communication and includes integrated diagnostic functions. Downtimes are reduced thanks to Plug & Play and automatic parameterization.

6.2 DPI/IP method

6.2.1 Function and characteristics

The DPI/IP method includes two operating modes, DPI measuring operation and operation with the IP data protocol.

DPI = digital pulse interface

IP = integrated protocol

DPI measuring operation

The Init pulse is sent to the BTL via the Init line at regular intervals, its rising edge triggers a measurement.

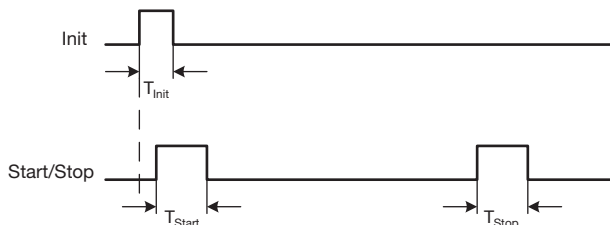

Fig. 6-1: Principle of data transfer in DPI measuring operation

T_{Init}	1 μ s to 5 μ s
T_{Start}	3 μ s to 5 μ s (typ. 4 μ s)
T_{Stop}	3 μ s to 5 μ s (typ. 4 μ s)

Operation with IP data protocol (BTL6-P111-...)

If the length of the Init pulse T_{IP} is extended to 10 μ s to 50 μ s, the BTL switches from DPI measuring mode to operation with the IP data protocol (see Fig. 6-2).

Here, a character string (command) is transferred to the BTL after the Init pulse. While the start pulse is still sent by the BTL as a response on the start/stop line, a character string (response) is transferred to the controller instead of the stop pulses, which contains the requested response dependent on the command.

Each character in the transfer protocol has the following bit structure:

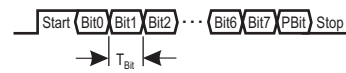

Start bit	Start-of-frame bit
Bit 0 to bit 7	8 data bits
PBit	Parity bit (even parity)
Stop	Stop-of-frame bit
T_{Bit}	4 μ s (bit length at a data rate of 250 kbit/s)

Data security during transfer of the string is achieved with the parity and CRC16 checks with polynomial $X^{16}+X^{12}+X^5+1$ (corresponds to 0x1021). If there is a transfer or protocol error, the BTL sends an appropriate error message as the response.

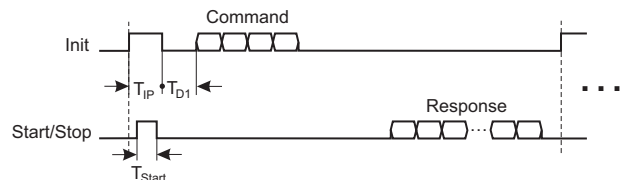

Fig. 6-2: Principle of data transfer with the IP data protocol

T_{IP}	10 μ s to 50 μ s Operation with IP data protocol
Command	Command to request BTL data (information that is stored in the BTL)
T_{Start}	3 μ s to 5 μ s (typ. 4 μ s)
T_{D1}	> 50 μ s
Response	Response in line with the request Alternative: error message

BTL6-P11 _-M _- _- _-A1-S115

Magnetostrictive Linear Position Sensor – Profile Style

6

P interface (continued)

6.2.2 Protocol parameters

Read out parameter						
	CI	LEN	CR	LEN	D0...Dn	n
Manufacturer ID	01h	00h	01h	07h	Vendor name ASCII coded 'B' 'A' 'L' 'L' 'U' 'F' 'F'	6
	or 06h	00h	06h	04h	Vendor code Hex coded 0x00000001 for Balluff	3
Ordering code	02h	00h	02h	17h	Type key ASCII coded Example: 'BTL6-P111-M0500-A1-S115'	22
Serial number	03h	00h	03h	0Bh	Serial number ASCII coded Example: '123456789DE'	10
	or 07h	00h	07h	04h	Serial number Hex coded Example: 0x0001F503 = 128259	3
Ultrasonic velocity	04h	00h	04h	03h	Ultrasonic velocity BCD coded Example: $v_{us} = 2832.56 \text{ m/s} = 28\text{h } 32\text{h } 56\text{h}$	2
	or 08h	00h	08h	04h	Ultrasonic velocity Hex coded Example: 0x00043EF5 = 2782.61 m/s	3
Null point offset	09h	00h	09h	04h	Zero point offset [μm] Example: 0x000088B8 = 35000 μm	3
Measuring length	0Ah	00h	0Ah	04h	Stroke length [mm] Example: 0x000001F4 = 500 mm	3
Error message			FFh	02h	Error code 01h = unknown command 02h = transmission error 03h = EEPROM access error	1

Tab. 6-1: List of request/response parameters

CI	Command ID
CR	Command response
LEN	Length of data D0...Dn
D0...Dn	Data frame
CRC	CRC16 from CI/CR to Dn

BTL6-P11 _-M _ _ _ -A1-S115

Magnetostrictive Linear Position Sensor – Profile Style

7

Technical data

7.1 Accuracy

The values are typical at 24 V DC, room temperature and a nominal length of 500 mm together with magnet BTL6-A-3800-2 or BTL6-A-3801-2.

The BTL is fully operational immediately, with full accuracy after warm-up.



For special versions, other technical data may apply. Special versions are indicated by the suffix -SA on the part label.

Resolution, position	≤ 10 μm
Non-linearity at	
nominal length ≤ 500 mm	± 200 μm
nominal length > 500 mm	±0.04 % FS (typ. ±0.02 % FS)
Hysteresis	≤ 10 μm
Repeat accuracy, typical	≤ 10 μm
Temperature coefficient ¹⁾	≤ 30 ppm/K
Detectable velocity	≤ 10 m/s

7.2 Ambient conditions

Ambient temperature	0 °C...+70 °C
Storage temperature	-40 °C...+100 °C
Relative humidity	< 90%, non-condensing
Shock rating	50 g/6 ms
Continuous shock per EN 60068-2-27 ²⁾	50 g/2 ms
Vibration per EN 60068-2-6 ²⁾	12 g, 10 ...2000 Hz
Degree of protection as per IEC 60529 with connector installed	IP67

7.3 Power supply

Stabilized voltage ³⁾	20...28 V DC
Ripple	≤ 0.5 V _{pp}
Current draw (at 24 V DC)	≤ 90 mA
Inrush current	≤ 3 A
Reverse polarity protection	Up to 36 V
Overvoltage protection	Up to 36 V
Dielectric strength (GND to housing)	500 V DC

7.4 Output

Start/stop difference	
Max. number of magnets ⁴⁾	4

7.5 Dimensions, weights

Housing diameter	30 mm
Nominal length	50...4012 mm
Weight (depends on length)	Approx. 1 kg/m
Housing material	Aluminum

¹⁾ Nominal length = 500 mm, magnet in the middle of the measuring range

²⁾ Individual specifications as per Balluff factory standard, resonant frequencies excluded

³⁾ For : The BTL must be externally connected via a limited-energy circuit as defined in UL 61010-1, a low-power source as defined in UL 60950-1 or a class 2 power supply as defined in UL 1310 or UL 1585.

⁴⁾ Number dependent on nominal length (see section 4.1)

BTL6-P11 _-M _ _ _ -A1-S115

Magnetostrictive Linear Position Sensor – Profile Style

8

Accessories

Accessories are not included in the scope of delivery and must be ordered separately.

8.1 Magnets

BTL6-A-3800-2

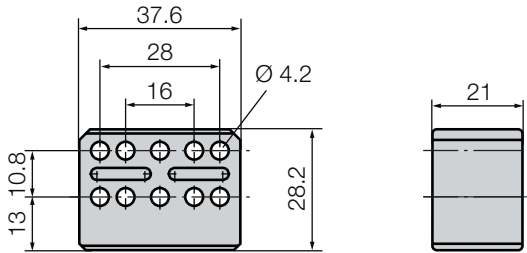

Fig. 8-1: Installation dimensions for BTL6-A-3800-2

Weight: Approx. 30 g
 Housing: Plastic
 Operating temperature: -40 °C...+85 °C

BTL6-A-3801-2

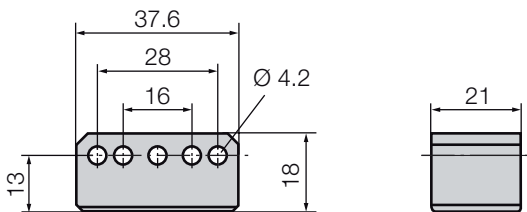

Fig. 8-2: Installation dimensions for BTL6-A-3801-2

Weight: Approx. 25 g
 Housing: Plastic
 Operating temperature: -40 °C...+85 °C

8.2 Mounting brackets/cuff

BTL6-A-MF01-A-43

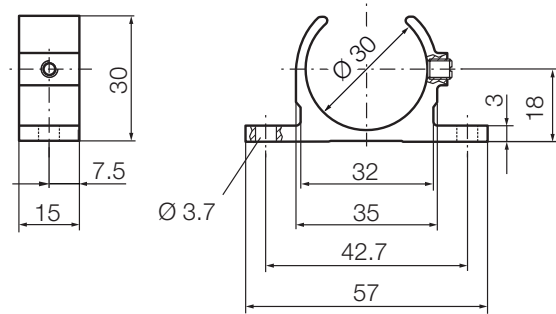

Fig. 8-3: Mounting bracket BTL6-A-MF01-A-43

Material: Aluminum

BTL6-A-MF01-A-50

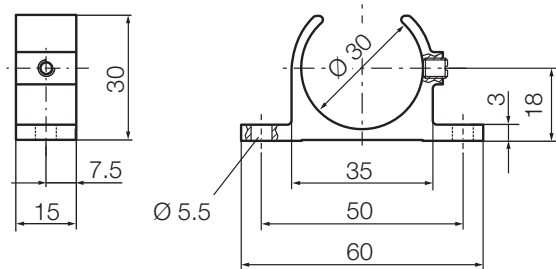

Fig. 8-4: Mounting bracket BTL6-A-MF01-A-50

Material: Aluminum

BTL6-A-MF03-K-50

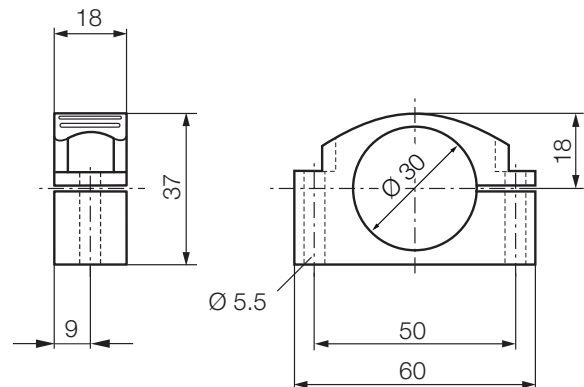

Fig. 8-5: Mounting cuff BTL6-A-MF03-K-50

Material: Plastic

8.3 Connectors

BKS-S115-PU- _ _

Straight connector, molded-on cable, preassembled
 M12, 8-pole
 Various cable lengths can be ordered, e.g.
 BKS-S115-PU-05: Cable length 5 m

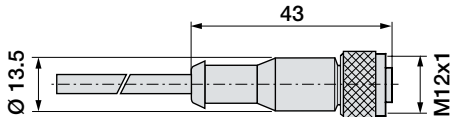

Fig. 8-6: Connector type BKS-S115-PU- _ _

BKS-S116-PU- _ _

Angled connector, molded-on cable, preassembled
 M12, 8-pole
 Various cable lengths can be ordered, e.g.
 BKS-S116-PU-05: Cable length 5 m

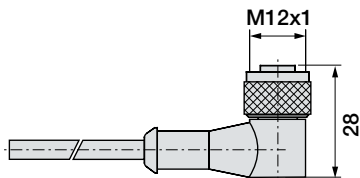

Fig. 8-7: Connector BKS-S116-PU- _ _

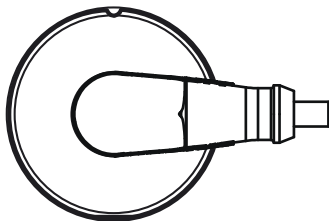

Fig. 8-8: Connector BKS-S116-PU- _ _ outlet

Pin	Color
1	YE yellow
2	GY gray
3	PK pink
4	RD red
5	GN green
6	BU blue
7	BN brown
8	WH white

Tab. 8-1: BKS-S115/116-PU- _ _ pin assignment

BTL6-P11 _-M _ _ _ -A1-S115
Magnetostrictive Linear Position Sensor – Profile Style

9

Type code

BTL6 - P111 - M0500 - A1 - S115

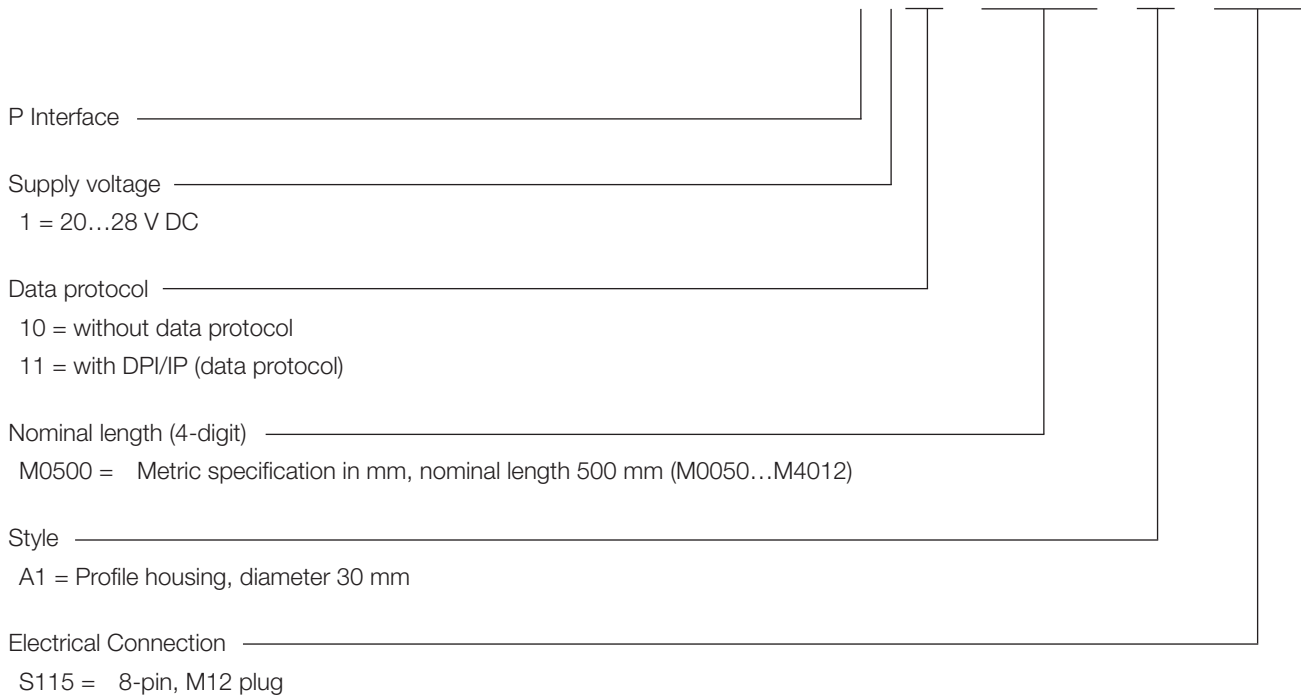

10 Appendix

10.1 Converting units of length

1 mm = 0.03937008 inches

mm	inch
1	0.03937008
2	0.07874016
3	0.11811024
4	0.15748031
5	0.19685039
6	0.23622047
7	0.27559055
8	0.31496063
9	0.35433071
10	0.393700787



Tab. 10-1: Conversion table mm to inches

1 inch = 25.4 mm

inch	mm
1	25.4
2	50.8
3	76.2
4	101.6
5	127
6	152.4
7	177.8
8	203.2
9	228.6
10	254

Tab. 10-2: Conversion table inches to mm

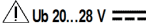
10.2 Part label

<p>BALLUFF</p> <p>BTL0000¹⁾</p> <p>BTL6-P111-M0500-A1-S115²⁾</p>	 ³⁾	<p>V_{us} = 2850,00 m/s</p> <p>174312345 DE³⁾</p>	<p>MICROPULSEAT</p> <p> Ub 20...28 V ===</p> <p>  US LISTED PROCESS CONTROL EQUIPMENT (TLW)</p> <p>www.balluff.com</p>
-------------------------------------------------------------------------------------------------------------	---------------------------------------------------------------------------------------------------	------------------------------------------------------------------------------------	------------------------------------------------------------------------------------------------------------------------------------------------------------------------------------------------------------------------------------------------------------------------------------------------------------------------------------------------------------------------------------------------------------

- ¹⁾ Order code
- ²⁾ Type
- ³⁾ Serial number

Fig. 10-1: Part label BTL6 (example)