

## BSI Q41K0-XB-MXS015-S92 BSI000J

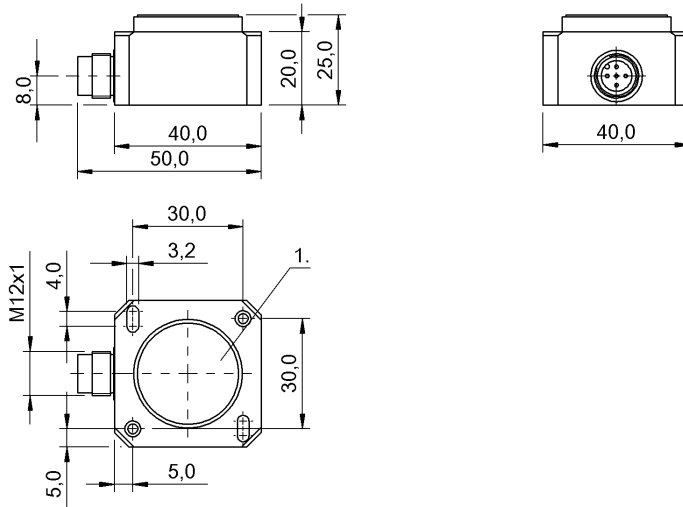

### Electrical connection

Connection	M12x1
Polarity reversal protected	yes
Short-circuit protection	yes

### Electrical data

Current draw max.	15 mA
Load resistance max., analog output	900 Ohm
MTTF (40 °C)	263 a
Operating voltage $U_b$	10...30 VDC
Pollution degree	3
Protected against miswiring	yes
Rated operating voltage $U_e$ DC	24 V
Ready delay $t_v$ max.	1 s

### Environmental conditions

Ambient temperature	-25...85 °C
EN 60068-2-27, Shock	yes
EN 60068-2-6, Vibration	yes
Protection class	III
Protection type IEC 60529	IP67
Relative humidity	95 %, non-condensing
Storage temperature	-40...85 °C

### General data

Approval/Conformity	CE cULus
---------------------	-------------

Basic standard	EN 61326-1
Measuring principle	MEMS

### Material

Housing material	Plastic
------------------	---------

### Mechanical data

Measuring axes	1
Rotation direction	Clockwise
Weight	45.00 g

### Output/Interface

Analog output	Analog, current, 4...20 mA
---------------	----------------------------

### Range/Distance

Accuracy	$\pm 0.6^\circ$
Resolution	$\leq 0.09^\circ$
Sampling rate	20 ms
Temperature drift max.	$\pm 0.8^\circ/10\text{ K}$

For further information on MTTF/B10d, please refer to the MTTF / B10d Certificate.

Specification of the MTTF value and the B10d value do not represent any binding quality and/or life expectancy guarantees.

BSI Q41K0-XB-MXS015-S92  
BSI000J

## Connector view

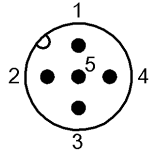

PIN 1: Vcc PIN 2: n.c. PIN 3: GND PIN 4: 4..20  
mA PIN 5: Centering

## Diagram

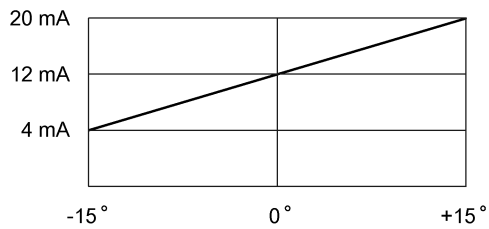

## Additional View

