



**Model Number**

**GLD3-RT/115/147**

Photoelectric slot sensor  
with 2 m fixed cable

**Features**

- Push-button programmable
- Adjustable sensitivity
- Detection of paper and foil labels, including translucent varieties

**Dimensions**

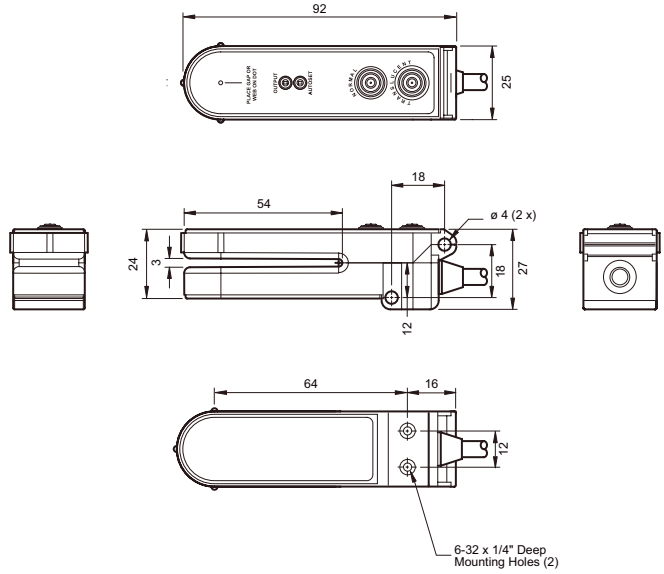

**Electrical connection**

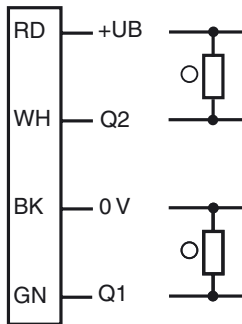

○ = Light on  
● = Dark on

Release date: 2012-12-07 09:59 Date of issue: 2012-12-07 911540\_eng.xml

Subject to modifications without notice

Pepperl+Fuchs Group  
www.pepperl-fuchs.com

USA: +1 330 486 0001  
fa-info@us.pepperl-fuchs.com

Germany: +49 621 776-4411  
fa-info@pepperl-fuchs.com

Copyright Pepperl+Fuchs  
Singapore: +65 6779 9091  
fa-info@sg.pepperl-fuchs.com

**Technical data****General specifications**

Light source	LED
Light type	modulated visible red light
Approvals	CE
USA	cULus
Canada	cULus
Fork width	3 mm

**Indicators/operating means**

Function display	2 LEDs
------------------	--------

**Electrical specifications**

Operating voltage	$U_B$	10 ... 30 V DC
Ripple		10 %
No-load supply current	$I_0$	≤ 45 mA

**Output**

Switching type	light/dark on	
Signal output	1 NPN and 1 PNP Short circuit and overload protected Reverse polarity protected	
Switching current	max. 150 mA	
Voltage drop	$U_d$	≤ 1.5 V
Switching frequency	f	5 kHz
Response time		≤ 100 μs

**Ambient conditions**

Ambient temperature	-40 ... 70 °C (-40 ... 158 °F)
Storage temperature	-40 ... 70 °C (-40 ... 158 °F)

**Mechanical specifications**

Protection degree	IP66
Connection	2 m fixed cable
Material	
Housing	Thermoplastic PPS
Optical face	zylex
Cable	PVC
Mass	82.21 g

**Compliance with standards and directives**

Standard conformity	
Product standard	EN 60947-5-2:2007 IEC 60947-5-2:2007

**Approvals and certificates**

UL approval	cULus
CCC approval	Products with a maximum operating voltage of ≤36 V do not bear a CCC marking because they do not require approval.

**GLD3 series programming****Programming standard labels:**

1. Use the external alignment guides on the sensor housing to position the alignment dot over the label gap
2. Push the teach button labeled "Normal" for 1 second
3. The green Autoset LED will blink several times very fast during the teach process  
If the teach is successful, the green Autoset LED will be ON.

If the teach is not successful, both the green Autoset LED and the red Output LED will blink 2 times very slow, then the green Autoset LED will be ON.

**Programming translucent labels:**

1. Use the external alignment guides on the sensor housing to position the alignment dot over the label gap
2. Push the teach button labeled "Translucent" for 1 second
3. The green Autoset LED will blink several times very fast during the teach process  
If the teach is successful, the green Autoset LED will be ON.

If the teach is not successful, both the green Autoset LED and the red Output LED will blink 2 times very slow, then the green Autoset LED will be ON.

**Light On/Dark On:**

The output of the sensor can be inverted by pressing both the Normal button and Translucent simultaneously. The red Output LED and the sensors output will change states.