

**Flow monitoring**  
**MK96 for flow sensors**  
**MK96-VP01**

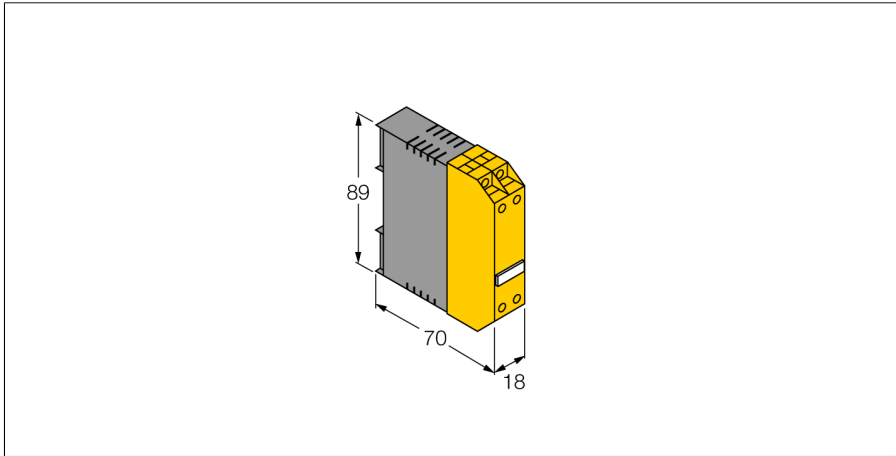

- For connection of a standard flow sensor
- Adjustment via potentiometer
- 6 LEDs for display of the flow state
- 2-wire DC, 19.2...28.8 VDC
- Antivalent PNP output

**Wiring Diagram**

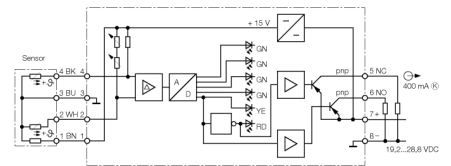

**Functional principle**

Signal processors not only supply insertion and inline sensors with voltage, they also process and display the measured signals. Devices with MK96..., MS96... and MC96... housing styles are available. The individual housing styles are designed for different operating voltages and feature various output and supplementary functions. For intrinsically safe flow sensors it is required to use signal processors with intrinsically safe control circuits of the series MS96...Ex... and MC96...Ex...

<b>Type designation</b>	MK96-VP01
Ident-No.	7525002
<b>Ambient temperature</b>	-20...+60 °C
<b>Operating voltage</b>	19.2...28.8 VDC
Current consumption	≤ 65 mA
Output function	PNP, NO/NC
Rated operational current	0.4 A
Voltage drop at I <sub>e</sub>	≤ 1.5 V
Short-circuit protection	yes
Reverse polarity protection	yes
Protection class	IP20
Protection class (terminals/housing)	IP20 / IP40
<b>Design</b>	Terminal chamber
Dimensions	70 x 18 x 89 mm
Housing material	Polycarbonate/ABS
Electrical connection	Terminal chamber
<b>Switching state</b>	LED chain, Green/Yellow/Red
Indication: Drop below setpoint	LED red
Indication: Setpoint reached	LED yellow
Indication: Setpoint exceeded	4 x LEDs green