

## Mounting References for Profile Sensors (EL, EP, ER)

Temposonics® EP and EL sensor models are mounted onto the machine with moveable mounting clamps. Mounting clamps slide into side grooves and should be distributed evenly along the sensor profile to best secure the sensor for each particular application.

For the E-Series model ER grooves for mounting clamps are available on three sides of the sensor housing, allowing versatile mounting orientations for the sensor's connector and extension cable. The rod is then attached to the moving machine part. Optional rod ends can be used to simplify sensor installation design and facilitate articulated motion sensing. Using dual rod ends the ER sensor can be mounted between two independent moving points, such as swinging door applications. Please note for model ER sensors having stroke lengths over 750 mm only the first 90% of the stroke length can be used for articulated type applications when the weight of the sensor is supported only by rod ends.

### NOTES

1. Temposonics® EL and EP sensors include two mounting clamps, (part no. 403 508) for sensor stroke lengths up to 1250 mm
2. One additional mounting clamp is included for stroke lengths over 1250 mm and for each additional 500 mm, thereafter.
3. MTS recommends using M5 screws (customer supplied) at a maximum fastening torque of 5 Nm when fastening mounting clamps.
4. ER: Mounting clamps are ordered separately. Two mounting clamps, (part number 403 508) are required for stroke lengths up to 750 mm. A least one additional mounting clamp is required for longer stroke lengths.

EP

Mounting clamp  
part no.: 403 508

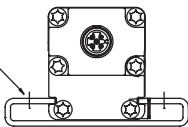

EL



Mounting clamp  
part no.: 403 508

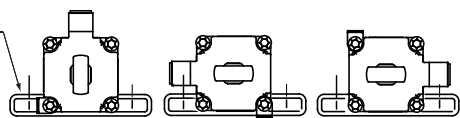

ER

Mounting clamp  
part no.: 403 508

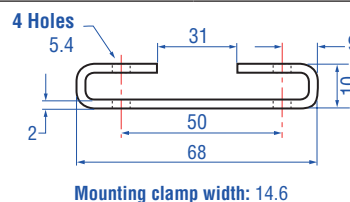

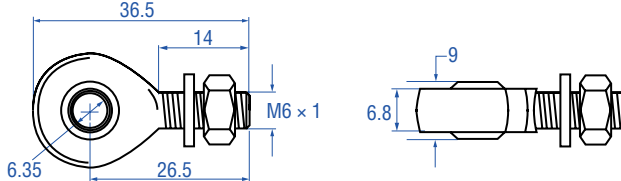
ID	Technical drawing	Description
<b>Mounting clamp</b> 403 508 		Sensor mounting for sensor models EL, EP and ER
<b>Rod end</b> 254 210 		Optional, male M6 threads for sensor model ER

All dimensions in mm