

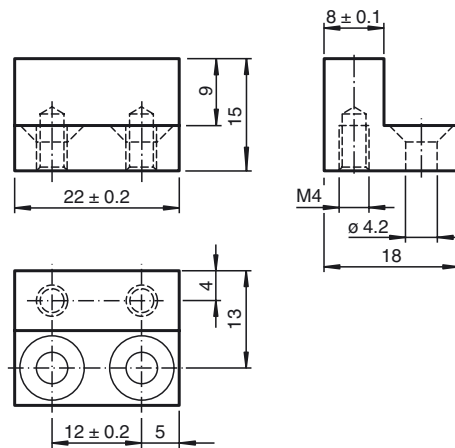

Dimensions



Model Number

BT-F90-G

Damping element for sensors of type F90, F112, and F166; front hole

Technical data

Mechanical specifications

Material	Steel ST37 / 1.0037
Mass	20 g

Release date: 2016-04-25 12:44 Date of issue: 2016-05-23 184702_eng.xml

Refer to "General Notes Relating to Pepperl+Fuchs Product Information".

Pepperl+Fuchs Group
www.pepperl-fuchs.com

USA: +1 330 486 0001
fa-info@us.pepperl-fuchs.com

Germany: +49 621 776 4411
fa-info@de.pepperl-fuchs.com

Singapore: +65 6779 9091
fa-info@sg.pepperl-fuchs.com